

M9537A AXIe Embedded Controller

2.8 GHz Quad-Core



Introduction

The Keysight Technologies M9537A is a second-generation AXIe embedded controller which enables new capabilities such as AXIe wide PCIe® support, multiple 4K video outputs, and optional high-speed disk cache. It is designed for high performance, compact AXIe systems.

The embedded controller is a powerful, one-slot module that easily integrates into hybrid test systems using the GP-IB, USB, and LAN front panel interfaces. Built upon a high-performance Intel Core i7 quad-core processor with Hyper-Threading Technology, it is perfect for high-performance applications and multi-tasking environments.

Key Features

- Intel i7-6820EQ 2.8 GHz quad-core processor with Hyper-Threading Technology
- Single-slot AXIe controller module
- Front removable 240 GB solid state drive
- 8 GB DDR4 RAM memory standard with an option for 16 GB
- Gen 3 x16 PCIe link to the AXIe backplane providing up to 16 GB/s max data bandwidth from CPU to AXIe backplane (actual data bandwidth depends on chassis capability)
- Front panel connection connections: four USB 3.0, two USB 2.0, two LAN (10/100/1000), three 4K-capable DisplayPort 1.2, and GP-IB.
- x8 Gen 3 PCIe IPASS connector on the front for controlling a second AXIe chassis or connection to RAID storage
- Available with either a Windows 7 or Windows 10 operating system (both are 64-bit)

High Performance Hardware Platform

Based on the high-performance Intel i7 processor with Hyper-Threading Technology, the M9537A embedded controller is ideal for multi-threading environments and multi-chassis systems.

Quad-Core Processor

The 6th-generation Intel i7-6820EQ quad-core processor offers superior CPU, graphics, enhanced security and media performance. Built into the M9537A embedded controller, it provides:

- Lower power consumption, higher performance per watt, faster loading times for demanding applications, with best multitasking performance
- Intel Hyper-Threading Technology offers a total of 8 simultaneous threads
- Direct media interface (DMI) 3.0 with 8 GT/s data bandwidth in each direction
- Improved GPU acceleration, with up to 40% better graphics performance with 4K video playback capability.
- Greater security, including Intel Software Guard Extensions (Intel SGX) and Intel Memory Protection Extensions (Intel MPX).

The provided Microsoft Windows 7 or 10 operating system takes full advantage of the processor's capabilities.

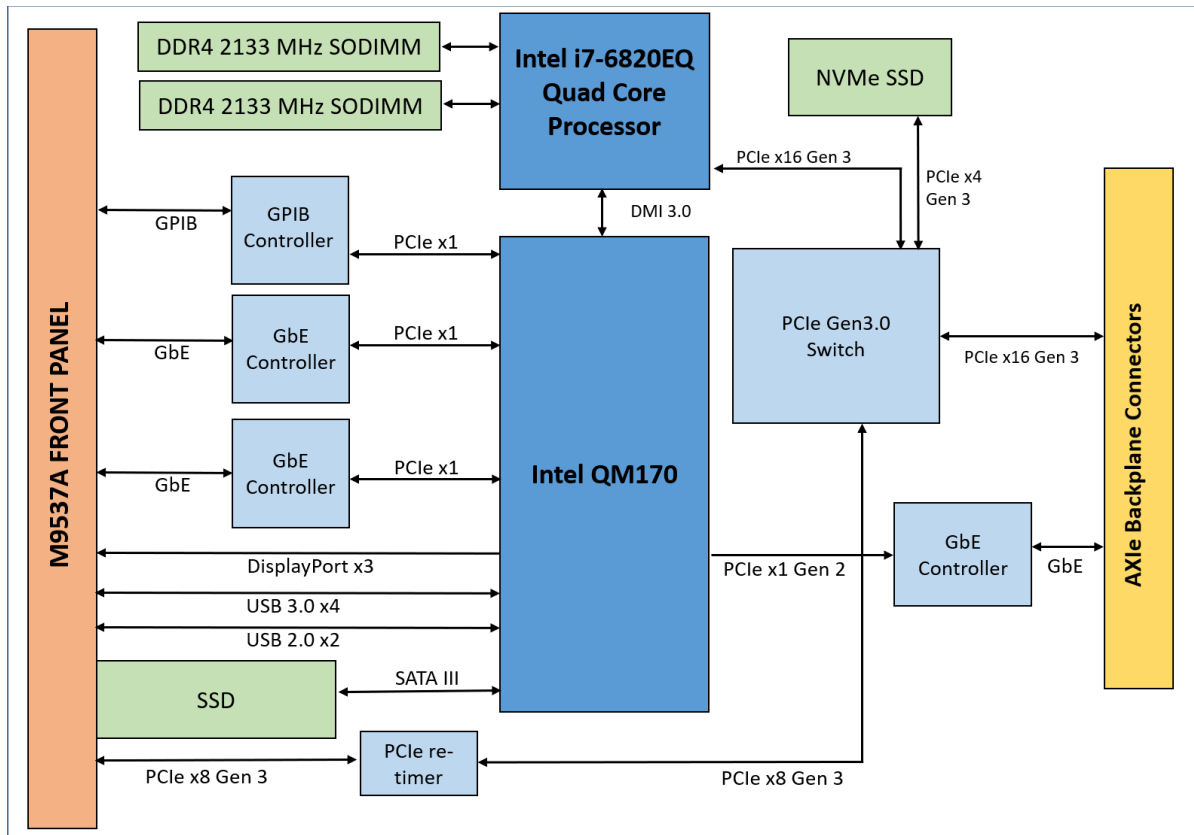

Figure 1. M9537A block diagram.

Memory

The M9537A embedded controller has two 260-pin SODIMM memory sockets which support DDR4-2133 RAM. Each socket can support 8 GB or 16 GB memory modules for a total memory capacity of 32 GB. The standard configuration utilizes a single 8 GB memory module.

Solid-State Drives

Secure environments benefit from the easily accessible, front removable 240 GB solid state drive (SSD) that is secured with front panel thumb screws. The SSD provides a faster boot time and is immune to vibration damage that mechanical drives may experience.

The optional NVM disk cache provides higher-speed data storage for measurement data. The NVMe™ drive utilizes a x4 PCIe Gen 3 interface resulting in a maximum sequential read/write speed of 2200 MBps/900 MBps. This is approximately 4x the performance of the SATA SSD.

Video

Built-in Intel HD graphics provides exceptional performance and supports up to three 4K monitors. For highest (4K) performance, use the optional Y1262A DisplayPort cable. For configuration flexibility, the optional Y1261A DisplayPort to DVI adapter is available. However, this adapter does not support 4K graphics.

Peripheral I/O

The M9537A embedded controller front panel connections include two USB 2.0 and four USB 3.0 connections, two Gigabit Ethernet ports, and GPIB. Additionally, a x8 PCIe connector is included for connecting to external RAID data storage or for AXIe system expansion.

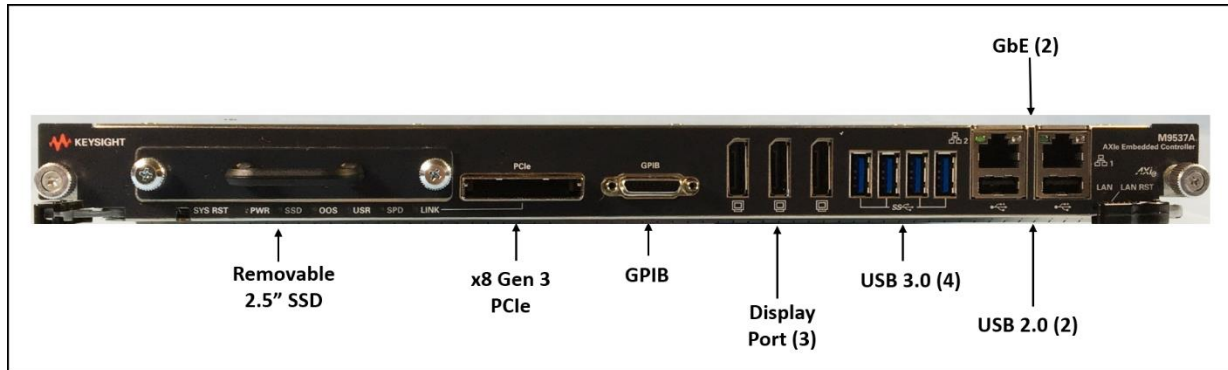

Figure 2. M9537A Front Panel

AXIe Compliance

The M9537A embedded controller is built to support the latest AXIe wide PCIe standard while providing backward compatibility with a chassis that is compliant to the original AXIe-1 standard. This means it can support an AXIe chassis with PCIe fabrics ranging from x4 Gen 2 to x16 Gen 3. In addition to the PCIe fabric, the embedded controller also provides an Ethernet channel for access to the AXIe Ethernet fabric.

The M9537A embedded controller does not provide the chassis management functions of an AXIe system module found in the embedded system module in the M9502A and M9505A or the M9521A used with the M9514A chassis. But once installed in the AXIe chassis, it has direct access to the AXIe backplane and can be used in place of an external host PC.

Multi-Chassis Configuration

The M9537A PXIe controller can control up to 4 AXIe and PXIe chassis using a cascade configuration. The x8 PCIe connector on the front panel can be used for cascading to a second AXIe chassis or to a PXIe chassis with an M902xA PXIe system module installed (Gen 3). Other configurations are possible. For additional information regarding multi-chassis configuration, go to www.keysight.com/find/pxie-multichassis

Easy Maintenance and Support

The M9537A embedded controller can easily be updated. The SSD can be installed or removed via the front panel without the need for tools. The SSD includes a recovery partition that can be used to restore the drive to factory default conditions. A spare SSD and carrier with all standard software components is also available (Y1266A or Y1266B). With the controller uninstalled from a chassis, SODIMM memory and the NVMe drive are easily accessed.

Technical Specifications and Characteristics

General Characteristics	
Standards compliance	
AXIe-1 Revision 3.0	
Chassis slot compatibility	
M9502A and M9505A	Insert M9537A in slot 1 (AXIe 1.0 secondary hub slot) ²
M9514A	Insert the M9537A in slots 1-6 and 8-14. The M9521A AXIe system module must be in slot 7.

Controller Characteristics	
CPU	Intel i7-6820EQ quad-core
CPU threads	8
CPU clock frequency	2.8 GHz
Chipset	Intel 5520/ICH10R
Backplane speed	PCIe revision 3.0 (Gen 3)
Video	
Type	Intel HD graphics 530 with 1.7 GB max video memory
Maximum resolution ³	DP: 3840 x 2160 @ 60 Hz (with Y1262A) DVI: 1920 x 1200 @ 60 Hz (with Y1261A)
Memory	
L2 Cache	8 MB
RAM Type	Two DDR4-2133 260-pin SODIMM Sockets
RAM Capacity	4 GB standard, 8 GB standard, 16 GB optional, 32 GB maximum
System storage	
Type	2.5" SATA III SSD
Size	240 GB
Optional high-speed disk cache	
Type	2.5" NVMe SSD
Interface	PCIe x4 Gen 3
Size	400 GB

² M9502A and M9505A require FW revision 1.3.42 or greater

³ DisplayPort adapters to other display standards are available in the market. Maximum resolution achieved is dependent on the adapter chosen.

Technical Specifications and Characteristics, cont.

Software

Operating system support

Windows Embedded 7 (64-bit)
Windows 10 IoT Enterprise LTSC (64-bit)

Pre-loaded software

Operating system and Keysight I/O libraries and AXIe chassis drivers

Mechanical Characteristics

Form factor	1-slot AXIe
Size	30.48 mm W x 322.25 mm H x 280 mm D
Weight	2.9 kg (6.4 lbs)

Electrical Characteristics

Current input	3.5A @ 48 V, nominal
Power dissipation	166 W

I/O Characteristics

Front Panel Connections

USB	Two USB 2.0 (type A) and four USB 3.0
Ethernet	Two 10/100/1000BASE-T (RJ45)
Video	Three DisplayPort 1.2
GPIO	Micro-D 25-pin
PCIe connector	x8 Gen 3 x8 iPass

AXIe Backplane

PCIe Link⁴

Base configuration	x4 Gen 2
Max configuration	x16 Gen 3
Maximum data bandwidth	Up to 16 GB/s (Gen 3) depending on chassis capability

Ethernet

Configuration	One 10/100/1000BASE-T channel
---------------	-------------------------------

⁴ Configuration selected based on chassis capability

Technical Specifications and Characteristics, cont.

Environmental Characteristics ^{5,6}		
Operating and Storage Conditions		
Temperature	Operating 0°C to 55°C	Storage -40°C to 70°C
Humidity	Type-tested at 95%, +40°C (non-condensing)	
Operating altitude	Up to 3048 m (10,000 ft)	
Storage altitude	Up to 4572 m (15,000 ft)	
Shock and vibration		
Operating random vibration: type-tested at 5 to 500 Hz, 0.21 g rms		
Survival random vibration: type-tested at 5 to 500 Hz, 2.09 g rms		
Regulatory Characteristics		
EMC		
IEC 61326-1		

⁵ Samples of this product have been type tested in accordance with the Keysight Environmental Test Manual and verified to be robust against the environmental stresses of storage, transportation and end-use; those stresses include but are not limited to temperature, humidity, shock, vibration, altitude, and power line conditions.

⁶ Test methods are aligned with IEC 60068-2 and levels are similar to MIL-PRF-28800F Class 3.

Definitions for specifications

Specification (spec)

Warranted performance. Specifications include guardbands to account for the expected statistical performance distribution, measurement uncertainties, and changes in performance due to environmental conditions. All specifications and characteristics apply over the operating environment outlined in the “Environmental and Regulatory” section of this data sheet. In addition, the following conditions must be met:

- Instrument is within its calibration cycle if calibration is required.
- Instrument has been stored for a minimum of 1 hour within the operating temperature range prior to turn-on and after a 30-minute warm-up period.

Characteristics

Characteristics describe product performance that is useful in the application of the product, but that is not covered by the product warranty. Characteristics are often referred to as Typical or Nominal values.

Typical (typ)

Expected performance of an average unit when operated over a 20 to 30 °C temperature range. Typical performance is not warranted. The instrument must be within its calibration cycle if calibration is required.

Nominal (nom)

Nominal describes representative performance that is useful in the application of the product when operated over a 20 to 30 °C temperature range. Nominal performance is not warranted.

Additional Information

All data are measured from multiple units at room temperature and are representative of product performance within the operating temperature range unless otherwise noted.

The data contained in this document is subject to change.

Ordering Information

Software

Supported Software Components	
Supported Operating systems (Pre-installed)	Microsoft Windows 7 or Windows 10 (both 64-bit only)
Instrument Drivers included	M9502A, M9505A, and M9514A
Keysight IO libraries (Pre-installed)	Includes VISA libraries, Keysight Connection Expert, IO monitor

Hardware

Model	Description
M9537A	AXIe high performance embedded controller
M9537A-M08	Memory, 8 GB RAM
M9537A-M16	Memory, 16 GB RAM
M9537A-WE6	Microsoft Windows Embedded Standard 7 operating system (64-bit)
M9537A-W16	Microsoft Windows 10 IoT Enterprise LTSC (64-bit)
Accessories	
Y1206A	Keyboard and optical mouse
Y1260A	GPIO cable
Y1261A	Display Port to DVI adapter
Y1262A	DisplayPort cable
Y1266A	Spare SSD with carrier: WES 7/64, 240 GB
Y1265B	Spare SSD with carrier Win 10/64 IoT, 240 GB
Related Products	
M9502A	AXIe chassis: 2-slot with integrated system module
M9505A	AXIe chassis: 5-slot with integrated system module
M9514A	AXIe chassis: 14-slot

Note: Microsoft will end the extended support of Windows Embedded Standard 7 on October 13, 2020 and won't provide technical support or software/security updates after this date. Keysight will continue to provide support for the M9037A after this date, but this does not include support of the Windows Embedded Standard 7 operating system. It is therefore recommended the M9037A is purchased with Windows 10 IoT Enterprise (option W16) to ensure extended support.

Learn more at: www.keysight.com

For more information on Keysight Technologies' products, applications or services, please contact your local Keysight office. The complete list is available at: www.keysight.com/find/contactus

