

**Agilent M9381A
PXIe Vector
Signal Generator**
1 MHz to 3 GHz or 6 GHz

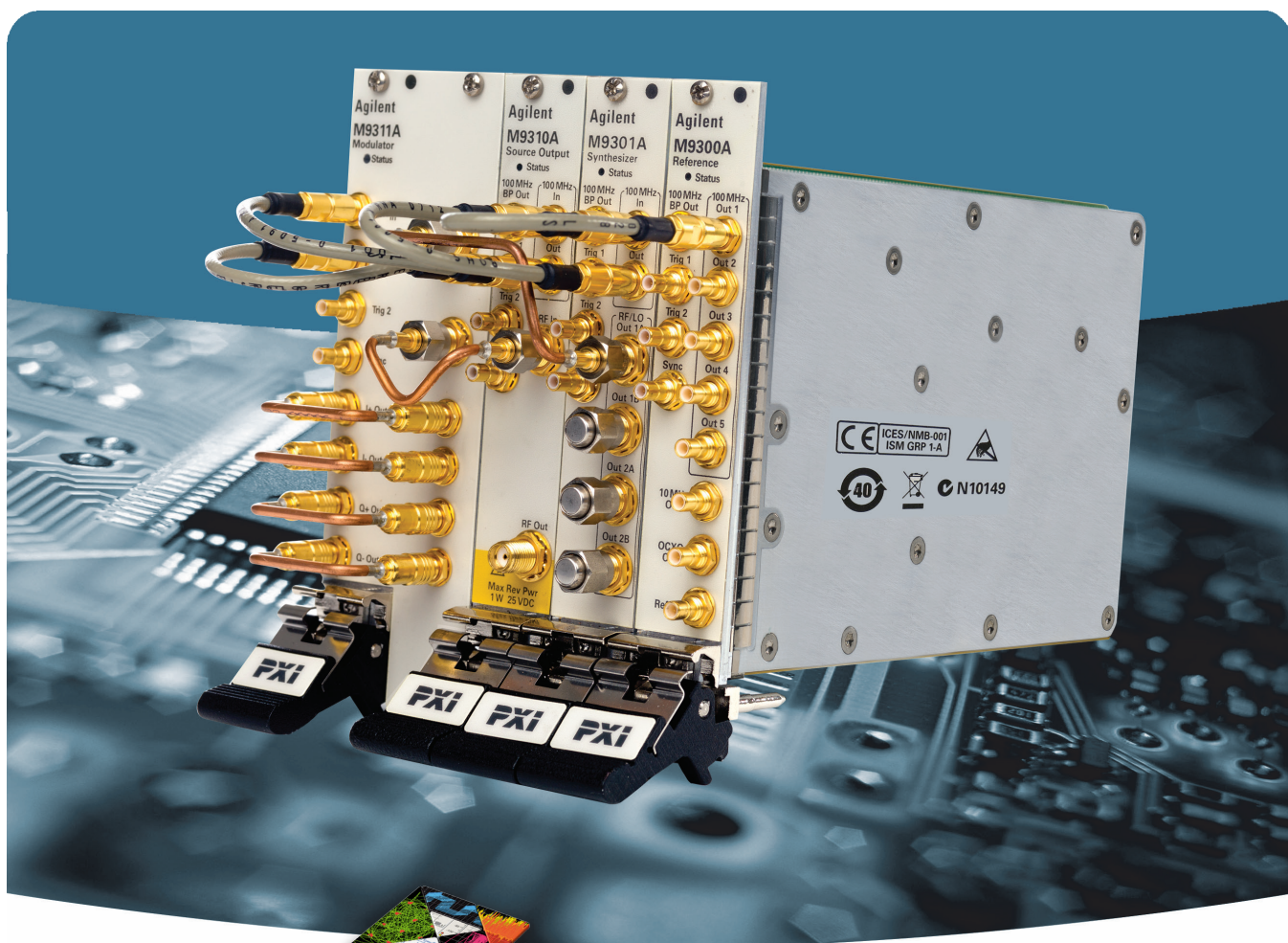

Data Sheet



*Challenge the Boundaries of Test
Agilent Modular Products*

Anticipate ___Accelerate ___Achieve



Agilent Technologies

OVERVIEW

Be ready for tomorrow - today

RF requirements keep growing while timelines keep shrinking. To help ease the technical and business pressures, the right test solution provides continuity in measurements and longevity in capability. The Agilent M9381A PXIe Vector Signal Generator is the next logical step in RF signal generation.

The M9381A PXI VSG, combined with the M9391A PXIe Vector Signal Analyzer - the PXI VSA/G - provides a complete solution for fast, high quality measurements optimized for RF manufacturing test environments.

To help you get proven results even faster, Agilent's PXI VSA/G can be used with its Signal Studio and Waveform Creator software as well as the X-Series measurement applications for modular instruments, 89600 VSA software and SystemVue. These software applications enable you to investigate, validate and test your RF communications designs.

From fully modular hardware to software leverage to worldwide support, the PXI VSA/G is the low-risk way to manage change and be ready for tomorrow—today.

Product description

The M9381A PXIe vector signal generator (PXI VSG) is a compact modular solution that provides frequency coverage from 1 MHz to 3 or 6 GHz. A typical M9381A configuration includes four individual PXIe modules—M9311A digital vector modulator, M9310A source output, M9301A synthesizer, and the M9300A frequency reference—designed for fast data interfaces and high-speed automated test systems. Instrument control is provided through a soft front panel and programmatic interfaces tuned to your application development environment of choice.

The M9381A PXI VSG is MIMO ready, enabling design validation engineers to ensure that their WLAN and LTE designs perform well under a variety of conditions. MIMO receiver testing is supported by Agilent's multi-format Signal Studio software, with full support for 802.11ac and LTE standards based generation.

For more information on product configurations, see the M9381A & M9391A configuration guide, literature number 5991-0897EN. For more information on the M9391A PXI VSA, see the M9391A data sheet, literature number 5991-2603EN.

Applications

- Cellular picocell and femtocell test
- Handset component test
- Military component test
- Public safety and homeland security radio test
- Wireless device test
- Wireless transceiver design validation
- WLAN and LTE MIMO R&D, design validation and production test

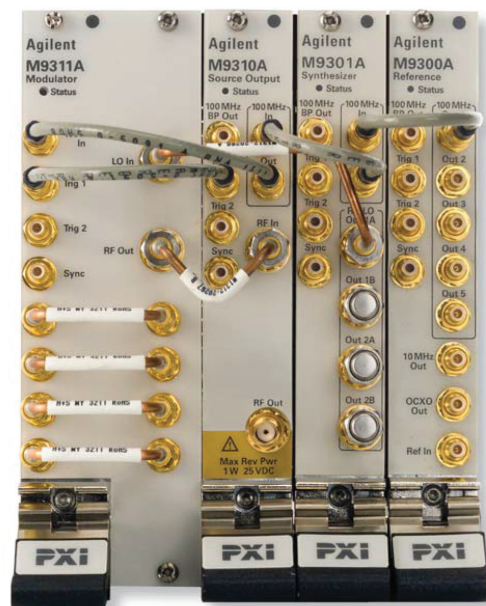

Figure 1. M9381A PXIe vector signal generator with four modules consisting of the M9311A digital vector modulator, M9310A source output, M9301A synthesizer, and the M9300A frequency reference.

fastune
Technology Innovation

Agilent **fastune** is an electrical power and radio frequency (RF) switching functionality that uses digital baseband power level changes and frequency offsets, while maintaining amplitude and phase calibrated accuracy, in order to provide the speed and accuracy needed to reduce the cost of test in modern communication manufacturing.



OVERVIEW

Product features

- Frequency coverage from 1 MHz to 3 GHz or 6 GHz.
- 10 μ s switching speed with *fasttune*.
 - Set the RF frequency to the center of the band being tested and then program the baseband frequency offset to any value within the modulation bandwidth (e.g., ± 80 MHz with 160 MHz bandwidth).
 - Set the RF power level to the maximum required for all tests and then set baseband power offset from 0 to 20 dB below RF level.
- Fast RF switching speed:
 - 240 μ s for frequency and amplitude changes.
 - 105 μ s for amplitude-only changes.
- Output power of +18 dBm across the frequency range.
- Better than ± 0.4 dB absolute amplitude accuracy.
- RF modulation bandwidth up to 160 MHz, with $< \pm 0.3$ dB RF I/Q channel flatness.
- AM, FM, phase, pulse, and multitone modulation.
- Arbitrary waveform memory up to 1024 MSa.
- Supported Signal Studio software: W-CDMA/HSPA+, cdma2000[®]/1xEV-DO, GSM/EDGE/Evo, LTE/LTE-Advanced FDD, LTE/LTE-Advanced TDD, TD-SCDMA/HSDPA, WLAN 802.11a/b/g/n/ac, Bluetooth[®], Broadcast radio, Digital video, Mobile WiMax[™], and GNSS.
- License key upgrades for all performance options: frequency range, output power, fast switching, generation bandwidth, and memory.
- Chassis slot compatibility: PXIe slot.

Uncompromising values

- Accelerates test throughput with the industry's fastest RF frequency and amplitude switching speeds and 3201 list mode points.
- Reduces test time with *fasttune* that allows you to switch amplitude and frequency in < 10 μ s.
- Ready to test wideband components with optional 160 MHz RF bandwidth.
- Keeps costs manageable—purchase what you need today and easily upgrade later using license-key upgrades without returning your modules to Agilent.
- Reduces development time and simplifies integration into existing test environments with multiple drivers and programmatic interfaces.
- Reduces startup time with Agilent IO libraries for easy configuration, one-step software install, and integrated instrument level VSG soft front panel.
- Fast repair turnaround time with calibrated core exchange.

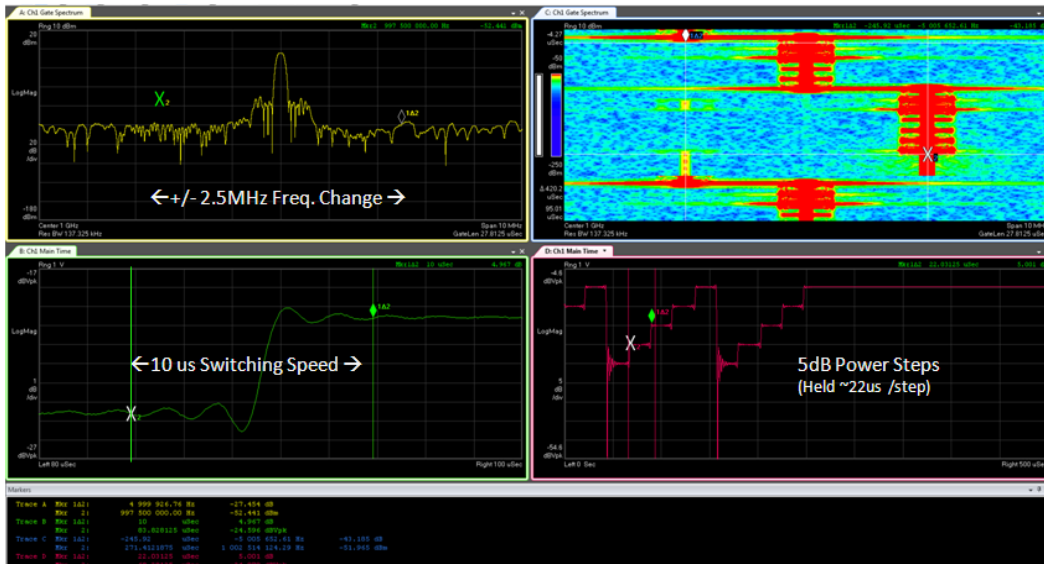

Figure 2. M9381A baseband power and frequency offset tuning in < 10 μ s as shown by the 89600 VSA software.

TECHNICAL SPECIFICATIONS AND CHARACTERISTICS

Block diagram

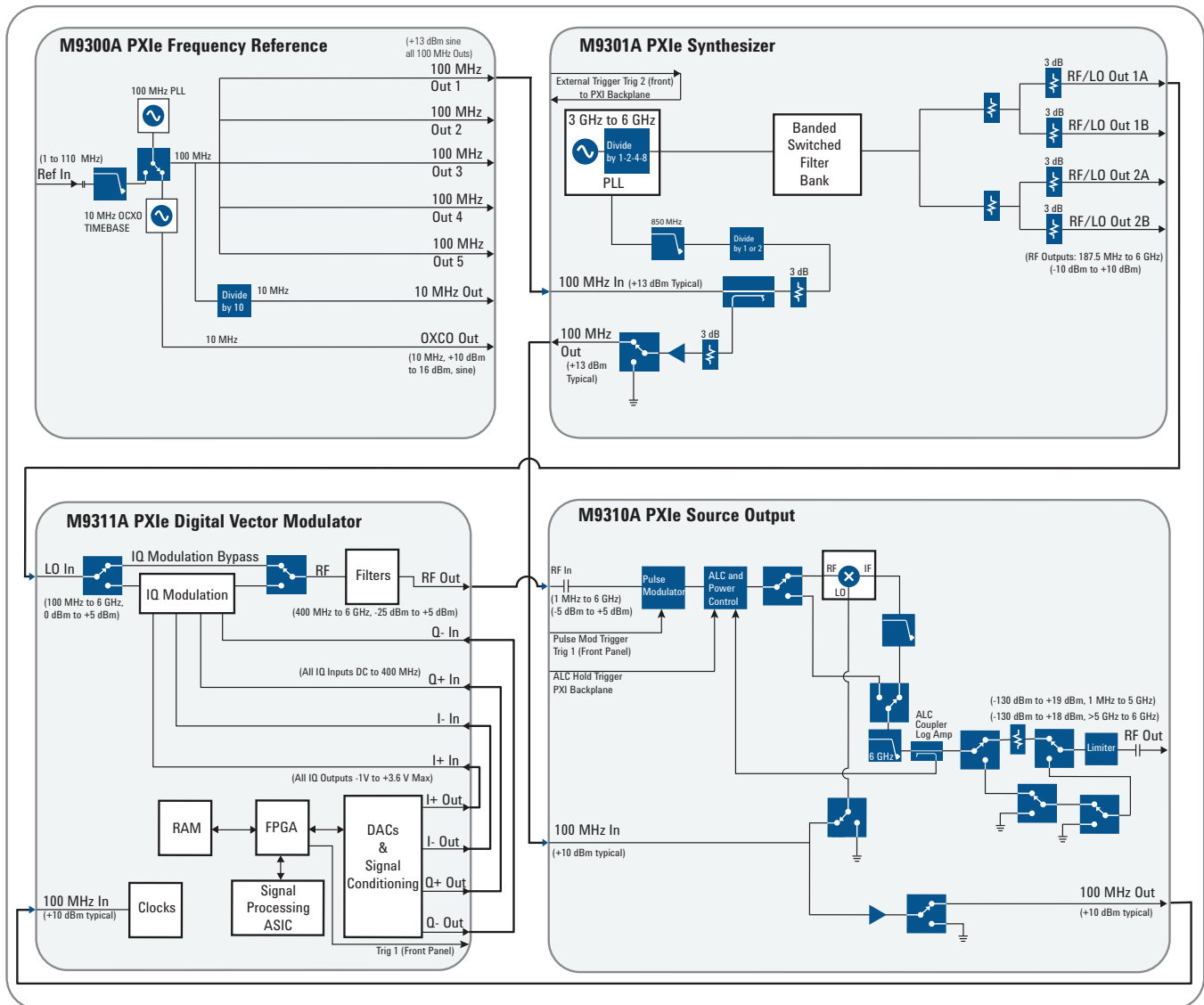

Figure 5. M9381A PXIe vector signal generator block diagram with four modules consisting of the M9301A synthesizer, M9310A source output, M9311A digital vector modulator, and the optional M9300A frequency reference.

TECHNICAL SPECIFICATIONS AND CHARACTERISTICS

Definitions for specifications

Temperatures referred to in this document are defined as follows:

- Full temperature range = Individual module temperature of ≤ 75 °C as reported by the module, and environment temperature of 0 to 55 °C.
- Controlled temperature range = Individual module temperature of ≤ 55 °C as reported by the module, and environment temperature of 20 to 30 °C.

Specifications describe the warranted performance of calibrated instruments. Data represented in this document are specifications unless otherwise noted under the following conditions.

- Calibrated instruments have been stored for a minimum of 2 hours within the full temperature range
- 45 minute warm-up time
- Calibration cycle maintained
- When used with Agilent M9300A frequency reference and Agilent interconnect cables

Characteristics describe product performance that is useful in the application of the product, but that is not covered by the product warranty. Characteristics are often referred to as *Typical* or *Nominal* values and are italicized.

- **Typical** describes characteristic performance, which 80% of instruments will meet when operated within the controlled temperature range.
- **Nominal** describes representative performance that is useful in the application of the product when operated within the controlled temperature range.

Recommended best practices in use

- Use slot blockers and EMC filler panels in empty module slots to ensure proper operating temperatures. Agilent chassis and slot blockers optimize module temperature performance and reliability of test.
- At environment temperatures above 45 °C, chassis fan should be set to high.

Additional information

- All graphs contain measured data from one unit and is representative of product performance within the controlled temperature range unless otherwise noted.
- The specifications contained in this document are subject to change.
- Specifications use the normal PLL mode setting, unless otherwise stated. Narrow loop bandwidth refers to specifications using the best wide offset PLL mode setting `AGM938X_VAL_SYNTHESIZER_PLL_MODE_BEST_WIDE_OFFSET`, available in the M938x Vector Signal Generator/CW Source Instrument Drivers versions 1.2.300 and later.

TECHNICAL SPECIFICATIONS AND CHARACTERISTICS

FREQUENCY

Frequency range	
Option F03	1 MHz to 3 GHz
Option F06	1 MHz to 6 GHz
Resolution	0.01 Hz

Frequency switching speed	Standard, nominal	Option UNZ, nominal	
List mode switching speed ¹		Normal loop bandwidth	Narrow loop bandwidth
Baseband frequency offset change ²	$\leq 5\text{ ms}$	$\leq 10\ \mu\text{s}$	$\leq 10\ \mu\text{s}$
ALC off ³			
Arbitrary frequency change	$\leq 5\text{ ms}$	$\leq 185\ \mu\text{s}$	$\leq 240\ \mu\text{s}$
Frequency change < 100 MHz within a band ⁴	$\leq 5\text{ ms}$	$\leq 115\ \mu\text{s}$	$\leq 120\ \mu\text{s}$
ALC on ³			
Arbitrary frequency change	$\leq 5\text{ ms}$	$\leq 365\ \mu\text{s}$	$\leq 365\ \mu\text{s}$
Frequency change < 100 MHz within a band ⁴	$\leq 5\text{ ms}$	$\leq 265\ \mu\text{s}$	$\leq 265\ \mu\text{s}$
Non-list mode switching speed ⁵			
Baseband frequency offset change ²	$\leq 5\text{ ms}$	$\leq 250\ \mu\text{s}$	$\leq 250\ \mu\text{s}$
Arbitrary frequency change	$\leq 5\text{ ms}$	$\leq 2\text{ ms}$	$\leq 2.1\text{ ms}$

List mode	
List mode channel parameters	80 parameters including RF frequency, power, modulation arb and baseband, ALC, power search, triggers
Dwell time	0 to 429 seconds
Number of points	1 to 3201
Triggering	Immediate, external, software, timer

Frequency reference (M9300A PXIe frequency reference module)	
Reference outputs	
100 MHz Out (Out 1 through Out 5)	
Amplitude	$\geq 10\text{ dBm}$ <i>13 dBm, typical</i>
Connectors	5 SMB snap-on
Impedance	<i>50 Ω, nominal</i>

1. Time from trigger input to frequency and amplitude settled within limits given below with digital modulation on and channel corrections enabled. Specifications are for amplitudes lower than +17 dBm and using an M9036A embedded controller in an M9018A chassis.
2. Baseband offset frequency settled within 100 Hz. Baseband offset can be adjusted \pm from carrier frequency within limits determined by RF modulation bandwidth. Synthesizer frequency and amplitude are not changing and ALC off.
3. Carrier frequency settled within 1 ppm or 1 kHz, whichever is greater, and amplitude settled within 0.2 dB (within the controlled temperature range) or within 0.5 dB (at the full temperature range). For frequency changes $\geq 1.6\text{ GHz}$ at carriers $\geq 3.2\text{ GHz}$ nominal frequency settling time within $\pm 0.5\%$ of final frequency is 125 μs . Simultaneous carrier frequency and amplitude switching.
4. Frequency bands: One (1 to 400 MHz); Two (> 400 to < 750 MHz); Three (≥ 750 to < 1500 MHz); Four (≥ 1500 to < 3000 MHz); Five (≥ 3000 to 6000 MHz).
5. Mean time from IVI command to carrier frequency settled within 1 ppm or 1 kHz whichever is greater and amplitude settled within 0.2 dB. Simultaneous carrier frequency and amplitude switching.

TECHNICAL SPECIFICATIONS AND CHARACTERISTICS

Frequency reference (continued)	
Reference outputs (continued)	
10 MHz Out	
Amplitude	9.5 dBm, nominal
Connectors	1 SMB snap-on
Impedance	50 Ω , nominal
OCXO Out	
Amplitude	11.5 dBm, nominal
Connectors	1 SMB snap-on
Impedance	50 Ω , nominal
Frequency accuracy	
Same as accuracy of internal time base or external reference input	
Internal timebase	
Accuracy	\pm [(time since last adjustment x aging rate) \pm temperature effects \pm calibration accuracy]
Frequency stability	
Aging rate	
Daily	< ± 0.5 ppb/day, after 72 hour warm-up
Yearly	< ± 0.1 ppm/year, after 72 hours warm-up
Total 10 years	< ± 0.6 ppm/10yrs, after 72 hours warm-up
Achievable initial calibration accuracy (at time of shipment)	$\pm 5 \times 10^{-8}$
Temperature effects	
20 to 30 °C	< ± 10 ppb
Full temperature range	< ± 50 ppb
Warm up	
5 minutes over +20 to +30 °C, with respect to 1 hour	< ± 0.1 ppm
15 minutes over +20 to +30 °C, with respect to 1 hour	< ± 0.01 ppm
External reference input	
Frequency	1 to 110 MHz, sine wave
Lock range	± 1 ppm, nominal
Amplitude	0 to 10 dBm, nominal
Connector	1 SMB snap-on
Impedance	50 Ω , nominal

TECHNICAL SPECIFICATIONS AND CHARACTERISTICS

AMPLITUDE

Output parameters		
Settable range	Standard	Option 1EA
	+10.7 to -130 dBm	+20 to -130 dBm
Resolution		
ALC on ⁶	0.02 dB, nominal	
I/Q mode, ALC off ⁷	0.02 dB, nominal	
I/Q mode, ALC off, baseband offset change	0.001 dB, nominal	
CW mode, ALC off	0.3 dB, nominal	

Maximum output power		
Frequency	Standard	Option 1EA
1 MHz to 5 GHz	+10 dBm	+19 dBm
> 5 to 6 GHz	+10 dBm	+18 dBm

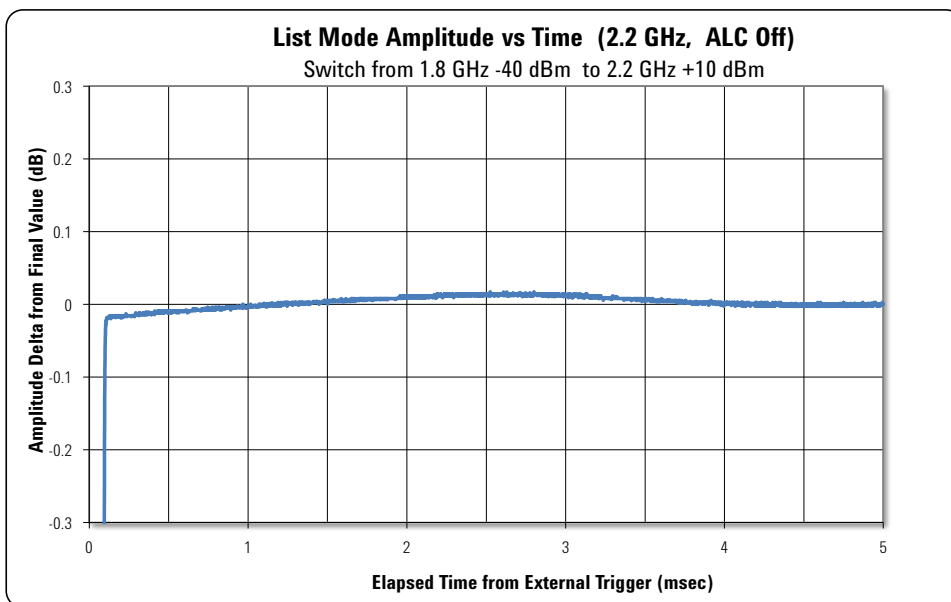

Figure 6. List mode amplitude vs time showing fast settling time to specified level accuracy.

6. Settable to 0.01 dB.
7. After a power search.

TECHNICAL SPECIFICATIONS AND CHARACTERISTICS

Amplitude switching speed	Standard, nominal	Option UNZ, nominal
List mode switching speed ⁸		
Baseband power level change ⁹	$\leq 5 \text{ ms}$	$\leq 10 \mu\text{s}$
ALC off	$\leq 5 \text{ ms}$	$\leq 105 \mu\text{s}$
ALC on	$\leq 5 \text{ ms}$	$\leq 105 \mu\text{s}$
Non-list mode switching speed ¹⁰		
Baseband power level change ⁹	$\leq 5 \text{ ms}$	$\leq 250 \mu\text{s}$
Arbitrary power level change	$\leq 5 \text{ ms}$	$\leq 1.5 \text{ ms}$

List mode

See frequency specification section for more detail

Absolute level accuracy in CW mode [ALC on] ¹¹

Frequency	< Max power to -20 dBm	< -20 to -110 dBm	< -110 to -120 dBm	< -120 to -130 dBm
1 MHz to 3 GHz	$\pm 0.4 \text{ dB}$ <i>$\pm 0.15 \text{ dB}$, typical</i>	$\pm 0.5 \text{ dB}$ <i>$\pm 0.15 \text{ dB}$, typical</i>	$\pm 0.7 \text{ dB}$ <i>$\pm 0.25 \text{ dB}$, typical</i>	$\pm 0.8 \text{ dB}$, nominal
> 3 to 6 GHz	$\pm 0.5 \text{ dB}$ <i>$\pm 0.15 \text{ dB}$, typical</i>	$\pm 0.6 \text{ dB}$ <i>$\pm 0.25 \text{ dB}$, typical</i>	$\pm 1.0 \text{ dB}$ <i>$\pm 0.5 \text{ dB}$, typical</i>	$\pm 0.8 \text{ dB}$, nominal

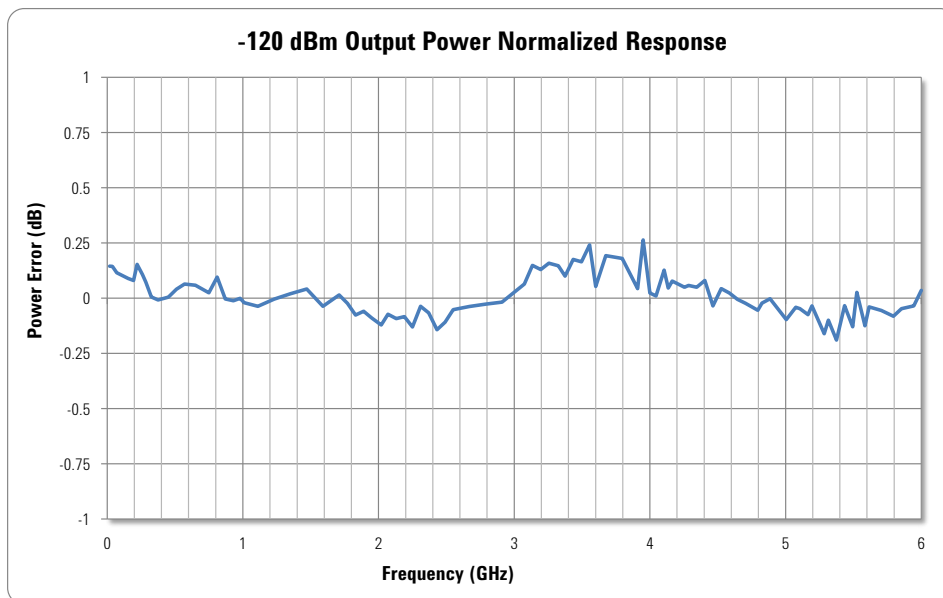

Figure 7. Output power normalized response at -120 dBm.

8. Time from trigger input to amplitude settled within 0.2 dB (within the controlled temperature range) or within 0.5 dB (at the full temperature range). Carrier frequency is not changing. Measurements made with the M9036A embedded controller in an M9018A chassis.
9. Baseband offset amplitude settled within 0.2 dB. Baseband offset can be adjusted from 0 to -20 dB.
10. Mean time from IVI command to amplitude settled within 0.2 dB. Carrier frequency is not changing.
11. Specifications apply within the controlled temperature range. For temperatures outside this range, absolute level accuracy degrades by $\pm 0.02 \text{ dB}/^\circ\text{C}$.

TECHNICAL SPECIFICATIONS AND CHARACTERISTICS

Absolute level accuracy (ALC off, relative to ALC on)¹²

Frequency

1 MHz to 5 GHz ± 0.25 dB, typical

> 5 to 6 GHz ± 0.62 dB, typical

Power search¹³

Time < 20 ms, nominal

Absolute level accuracy in digital I/Q mode (ALC on, relative to CW)¹⁴

≤ 15 dBm ± 0.7 dB (± 0.25 dB, nominal)

≤ 10 dBm ± 0.2 dB

≤ 0 dBm ± 0.1 dB

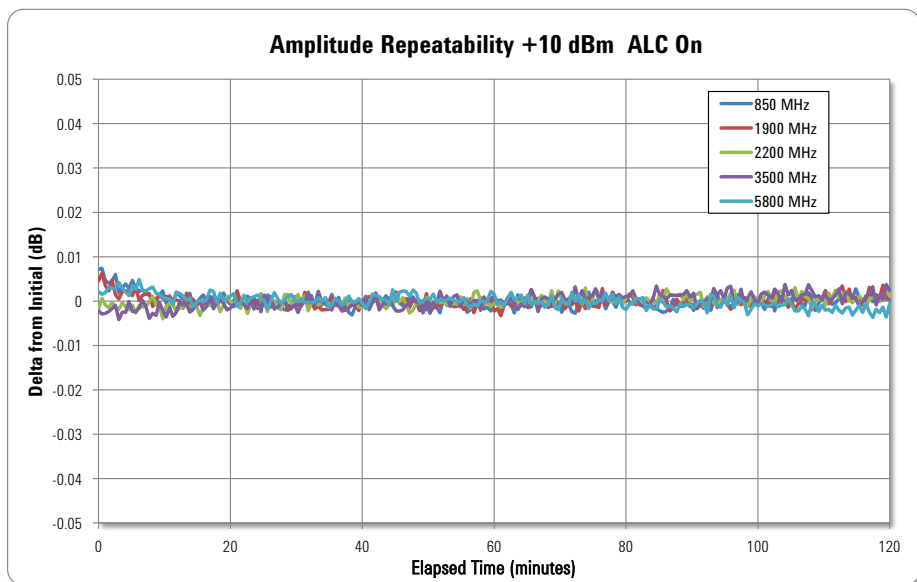

Figure 8. Amplitude repeatability at various carrier frequencies. Repeatability measures the ability of the instrument to return to a given power setting after a random excursion to any other frequency and power setting. It should not be confused with absolute level accuracy.

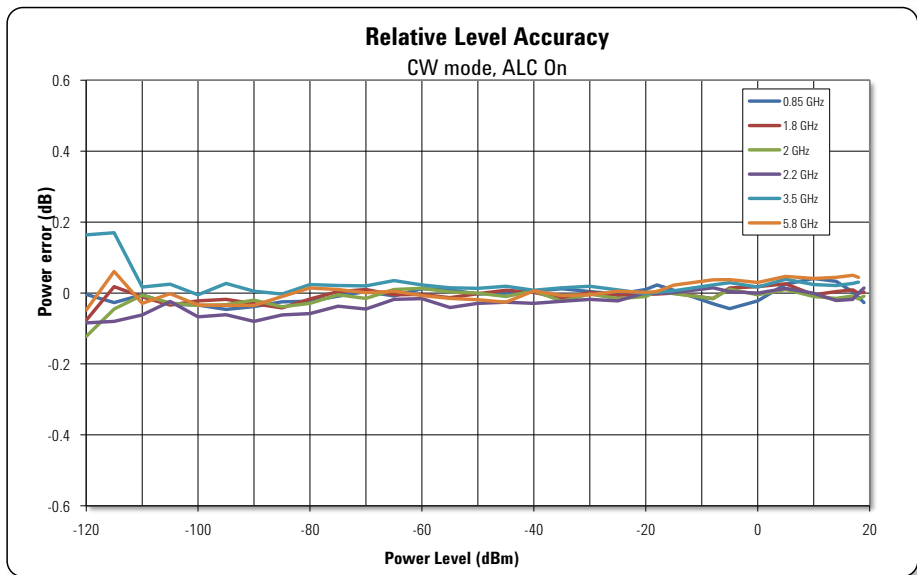

Figure 9. Relative level accuracy at various carrier frequencies.

12. After a power search, with a single side-band signal and with power search blanking on.

13. Power search is an internal alignment routine that improves level accuracy with ALC off.

14. QPSK waveform 4 MSa/s symbol rate. Specifications apply within the controlled temperature range.

TECHNICAL SPECIFICATIONS AND CHARACTERISTICS

VSWR	
1 MHz to 6 GHz	< 1.5:1, nominal
Maximum reverse power	
1 MHz to 6 GHz	1 W, nominal
Max DC voltage	25 VDC, nominal

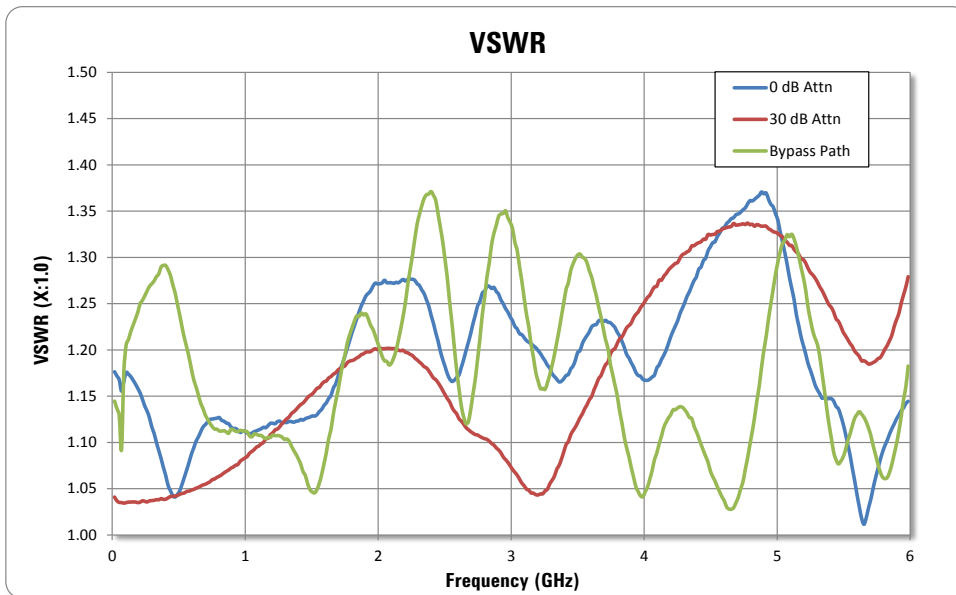

Figure 10. Measured VSWR from 1 MHz to 6 GHz.

TECHNICAL SPECIFICATIONS AND CHARACTERISTICS

SPECTRAL PURITY

Phase noise at 20 kHz offset	Normal loop bandwidth
1 GHz	-122 dBc/Hz, typical
2 GHz	-117 dBc/Hz, typical
3 GHz	-112 dBc/Hz, typical
6 GHz	-108 dBc/Hz, typical

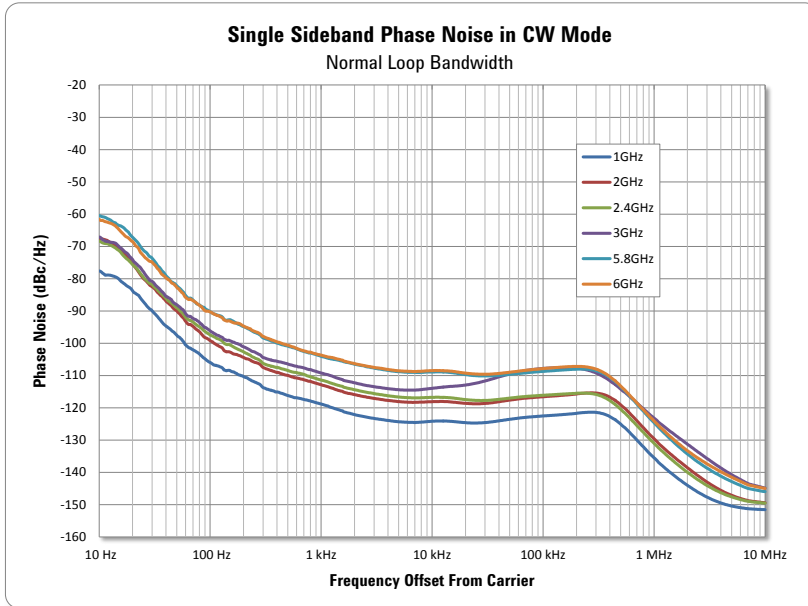

Figure 11. Single sideband phase noise in normal loop bandwidth, CW mode from 10 Hz to 10 MHz, offset at 1, 2, 2.4, 3, 5.8, and 6 GHz.

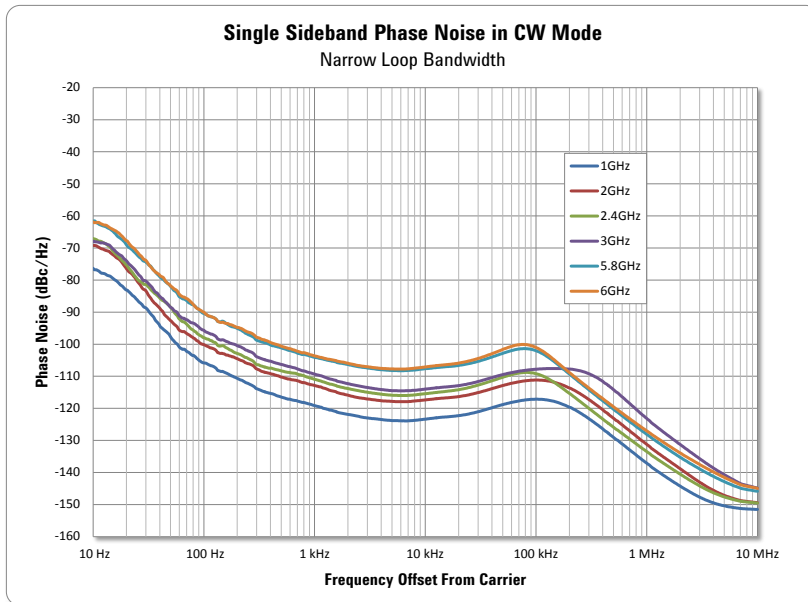

Figure 12. Single sideband phase noise in narrow loop bandwidth, CW mode from 10 Hz to 10 MHz, offset at 1, 2, 2.4, 3, 5.8, and 6 GHz.

TECHNICAL SPECIFICATIONS AND CHARACTERISTICS

Broadband noise floor				
Range				
1 MHz to 6 GHz	< -140 dBc/Hz, nominal, at +10 dBm output power level			
Harmonics				
Range	≤ 0 dBm	≤ 0 dBm	≤ +10 dBm	≤ +10 dBm
1 MHz to < 1 GHz	< -39 dBc	-43 dBc, typical	< -35 dBc	-37 dBc, typical
1 to 2.5 GHz	< -34 dBc	-38 dBc, typical	< -32 dBc	-34 dBc, typical
> 2.5 GHz	< -35 dBc	-38 dBc, typical	< -30 dBc	-32 dBc, typical
Nonharmonics ¹⁵				
Nonharmonic miscellaneous spurious ¹⁶	< -70 dBc, nominal			
Nonharmonic HET band mixing spurs (0 dBm)	< -67 dBc, nominal			
Nonharmonic Frac-N	< -66 dBc, nominal			
Subharmonics				
1 MHz to 6 GHz	none			

15. Non-harmonics include mixing spurs for frequencies below 400 MHz, synthesizer spurs, and other miscellaneous chassis and power supply products, for offsets > 10 kHz.

16. With Agilent M9036A embedded controller.

TECHNICAL SPECIFICATIONS AND CHARACTERISTICS

ANALOG MODULATION

Pulse parameters	
Pulse on/off ratio 1 to 400 MHz	> 85 dB, typical
Pulse on/off ratio > 400 MHz to 6 GHz	> 95 dB, typical
Pulse on/off ratio with I/Q modulation	> 140 dB, nominal
Pulse rise/fall time	< 10 ns, nominal

Frequency modulation (Option UNT) ¹⁷	
Maximum deviation	1.25 MHz
Resolution of deviation	0.1 Hz
Maximum rate	5 MHz

Phase modulation (Option UNT) ¹⁷	
Maximum deviation	10 radians
Resolution of deviation	0.001 radians
Maximum rate	5 MHz

Amplitude modulation (Option UNT) ¹⁷	
Maximum depth	100%
Resolution of depth	0.001%
Maximum rate	6.25 MHz

Pulse (Option UNT) ¹⁷	
Rate	1 Hz to 1 MHz
Pulse on time	200 ns to 2 ms

Multitone (Option UNT) ¹⁷	
Rate (tone separation)	100 Hz to 1 MHz
Number of tones	2 to 16

17. With arbitrary waveforms. Sine, dual-sine, triangle, ramp, and square waveforms supported.

TECHNICAL SPECIFICATIONS AND CHARACTERISTICS

VECTOR MODULATION

Residual carrier leakage ¹⁸		
Frequency	Specifications	Typical
1 MHz to 5 GHz	< -55 dBc	< -62 dBc
> 5 to 6 GHz	< -51 dBc	< -58 dBc

I/Q image suppression ¹⁸		
Frequency	Specifications	Typical
1 to 850 MHz	< -43 dBc	< -54 dBc
> 850 MHz to 5 GHz	< -52 dBc	< -61 dBc
> 5 to 6 GHz	< -45 dBc	< -54 dBc

I/Q baseband feed-through ¹⁸	
Frequency	Specifications
1 to 400 MHz	< -65 dBc, typical
> 400 MHz to 3 GHz	< -80 dBc, typical
> 3 GHz	< -90 dBc, typical

RF modulation bandwidth with internal ARB	
Option B04 (standard)	40 MHz
Option B10	100 MHz
Option B16	160 MHz

RF I/Q channel flatness		
Bandwidth	1 MHz to 5.5 GHz	> 5.5 to 6 GHz
40 MHz BW (Option B04 standard)	< ±0.1 dB, typical	< ±0.2 dB, typical
100 MHz BW (Option B10)	< ±0.2 dB, typical	< ±0.3 dB, typical
160 MHz BW (Option B16)	< ±0.3 dB, typical	< ±0.5 dB, typical

Multi-channel ¹⁹	
Maximum channel-to-channel deviation	20 ns, nominal

18. Measured with an SSB waveform with an I/Q scale factor of 0.25 for offsets ≤ 50 MHz, after executing IQ alignment. Specifications apply at 625 kHz and 50 MHz offsets.

19. MIMO capability only supported when configured with an Agilent M9018A PXIe chassis.

TECHNICAL SPECIFICATIONS AND CHARACTERISTICS

Corrected phase error		
Bandwidth	1 GHz	3 GHz
40 MHz BW (Option B04 standard)	$\pm 0.25^\circ$, nominal	$\pm 1.25^\circ$, nominal
100 MHz BW (Option B10)	$\pm 0.65^\circ$, nominal	$\pm 2.5^\circ$, nominal
160 MHz BW (Option B16)	$\pm 0.9^\circ$, nominal	$\pm 3.0^\circ$, nominal

Arbitrary waveform memory maximum playback capacity	
Option M01 (standard)	32 MSa
Option M05	512 MSa
Option M10	1024 MSa

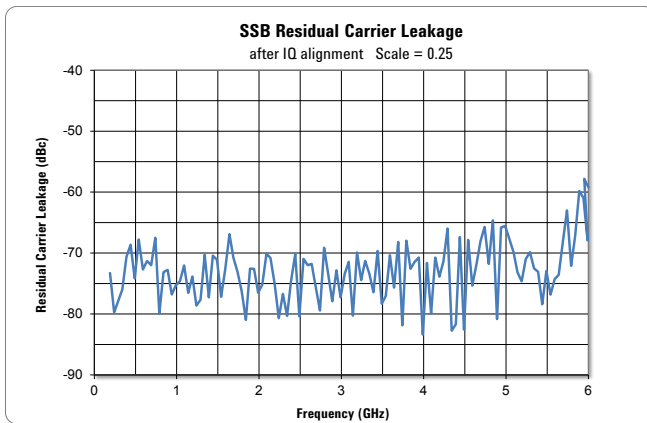

Figure 13. SSB residual carrier leakage.

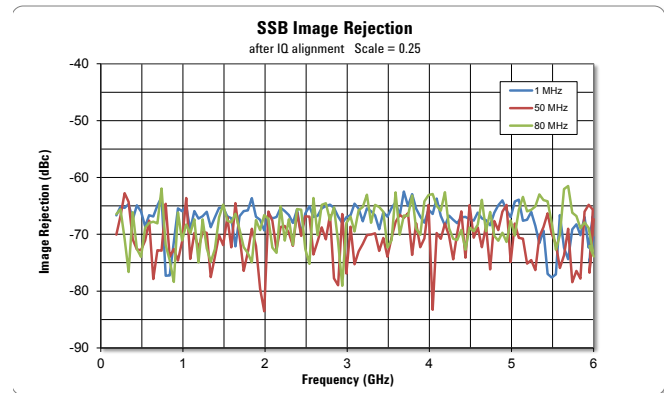

Figure 14. SSB image rejection at 1, 50, and 80 MHz offsets.

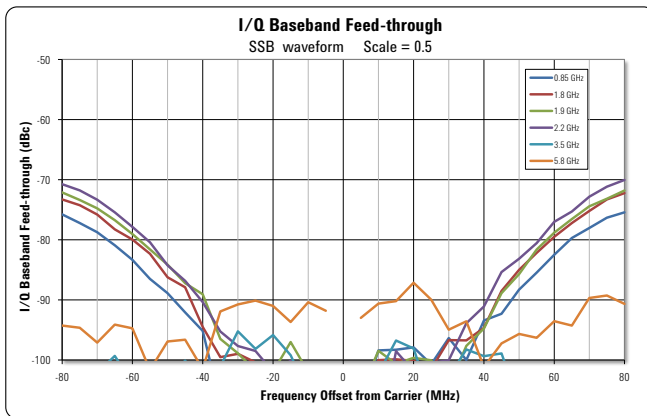

Figure 15. I/Q baseband feed-through at various carrier frequencies.

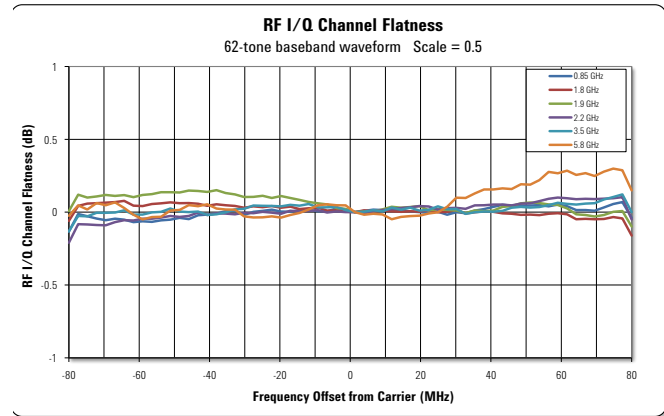

Figure 16. RF I/Q channel flatness at various carrier frequencies.

TECHNICAL SPECIFICATIONS AND CHARACTERISTICS

3GPP W-CDMA performance data ²⁰							
Modulation type		QPSK					
EVM (2 GHz, 1 DPCH, ≤ 5 dBm)		0.57% rms, typical					
Channel distortion ²¹			ACLR				
Offset	Configuration	Frequency	Spec (dBc)	0 dBm		5 dBm	
				Typical (dBc)	Spec (dBc)	Typical (dBc)	Spec (dBc)
Adjacent 5 MHz	1 DPCH 1 carrier	900 MHz	-70	-72	-71	-72	
Alternate 10 MHz			-71	-73	-72	-74	
Adjacent 5 MHz		1800 to 2200 MHz	-70	-72	-70	-71	
Alternate 10 MHz			-71	-73	-72	-73	
Adjacent 5 MHz	64 DPCH 1 carrier	900 MHz	-69	-71	-69	-72	
Alternate 10 MHz			-71	-72	-71	-73	
Adjacent 5 MHz		1800 to 2200 MHz	-68	-70	-68	-70	
Alternate 10 MHz			-70	-72	-71	-73	

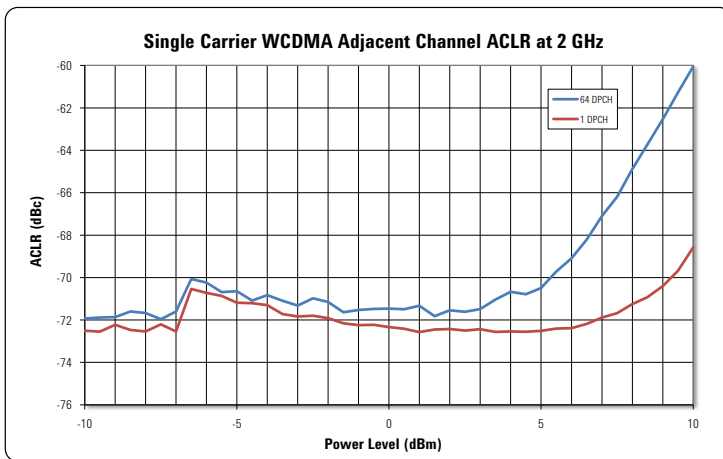

Figure 17. Single carrier W-CDMA adjacent channel ACLR versus power level at 2 GHz.

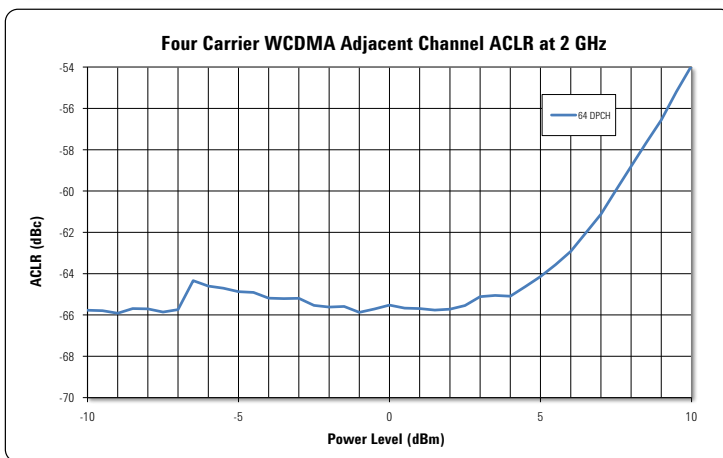

Figure 18. Four carrier W-CDMA adjacent channel ACLR versus power level at 2 GHz.

20. W-CDMA characteristics apply at 900 MHz and between 1.8 to 2.2 GHz, 3.84 Mcps rate, within 5 °C of IQ alignment.

21. Specifications apply within the controlled temperature range.

TECHNICAL SPECIFICATIONS AND CHARACTERISTICS

GSM/EDGE performance data ²²						
	GSM		EDGE			
Modulation type	GMSK bursted		3pi/8-8PSK bursted			
Modulation rate	270.833 ksps		70.833 ksps			
EVM [ALC off]	$\pm 0.15^\circ$ rms global phase error, typical		0.3%, typical			
EVM [ALC on]	$\pm 0.15^\circ$ rms, global phase error, typical		0.6%, typical			
Output RF spectrum (ORFS)	Narrow loop bandwidth		Narrow loop bandwidth			
Offset	GSM, typical		EDGE, typical			
200 kHz	-37 dBc		-39 dBc			
400 kHz	-66 dBc		-66 dBc			
600 kHz	-71 dBc		-71 dBc			
800 kHz	-76 dBc		-76 dBc			
1200 kHz	-81 dBc		-81 dBc			
1800 kHz	-80 dBc		-79 dBc			
WLAN 802.11 performance data			EVM			
Preamble only - narrow loop bandwidth						
Power level	-7 dBm		0 dBm		+5 dBm	
	Typical	Nominal	Typical	Nominal	Typical	Nominal
802.11n, 20 MHz, 64 QAM						
2.4 GHz	-52.5 dB	-53.2 dB	-52.7 dB	-53.4 dB	-51.3 dB	-52.1 dB
5.8 GHz	-44.6 dB	-45.8 dB	-45.2 dB	-45.8 dB	-41.3 dB	-42.8 dB
802.11n, 40 MHz, 64 QAM						
2.4 GHz	-48.5 dB	-49.5 dB	-48.6 dB	-49.7 dB	-47.8 dB	-49.2 dB
5.8 GHz	-44.1 dB	-44.5 dB	-44.1 dB	-44.7 dB	-40.1 dB	-41.7 dB
802.11ac, 80 MHz, 256 QAM						
5.8 GHz	-42.2 dB	-45.6 dB	-42.8 dB	-46.1 dB	-40.6 dB	-42.8 dB
802.11ac, 160 MHz, 256 QAM						
5.8 GHz	-42.5 dB	-43.7 dB	-42.7 dB	-44.1 dB	-39.8 dB	-40.6 dB
Preamble, pilots & data - narrow loop bandwidth						
Power level	-7 dBm		0 dBm		+5 dBm	
	Nominal		Nominal		Nominal	
802.11n, 20 MHz, 64 QAM						
2.4 GHz	-54.4 dB		-54.7 dB		-54.5 dB	
5.8 GHz	-46.5 dB		-46.9 dB		-43.7 dB	
802.11n, 40 MHz, 64 QAM						
2.4 GHz	-52.8 dB		-53.3 dB		-52.9 dB	
5.8 GHz	-47.2 dB		-47.6 dB		-44.0 dB	
802.11ac, 80 MHz, 256 QAM						
5.8 GHz	-48.7 dB		-48.9 dB		-45.2 dB	
802.11ac, 160 MHz, 256 QAM						
5.8 GHz	-47.2 dB		-47.8 dB		-43.9 dB	

22. GSM/EDGE characteristics apply 800 to 900 MHz, and 1800 to 1900 MHz, with 1 timeslot channel configuration, within $\pm 5^\circ\text{C}$ of IQ alignment.

TECHNICAL SPECIFICATIONS AND CHARACTERISTICS

WLAN 802.11 performance data		EVM, nominal		
Preamble only - narrow loop bandwidth				
Power level	0 dBm			
	2-channel, nominal	3-channel, nominal	4-channel, nominal	
802.11n, 20 MHz, 64 QAM	2.4 GHz	-52.4 dB	-50.8 dB	-50.9 dB
	5.8 GHz	-45.6 dB	-44.3 dB	-45.1 dB
802.11n, 40 MHz, 64 QAM	2.4 GHz	-49.2 dB	-48.3 dB	-48.8 dB
	5.8 GHz	-44.2 dB	-42.7 dB	-43.3 dB
802.11ac, 80 MHz, 256 QAM	5.8 GHz	-43.3 dB	-42.0 dB	-42.9 dB
802.11ac, 160 MHz, 256 QAM	5.8 GHz	-42.1 dB	-40.3 dB	-41.7 dB
Preamble, pilots & data - narrow loop bandwidth				
Power level	0 dBm			
	2-channel, nominal	3-channel, nominal	4-channel, nominal	
802.11n, 20 MHz, 64 QAM	2.4 GHz	-54.2 dB	-54.2 dB	-52.9 dB
	5.8 GHz	-46.4 dB	-45.6 dB	-45.7 dB
802.11n, 40 MHz, 64 QAM	2.4 GHz	-52.8 dB	-52.7 dB	-51.7 dB
	5.8 GHz	-47.1 dB	-46.1 dB	-45.3 dB
802.11ac, 80 MHz, 256 QAM	5.8 GHz	-46.8 dB	-45.4 dB	-44.7 dB
802.11ac, 160 MHz, 256 QAM	5.8 GHz	-45.4 dB	-43.0 dB	-43.3 dB

TECHNICAL SPECIFICATIONS AND CHARACTERISTICS

LTE FDD performance data			
Modulation type	64 QAM		
EVM	1-channel ²³	2-channel - MIMO ²⁴	4-channel - MIMO ²⁴
900 MHz	-52.0 dB (0.25%), nominal	-50.5 dB (0.30%), nominal	-51.5 dB (0.27%), nominal
2 GHz	-50.0 dB (0.32%), nominal	-50.0 dB (0.32%), nominal	-50.5 dB (0.30%), nominal
ACPR ²³	Adjacent (< 5 dBm)	Alternate (< 5 dBm)	
900 MHz	-68 dBc, nominal	-70 dBc, nominal	
2 GHz	-67 dBc, nominal	-70 dBc, nominal	

System requirements		
Topic	Windows 7 and Vista requirements	Windows XP requirements
Operating systems	Windows 7 (32-bit and 64-bit) Windows Vista, SP1 and SP2 (32-bit and 64-bit)	Windows XP, Service Pack 3
Processor speed	1 GHz 32-bit (x86), 1 GHz 64-bit (x64) (no support for Itanium 64)	600 MHz or higher required 800 MHz recommended
Available memory	4 GB minimum 8 GB or greater recommended	3 GB minimum
Available disk space ²⁵	1.5 GB available hard disk space, includes: <ul style="list-style-type: none"> • 1 GB available for Microsoft .NET framework 3.5 SP1 ²⁶ • 100 MB for Agilent IO libraries suite 	
Video	Support for DirectX 9 graphics with 128 MB graphics memory recommended (Super VGA graphics is supported)	Super VGA (800 x 600) 256 colors or more
Browser	Microsoft Internet Explorer 7 or greater	Microsoft Internet Explorer 6 or greater
M938x vector signal generator/CW source instrument drivers		
Agilent IO libraries	Version 16.3.16603.3 or later	
Narrow loop bandwidth	Narrow loop bandwidth using the best wide offset PLL mode setting AGM938X_VAL_SYNTHESIZER_PLL_MODE_BEST_WIDE_OFFSET requires instrument drivers version 1.2.300.0 or later	

23. LTE FDD E-TM 1.1 and E-TM 3.1, 10 MHz, 64 QAM PDSCH, full resource block, ≤+6 dBm. Characteristics apply with ±5 °C of IQ alignment.

24. LTE FDD MIMO R9 downlink, full filled 64 QAM 10 MHz (50 RB), at 0 dBm, open-loop spatial multiplexing transmission mode.

25. Because of the installation procedure, less disk space may be required for operation than is required for installation.

26. .NET framework runtime components are installed by default with Windows Vista and Windows 7. Therefore, you may not need this amount of available disk space.

TECHNICAL SPECIFICATIONS AND CHARACTERISTICS

Environmental and physical specifications				
Temperature	Operating Non-operating (storage)	0 to 55 °C -40 to +70 °C		
Humidity ²⁷		Type tested at 95%, +40 °C (non-condensing)		
Shock/vibration ²⁷	Operating random vibration Survival random vibration Functional shock Bench handling	Type tested at 5 to 500 Hz, 0.21 g rms Type tested at 5 to 500 Hz, 2.09 g rms Type tested at half-sine, 30 g, 11 ms Type tested per MIL-PRF-28800F		
Altitude		Up to 15,000 feet (4,572 meters)		
Connectors	RF OUT	SMA female		
EMC		Complies with European EMC Directive 2004/108/EC • IEC/EN 61326-2-1 • CISPR Pub 11 Group 1, class A • AS/NZS CISPR 11 • ICES/NMB-001 This ISM device complies with Canadian ICES-001. Cet appareil ISM est conforme a la norme NMB-001 du Canada.		
Warm-up time		45 minutes		
Size	M9300A M9301A M9310A M9311A	1 PXIe slot 1 PXIe slot 1 PXIe slot 2 PXIe slots		
Dimensions	Module	Length	Width	Height
	M9300A	210 mm	22 mm	130 mm
	M9301A	210 mm	22 mm	130 mm
	M9310A	210 mm	22 mm	130 mm
	M9311A	210 mm	42 mm	130 mm
Weight	M9300A M9301A M9310A M9311A	0.551 kg (1.215 lbs) 0.535 kg (1.179 lbs) 0.551 kg (1.215 lbs) 0.901 kg (1.986 lbs)		
Power drawn from chassis	M9300A M9301A M9310A M9311A	≤ 18 W ≤ 25 W ≤ 28 W ≤ 45 W		

27. Samples of this product have been type tested in accordance with the Agilent Environmental Test Manual and verified to be robust against the environmental stresses of storage, transportation and end-use--those stresses include but are not limited to temperature, humidity, shock, vibration, altitude and power-line conditions. Test methods are aligned with IEC 60068-2 and levels are similar to MIL-PRF-28800F Class 3.

SOFTWARE

Instrument connection software			
	Agilent IO library	The IO library suite offers a single entry point for connection to the most common instruments including AXIe, PXI, GPIB, USB, Ethernet/LAN, RS-232, and VXI test instruments from Agilent and other vendors. It automatically discovers interfaces, chassis, and instruments. The graphical user interface allows you to search for, verify, and update IVI instrument and soft front panel drivers for modular and traditional instruments. The IO suite safely installs in side-by-side mode with NI I/O software.	Free software download at www.agilent.com/find/iosuite
Module setup and usage			
	Agilent soft front panel	The PXI module includes a soft front panel (SFP), a software based graphical user interface (GUI) which enables the instrument's capabilities from your PC.	Included on CD-ROM shipped with module or online
Programming			
Driver	Development environments		
IVI-COM IVI-C LabVIEW MATLAB	Visual Studio (VB.NET, C#, C/C++) VEE LabVIEW, LabWindows/CVI, MATLAB		Included on CD-ROM shipped with module or online
Programming assistance			
	Command Expert	Assists in finding the right instrument commands and setting correct parameters. A simple interface includes documentation, examples, syntax checking, command execution, and debug tools to build sequences for integration in Excel, MATLAB, Visual Studio, LabVIEW, VEE, and SystemVue.	Free software download at www.agilent.com/find/commandexpert
Programming examples	Each module includes programming examples for Visual Studio.net, LabVIEW, MATLAB, LabWindows, and Agilent VEE Pro.		Included on CD-ROM shipped with module or online at www.agilent.com/find/m9381a
Signal generation software			
	Signal Studio	Suite of flexible, easy-to-use, signal creation tools that provides validated and performance optimized reference signals for commonly used communications standards. It configures signals in an easy-to-use, application specific graphical interface and enables you to scale the capability and performance to meet your specific test needs.	Licensed software. For more information, visit www.agilent.com/find/signalstudio
	Waveform Creator	Built around a drag-and-drop graphical user interface, Waveform Creator enables quick development of multi-format, multi-track custom waveforms to be used in the validation and test of digital communications products	Licensed software. For more information, visit www.agilent.com/find/m9099
	SystemVue	System-level EDA software platform for designing communications and defense systems. Used with the M9381A, SystemVue bridges the gap between simulation and prototyping to reduce design iterations and accelerate deployment of emerging wireless technologies.	Licensed software. For more information, visit www.agilent.com/find/systemvue
	MATLAB	Interactive tools and command-line functions for instrument control and data analysis tasks such as signal processing, signal modulation, and digital filtering.	Licensed software. For more information, visit www.agilent.com/find/matlab

SETUP AND CALIBRATION SERVICES

Assistance		
One day startup assistance	Gain access to a technical expert who will help you get started quickly with the M9381A VSG and its powerful software tools. The flexible instruction format is designed to get you to your first measurements and familiarize you with ways to adapt the equipment to a specific application.	Included in base configuration
Calibration and traceability		
Factory calibration	The M9381A VSG ships factory calibrated with an ISO-9002, NIST-traceable calibration certificate.	Included in base configuration
Calibration cycle	A one year calibration cycle is recommended.	
Calibration sites	<ul style="list-style-type: none"> • At Agilent Worldwide Service Centers • On-site by Agilent • By self-maintainers 	For more information visit www.agilent.com/find/infoline
N7800A calibration and adjustment software	The M9381A VSG is supported by Agilent's calibration and adjustment software. This is the same software used at Agilent service centers to automate calibration. The software offers compliance tests for ISO 17025:2005, ANSI/NCSL Z540.3-2006, and measurement uncertainty per ISO Guide to Expression of Measurement Uncertainty.	Licensed software. For more information, visit www.agilent.com/find/calibrationsoftware
Agilent calibration status utility	The Agilent calibration status utility helps ensure your M9381A is calibrated by managing the calibration interval and providing messages regarding instrument and module calibration status.	Included in base configuration

SUPPORT AND WARRANTY

Warranty		
Global warranty	Agilent's warranty service provides standard coverage for the country where product is used. <ul style="list-style-type: none"> • All parts and labor necessary to return to full specified performance • Recalibration for products supplied originally with a calibration certificate • Return shipment 	Included
Standard	Return to Agilent warranty - 3 years 15 days typical turnaround repair service	Included
R-51B-001-5Z	Return to Agilent warranty - 5 years 15 days typical turnaround repair service	
R-51B-001-3X Express warranty 3 years	The express warranty upgrades the global warranty to provide, for 3 years, a 5 day typical turnaround repair service in the US, Japan, China and many EU countries.	Optional
R-51B-001-5X Express warranty 5 years	The express warranty upgrades the global warranty to provide, for 5 years, a 5 day typical turnaround repair service in the US, Japan, China and many EU countries.	Optional
Support		
Core exchange program	Agilent's replacement core exchange program allows fast and easy module repairs. A replacement core assembly is a fully functioning pre-calibrated module replacement that is updated with the defective module serial number, allowing the replacement module to retain the original serial number.	For qualified self maintainers in US only
Self test utility	A self test utility runs a set of internal tests which verifies the health of the modules and reports their status.	Included in base configuration

CONFIGURATION AND ORDERING INFORMATION

Ordering Information

Model	Description
M9381A	PXIe vector signal generator: 1 MHz to 3 or 6 GHz Includes: M9301A PXIe synthesizer M9310A PXIe source output M9311A PXIe digital vector modulator One day startup assistance Module interconnect cables Software, example programs, and product information on CD Return to Agilent warranty - 3 years
Base configuration	
M9381A-F03	Frequency range: 1 MHz to 3 GHz
M9381A-B04	RF modulation bandwidth, 40 MHz
M9381A-M01	Memory, 32 MSa
M9381A-300 Required for warranted specifications	PXIe frequency reference: 10 and 100 MHz Adds M9300A PXIe frequency Reference: 10 and 100 MHz (M9300A module can support multiple M9381A modular instruments)

Configurable options	
Frequency	
M9381A-F03	1 MHz to 3 GHz
✓ M9381A-F06	1 MHz to 6 GHz
Power	
✓ M9381A-1EA	High output power
Switching Speed	
✓ M9381A-UNZ	Fast switching
RF modulation bandwidth	
M9381A-B04	40 MHz
M9381A-B10	100 MHz
✓ M9381A-B16	160 MHz
Memory	
M9381A-M01	32 MSa
M9381A-M05	512 MSa
✓ M9381A-M10	1024 MSa
Other	
✓ M9381A-UNT	Analog modulation
M9381A-UK6	Commercial calibration certificate with test data for M9381A (M9301A, M9310A, M9311A)
M9300A-UK6	Commercial calibration certificate with test data for M9300A (module only)
Related products in recommended configuration	
✓ M9036A	PXIe embedded controller
✓ M9018A	18-Slot PXIe chassis

✓ *Recommended configuration*

CONFIGURATION AND ORDERING INFORMATION

Software Information

Supported operating systems	Microsoft Windows XP (32-bit) Microsoft Windows 7 (32/64-bit) Windows Vista, SP1 and SP2 (32-bit and 64-bit)
Standard compliant drivers	IVI-COM, IVI-C, LabVIEW, MATLAB
Supported application development environments (ADE)	VisualStudio (VB.NET, C#, C/C++), VEE, LabVIEW, LabWindows/CVI, MATLAB
Agilent IO libraries (version 16.3 or newer)	Includes: VISA libraries, Agilent connection expert, IO monitor
Agilent command expert	Instrument control for SCPI or IVI-COM drivers
Signal Studio software:	N7600B W-CDMA/HSPA+ N7601B cdma2000®/1xEV-DO N7602B GSM/EDGE/Evo N7606B <i>Bluetooth</i> ® N7609B Global navigation satellite system
▪ N76xxB-9TP, transportable perpetual license.	N7611B Broadcast radio
▪ N76xxB-9FP, fixed perpetual license.	N7612B TD-SCDMA/HSDPA N7615B Mobile WiMAX™
▪ N7650B-2xx provides 5/50 waveform pack licenses.	N7617B WLAN 802.11a/b/g/n/ac N7623B Digital video N7624B LTE/LTE-Advanced FDD N7625B LTE/LTE-Advanced TDD
(Playback on up to four channels per license)	
Waveform Creator:	
M9099T	Waveform Creator
M9099T-LIC	Core w/utility & multi-tone plug-ins (required)
M9099T-AYA	Digital modulation plug-in
M9099T-SVM	SystemVue plug-in (requires System Vue v2013.08 or later)
M9099T-DFW	File based write unencrypted waveform license
M9099T-XXX-12M	Adds premium support for 1 yr
SystemVue software:	
W1461	SystemVue architect
W1918	LTE-Advanced
W1910	LTE
W1916	3G (GSM/EDGE/CDMA/cdma2000®/W-CDMA/HSPA+)
W1911	WiMAX 802.16e
W1917	WLAN 802.11a/b/g/n/ac
W1915	mmWave WPN 802.15.3c/802.11ad
W1919	Global navigation satellite system DVB-x2
W1914	Radar
W1905	Digital predistortion builder
W1716	

Accessories

Model	Description
Y1212A	Slot blocker kit: 5 modules
Y1213A	PXI EMC filler panel kit: 5 slots
Y1214A	Air inlet kit: M9018A 18-slot chassis
Y1215A	Rack mount kit: M9018A 18-slot chassis
Y1299-001	PXI solutions startup kit - MIMO solution

Related Products

Model	Description
M9021A	PCIe cable interface
M9045B	PCIe express card adaptor for laptop connectivity
Y1200B	PCIe cable for laptop connectivity
M9048A	PCIe desktop adaptor for desktop connectivity
Y1202A	PCIe cable for desktop connectivity
M9380A	PXIe CW source
M9300A	PXIe frequency reference

Advantage services: Calibration and warranty

Agilent Advantage Services is committed to your success throughout your equipment's lifetime

R-51B-001-5Z	Return to Agilent warranty - 5 years
R-51B-001-3X	Express warranty - 3 years
R-51B-001-5X	Express warranty - 5 years
N7800A	Calibration & adjustment software



The modular tangram

The four-sided geometric symbol that appears in this document is called a tangram. The goal of this seven-piece puzzle is to create identifiable shapes—from simple to complex. As with a tangram, the possibilities may seem infinite as you begin to create a new test system. With a set of clearly defined elements—hardware, software—Agilent can help you create the system you need, from simple to complex.

Challenge the Boundaries of Test

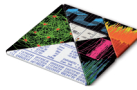

Agilent Modular Products



myAgilent
www.agilent.com/find/myagilent



www.axiestandard.org



www.lxistandard.org



www.pxisa.org



Three-Year Warranty
www.agilent.com/find/ThreeYearWarranty



Agilent Assurance Plans
www.agilent.com/find/AssurancePlans



Agilent Solution Partners
www.agilent.com/find/solutionpartners

Product specifications and descriptions in this document subject to change without notice. PICMG and the PICMG logo, CompactPCI and the CompactPCI logo, AdvancedTCA and the AdvancedTCA logo are US registered trademarks of the PCI Industrial Computers Manufacturers Group. "PCIe" and "PCI EXPRESS" are registered trademarks and/or service marks of PCI-SIG. cdma2000 is a registered certification mark of the Telecommunications Industry Association. Bluetooth and the Bluetooth logos are trademarks owned by Bluetooth SIG, Inc., USA and licensed to Agilent Technologies, Inc. WiMAX and Mobile WiMAX are US trademarks of the WiMAX Forum.

www.agilent.com

www.agilent.com/find/modular

www.agilent.com/find/m9381a

For more information on Agilent Technologies' products, applications or services, please contact your local Agilent office. The complete list is available at: www.agilent.com/find/contactus

Americas

Canada	(877) 894 4414
Brazil	(11) 4197 3600
Mexico	01800 5064 800
United States	(800) 829 4444

Asia Pacific

Australia	1 800 629 485
China	800 810 0189
Hong Kong	800 938 693
India	1 800 112 929
Japan	0120 (421) 345
Korea	080 769 0800
Malaysia	1 800 888 848
Singapore	1 800 375 8100
Taiwan	0800 047 866
Other AP Countries	(65) 375 8100

Europe & Middle East

Belgium	32 (0) 2 404 93 40
Denmark	45 45 80 12 15
Finland	358 (0) 10 855 2100
France	0825 010 700*
	*0.125 €/minute
Germany	49 (0) 7031 464 6333
Ireland	1890 924 204
Israel	972-3-9288-504/544
Italy	39 02 92 60 8484
Netherlands	31 (0) 20 547 2111
Spain	34 (91) 631 3300
Sweden	0200-88 22 55
United Kingdom	44 (0) 118 927 6201

For other unlisted countries: www.agilent.com/find/contactus

(BP-10-02-13)

Product specifications and descriptions in this document subject to change without notice.

© Agilent Technologies, Inc. 2013

Published in USA, December 18, 2013

5991-0279EN



Agilent Technologies