

## About this Manual

We've added this manual to the Agilent website in an effort to help you support your product. This manual is the best copy we could find; it may be incomplete or contain dated information. If we find a more recent copy in the future, we will add it to the Agilent website.

## Support for Your Product

Agilent no longer sells or supports this product. Our service centers may be able to perform calibration if no repair parts are needed, but no other support from Agilent is available. You will find any other available product information on the Agilent Test & Measurement website, [www.tm.agilent.com](http://www.tm.agilent.com).

## HP References in this Manual

This manual may contain references to HP or Hewlett-Packard. Please note that Hewlett-Packard's former test and measurement, semiconductor products and chemical analysis businesses are now part of Agilent Technologies. We have made no changes to this manual copy. In other documentation, to reduce potential confusion, the only change to product numbers and names has been in the company name prefix: where a product number/name was HP XXXX the current name/number is now Agilent XXXX. For example, model number HP8648A is now model number Agilent 8648A.

HP 85133E/F 2.4 mm Flexible Test Port Return Cables  
**Operating and Service Manual**



HP Part No. **85133-90017**  
Microfiche Part No. **85133-90018**  
Printed in USA November 1990

**Edition 1**

---

## Warranty

This Hewlett-Packard instrument product is warranted against defects in material and workmanship for a period of one year **from** date of delivery. During the warranty period, Hewlett-Packard Company will, at its option, either repair or replace products which prove to be defective.

For warranty service or repair, this product must be returned to a service facility designated by HP. Buyer shall prepay shipping charges to HP and HP shall pay shipping charges to return the product to Buyer. However, Buyer shall pay all shipping charges, duties, and taxes for products returned to HP from another country.

HP warrants that its software and firmware designated by HP for use with an instrument will execute its programming instructions when properly installed on that instrument. HP does not warrant that the operation of the instrument, or software, or firmware will be uninterrupted or error free.

### LIMITATION OF WARRANTY

The foregoing warranty shall not apply to defects resulting from improper handling by Buyer, Buyer-supplied software or interfacing, unauthorized modification or misuse, or operation outside of the **environmental** specifications for the product.

NO OTHER WARRANTY IS EXPRESSED OR IMPLIED, HP SPECIFICALLY DISCLAIMS THE IMPLIED WARRANTIES OR MERCHANTABILITY AND FITNESS FOR A PARTICULAR PURPOSE.

### EXCLUSIVE REMEDIES

THE REMEDIES PROVIDED HEREIN ARE BUYER'S SOLE AND EXCLUSIVE REMEDIES, HP SHALL NOT BE LIABLE FOR ANY DIRECT, INDIRECT, SPECIAL, INCIDENTAL, OR CONSEQUENTIAL DAMAGES, WHETHER BASED ON CONTRACT, TORT, OR ANY OTHER LEGAL THEORY.

### Assistance

*Product maintenance agreements and other customer assistance agreements are available for Hewlett-Packard Products.*

*For any assistance, contact your nearest Hewlett-Packard Sales and Service Office. Addresses are provided at the back of this manual.*

# Contents

---

<b>1. General Information</b>	
The Cables . . . . .	<b>1-1</b>
HP 85133F . . . . .	1-1
<b>HP 85133F</b> . . . . .	<b>1-1</b>
Connector Designators . . . . .	1-2
NMD Connectors . . . . .	1-2
PSC Connectors . . . . .	1-2
Incoming Inspection . . . . .	1-2
Handling and Storing Cables . . . . .	1-3
Avoiding Cable Movement . . . . .	1-3
Avoiding Electrostatic Discharge . . . . .	1-3
Replaceable Parts . . . . .	1-4
<b>2. Specifications</b>	
Environmental Specifications . . . . .	2-1
Electrical Specifications . . . . .	2-1
Supplemental Characteristics . . . . .	2-2
<b>3. Performance Tests</b>	
Introduction . . . . .	3-1
Equipment Required . . . . .	3-1
<b>Return Loss</b> . . . . .	3-2
<b>Insertion Loss</b> . . . . .	3-4
<b>4. Replaceable Parts</b>	
Ordering One Cable in a Cable Set . . . . .	4-1
Returning a Cable or Cable Set to HP . . . . .	4-1
More <b>Information</b> . . . . .	4-1
<b>A. Reference</b>	
<b>Connecting and Disconnecting Cables</b> . . . . .	A-1
Connecting a Cable to a Test Port . . . . .	A-2
Disconnecting a Cable <b>From</b> a Test Port . . . . .	A-3
Connecting a Cable to a DUT . . . . .	A-3

## Index

## Figures

---

<b>1-1.</b> Cable Configurations . . . . .	<b>1-1</b>
<b>3-1.</b> Return Loss Test Setup . . . . .	<b>3-3</b>
3-2. Location of the Gates and the Airline . . . . .	3-3
3-3. Insertion Loss Test Setup . . . . .	<b>3-4</b>
<b>A-1.</b> Where to Position Wrenches to Connect or Disconnect an <b>NMD-2.4</b> mm Connector to a Test Port . . . . .	<b>A-2</b>
A-2. Where to Position Wrenches to Connect a <b>2.4</b> mm Connector to a DUT . . . . .	<b>A-4</b>

## Tables

---

<b>2-1.</b> Environmental Specifications . . . . .	<b>2-1</b>
2-2. Electrical Specifications . . . . .	<b>2-1</b>
2-3. Supplemental Characteristics ( <b>1</b> of 3) . . . . .	<b>2-2</b>
<b>3-1.</b> Test Record ( <b>1</b> of 3) . . . . .	<b>3-7</b>
<b>4-1.</b> Replaceable Parts . . . . .	<b>4-2</b>
A-1. Hewlett-Packard <b>Sales</b> and Service Offices . . . . .	<b>A-5</b>

## General Information

---

### The Cables

The Hewlett-Packard **85133E/F** flexible test port return cables (Figure 1-1) are designed for use with **HP 8510** network analyzer test sets that have male NMD-2.4 mm test ports (such as the HP 8516 and 8517).

- HP 85133E** This is a single cable. Use it when a DUT (device under test) is connected, with the appropriate adapter, directly to the test set test port (see Figure 1-la).
- HP 85133F** This is a set of two cables; each is shorter than the HP 85133E cable. Use these cables when a DUT is connected between cable ends (see Figure 1-lb).

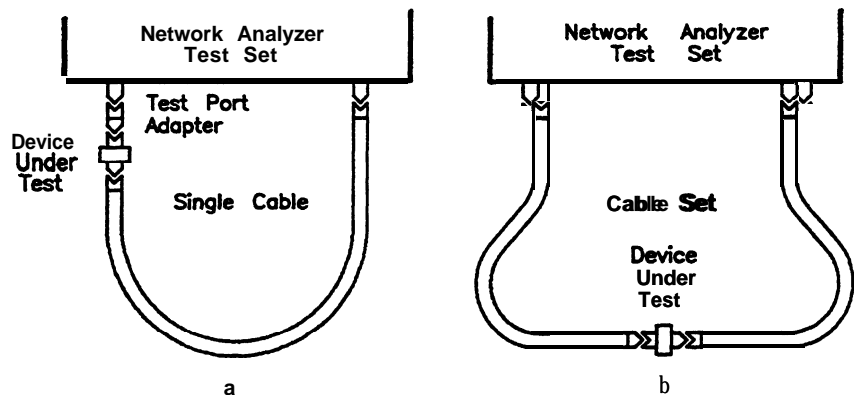

Figure 1-1. Cable Configurations

### Note



This **manual** assumes you know how to properly care for coaxial connectors. If not, refer to Hewlett-Packard's *Microwave Connector Care* for details (see Chapter 4 for ordering information).

---

## Connector Designators

### NMD Connectors

NMD denotes a connector, developed at Hewlett-Packard's Network Measurements Division, that has larger than standard coupling threads (for greater stability). NMD connectors are used on test ports, test port adapters, and test port cables.

Female NMD connectors are used on the test set end of adapters and cables, and *cannot* be connected to standard male **2.4** mm connectors.

Male NMD connectors are used on test sets (as test ports), and on the DUT end of adapters and cables. Male connectors have *both* the larger threads (for use with test port adapters) *and* standard threads (for direct coupling to devices under test).

### PSC Connectors

PSC denotes a precision **slotless** connector. Precision **slotless** connectors are metrology grade connectors that have better electrical performance, better repeatability, and are more durable than slotted connectors.

---

## Incoming Inspection

Use Table 41 to verify that your shipment is complete. To verify the electrical performance of the cable(s), see Chapter 3.

If the packaging material or a cable appears to be damaged, set everything aside and contact the nearest Hewlett-Packard office (see inside the back cover of this manual). Hewlett-Packard will arrange for repair or replacement of incomplete or damaged shipments without waiting for a settlement from the transportation company.

To verify the operation of the cable(s), with an HP 8510, see Table 3-1.

---

## Handling and Storing Cables

Handle cables carefully, and inspect all connectors before you make a connection. When not using a cable, store it in a way that gives it maximum protection.

- Keep connectors clean.
- Do not touch connector mating plane surfaces. Natural skin oils and microscopic particles of dirt are easily transferred to a connector interface, and are very difficult to remove.
- Do not set cable connectors contact-end down on a hard surface. The plating and the mating plane surfaces can be damaged if the interface comes in contact with a hard surface.
- When **you** are not using a cable, use plastic end caps over the connectors to keep them clean and protected.
- Never store cables loose in a box, in a desk, or in a bench drawer. This is the most common cause of connector damage during storage.
- Store cables in the same shape they have when you use them; do not either straighten a cable or flex it more tightly. Even flexible cables last longer if you flex them as little as possible.

### Avoiding Cable Movement

When you use cables to make a precise calibration, you may have to fixture the cables to prevent excessive movement after the calibration. In some cases, unless you restrict cable movement, you may not be able to **perform** a verification after the calibration, especially if you use a *precision* calibration kit.

### Remember!

---

After you perform a calibration, move the test port return cables as little as possible. Every time you bend a cable, the phase changes slightly.

---

### Avoiding Electrostatic Discharge

You must protect against electrostatic discharge before cleaning, inspecting, or connecting connectors attached to a static-sensitive circuit (such as those found in test sets).

Static electricity builds up on the body and can easily damage sensitive internal circuit elements when discharged by contact with the center conductor. Static discharges too **small** to be felt can nevertheless cause permanent damage. Devices such as **calibration** components and devices under test can **also** carry an electrostatic charge.

- Always have a grounded anti-static mat in front of your test equipment, and wear a grounded wrist strap attached to it.
- Ground yourself before you clean, inspect, or making a connection to a static-sensitive device or test port. You can, for example grasp the grounded, outer shell of the test port briefly.



- Discharge static electricity from a device before connecting it: touch the device briefly (through a resistor of at least 2 **MΩ**) to either the outer shell of the test port, or another exposed ground. This discharges static electricity and protects test equipment circuitry.

---

## Replaceable Parts

See Chapter 4 for information on ordering replacement cables (you can order one or the other of the cables in the cable set), and for recommended items not included with the cables.

## Specifications

---

This chapter provides the following:

For	See
Environmental Specifications	Table 2-1
Electrical Specifications	Table 2-2
Supplemental Characteristics	Table 2-3

---

### Environmental Specifications

Table 2-1. Environmental Specifications

Parameter	Specification
Operating Temperature	20° to 26°C (68° to 79°F)
Storage Temperature	-40° to +75°C (-40° to +167°F)
Barometric Pressure Operation	<4,500 metres (15,000 feet)
Storage	<15,000 metres (50,000 feet)
Relative Humidity Operation	Always Non-Condensing 0 to 80% (26°C maximum dry bulb)
Storage	0 to 95%

---

### Electrical Specifications

Table 2-2. Electrical Specifications

HP Cable	SWR	Return Loss (dB)	Insertion Loss (dB)	Frequency Range (GHz)
85133E	≤1.62	≤2.5	≤.58 √f+0.35	DC to 50
85133F			≤0.48 √f+0.25	

1 f = frequency in GHz.

## Supplemental Characteristics

Table 2-3 lists supplemental performance characteristics. These are not specifications, but are intended to provide additional information useful to your application. Supplemental characteristics are typical (but not warranted) performance parameters.

**Table 2-3. Supplemental Characteristics (1 of 3)**

HP Cable	Cable Length		Approximate Electrical Length		Magnitude and Phase Stability <sup>12</sup>	Magnitude and Phase Stability <sup>13</sup>	Minimum Recommended Bend Radius	
	cm	in	m	ft			cm	in
85133E	97.2	38.25	1.125	3.690	<0.25 dB Change <0.16° (f)+0.8°	<0.15 dB Change <0.08° (f)+0.8°	10.2	4
85133F	62.9	24.75	.7376	2.418	<0.17 dB Change <0.16° (f)+0.8°	<0.12 dB Change <0.08° (f)+0.8°		

1 (f) = frequency in GHz

2 With a 90°, four-inch bend radius.

3 after three 90°, four-inch bend radius/straighten cycles.

**Table 2-4. Supplemental Characteristics (2 of 3)**

HP Cable	Number of Cables	Test Set End connector Type	DUT End Connector Type
85133E	1	NMD-2.4 mm <sub>(f)</sub>	PSG2.4 mm <sub>(f)</sub>
85133F	2	NMD-2.4 mm <sub>(f)</sub>	NMD-2.4 mm <sub>(m)</sub> and PSG2.4 mm <sub>(f)</sub>

**2-4. Supplemental Characteristics (3 of 3)**

Precision Connector	Conductor			
	Allowable mm	Recession <sup>1</sup> in	Allowable Protrusion	
NMD-2.4 mm <sub>(f)</sub>	0.0000 to 0.056	0.0000 to 0.0022	0.0000	0.0000
NMD-2.4 mm <sub>(m)</sub>	0.0025 to 0.0127	0.0001 to 0.0005		
PSC-2.4 mm <sub>(f)</sub>	0.0025 to 0.0127	0.0001 to 0.0005		

1 Center conductor shoulder behind outer conductor mating plane.

## Performance Tests

---

### Introduction

Use the following tests to check cable performance. Record the results of the tests on the test record at the end of this chapter.

### Equipment Required

Vector Network Analyzer .....	<b>8510*</b>
Source .....	83651
<b>2.4 mm Test Set .....</b>	<b>8517A</b>
Airline .....	85057-60001
<b>50Ω Load<sub>(m)</sub> .....</b>	00901-60003
<b>50Ω Load<sub>(f)</sub> .....</b>	00901-60004
<b>Short<sub>(m)</sub> .....</b>	85056-60001
<b>Short<sub>(f)</sub> .....</b>	<b>85056-60002</b>

\*With firmware revision 6.0 or greater, option 010 (time domain).

## Return Loss

1. Turn on the network analyzer system. Press **PRESET** and let the system warm up for at least one hour.
  2. Inspect, clean, and gage the cable, airline, and 50 $\Omega$  load connectors.
  3. On the analyzer, press:
    - a. **PRESET**.
    - b. **STIMULUS MENU**.
  4. Select **STEP NUMBER OF POINTS 401**.
  5. At port one of the test set, perform a 2.4 mm one-port  $S_{11}$  calibration with 32 averaging:
    - a. Load the 2.4 mm calibration constants from the tape supplied with the 2.4 mm calibration kit:
      - i. Insert the tape into the analyzer tape drive.
      - ii. Press **TAPE/DISC**.
      - iii. Select **LOAD CAL KIT 1-2 CAL KIT 1 FILE 1**.
      - iv. Press **CAL** and select **CAL 2.4 MM A 1 S<sub>11</sub>1-PORT**.
      - v. Press **RESPONSE MENU** and select **AVERAGE**.
      - vi. Press **3 2 x1**.
      - vii. Connect an open to test port 1 and select **OPEN**.
      - viii. Replace the open with a short and select **SHORT**.
      - ix. Replace the short with a sliding load and select **LOADS BROADBAND LOADS DONE**. Select **SAVE 1-PORT CAL CALSET1**. The softkey **CORRECTION ON** is now underlined.
    - b. Connect the equipment as shown in Figure 3-1.
    - c. On the analyzer, gate out the effects of the terminating load:
      - i. Turn correction on.
      - ii. Press **MENUS DOMAIN**, and select **LINE BANDPASS**.
      - iii. Press **STIMULUS START 0 5 G/n**.
      - iv. For an 85133E cable, press:  
**STIMULUS STOP 9 5 G/n**.
- For an 85133F cable, press:  
**STIMULUS STOP 6 5 G/n**.

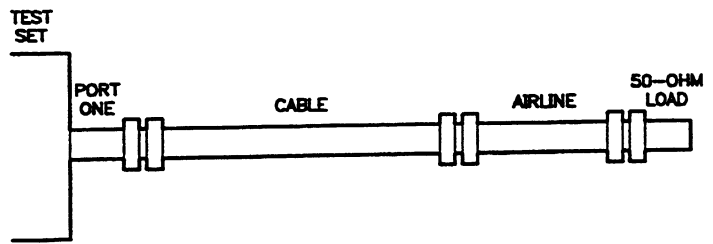

Figure 3-1. Return Loss Test Setup

- v. Press MEASUREMENT **RESTART** and allow one full sweep to complete.
- vi. Press RESPONSE **AUTO** to bring the trace on the screen.
- vii. To activate the stop gate, select **SPECIFY GATE STOP**, and use the RPG knob to adjust the stop gate to the center of the airline (see Figure 3-2).
- viii. Select **GATE ON**.

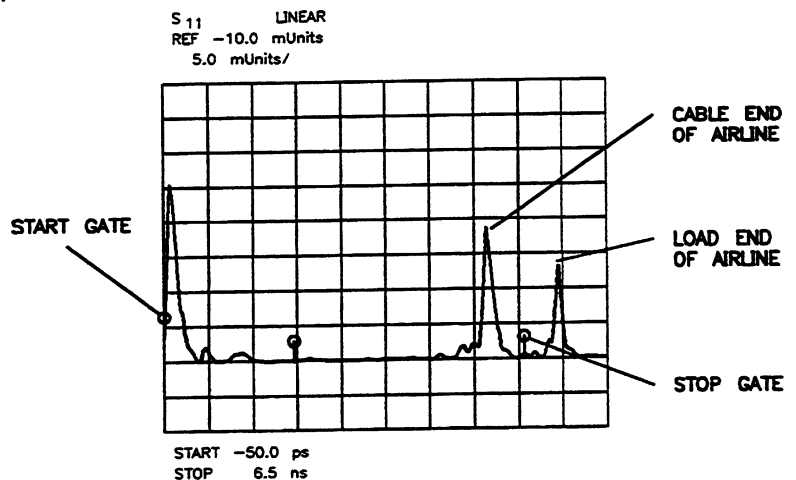
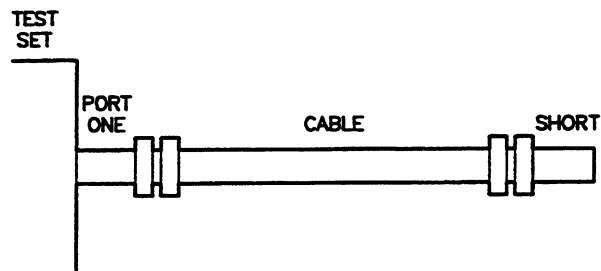

Figure 3-2. Location of the Gates and the Airline

- d. Press **PRIOR MENU** and select **FREQUENCY**.
- e. Press RESPONSE **MENU** and select **SMOOTHING ON**.
- f. Press **2** **x1**.
- g. Press MENUS **MARKER** and select **MORE MAXIMUM**.
- h. Read the return loss value from the screen marker value. Record this number on the test record at the end of this chapter.

## Insertion Loss

1. Connect the equipment as shown in Figure 3-3.
2. Press **PRESET**.
3. Press **STIMULUS MENU** and select **STEP**.



**Figure 3-3. Insertion Loss Test Setup**

4. Recall the one-port calibration saved in the previous test:  
Press **MENUS CAL** and select **CORRECTION ON CAL SET\***.
5. Press **MENUS DOMAIN** and select **TIME BANDPASS**.
6. Press **STIMULUS START** **0** **5** **G/n**.
7. For an HP 85133E cable, press:  
**STIMULUS STOP** **9** **0** **5** **G/n**.  
For an HP 85133F cable, press:  
**STIMULUS STOP** **6** **0** **5** **G/n**.
8. Press **MEASUREMENT RESTART** and allow one full sweep to complete.
9. Press **RESPONSE AUTO**.
10. Press **MENUS MARKER** and select **MORE MAXIMUM**.
11. Press **MENUS DOMAIN** and select **SPECIFY GATE CENTER**.
12. Press **=MARKER**. The marker moves to the maximum response value of the short. The approximate location for the short maximum:  
For an HP 85133E cable: 7.75 ns.  
For an HP 85133F cable: 5.0 ns.
13. Use the front panel knob to adjust the gate center to the marker value.
14. Select **SPAN** and press **0** **3** **G/n**.

15. Select **GATE ON** **PRIOR MENU** **FREQUENCY**.
16. Press MEASUREMENT **RESTART**.
17. Press MENUS **MARKER** and use the front panel knob or the numeric keypad to set the marker to the closest point to the first frequency listed in the test record at the end of this chapter.
18. Divide the values shown on the analyzer by two and record this **value in** the test record.  

The value shown on the analyzer represents an out-and-back path of the signal, which is twice the cable insertion loss
19. Repeat the previous two steps for the remaining values on the test record.





**Table 3-1. Test Record (1 of 3)**

Test Facility _____	Report Number _____
_____	Date _____
_____	Customer _____
_____	Tested by _____
Model _____	Ambient temperature _____ °C
Serial Number _____	Relative humidity _____ %
Options _____	Line frequency _____ Hz (nominal)
Calibration Constants Revision _____	
Special Notes	
_____	
_____	
_____	

**Test Record (2 of 3)**

Model _____	Report Number _____	Date _____
<b>Test Equipment Used</b>	<b>Model Number</b>	<b>Trace Number</b>
1. _____	_____	_____
2. _____	_____	_____
<b>3.</b> _____	_____	_____
<b>4</b> _____	_____	_____
<b>5.</b> _____	_____	_____
6. _____	_____	_____
7. _____	_____	_____
<b>8.</b> _____	_____	_____
9. _____	_____	_____
10. _____	_____	_____

**Test Record (3 of 3)**

Model	HP 85133E/F	Report Number	Date
Test Description	Minimum Spec.	M - d Results	
<b>RETURN LOSS</b>			
HP 85133E	12.5 dB		
HP 85133F <sub>(m)</sub>	12.5 dB		
HP 85133F <sub>(r)</sub>	12.5 dB		
<b>INSERTION LOSS</b>			
HP 85133E:			
At 2 GHz	1.17 dB		
At 8 GHz	1.99 dB		
At 18 GHz	2.81 dB		
At 26 GHz	3.31 dB		
At 40 GHz	4.02 dB		
At 50 GHz	4.45 dB		
HP 85133F <sub>(m)</sub> :			
At 2 GHz	0.93 dB		
At 8 GHz	1.61 dB		
At 18 GHz	2.29 dB		
At 26 GHz	2.70 dB		
At 40 GHz	3.29 dB		
At 50 GHz	3.64 dB		
HP 85133F <sub>(r)</sub> :			
At 2 GHz	0.93 dB		
At 8 GHz	1.61 dB		
At 18 GHz	2.29 dB		
At 26 GHz	2.70 dB		
At 40 GHz	3.29 dB		
At 50 GHz	3.64 dB		

## Replaceable Parts

---

Table 4-1 lists the replacement part numbers. To order a listed part, note the description, HP part number, and the quantity desired. Telephone or send your order to the nearest Hewlett-Packard office (see inside the back cover of this manual).

---

### Ordering One Cable in a Cable Set

If you need only one of the cables in a set and don't want to order a cable set, use the appropriate single cable part number listed in Table 4-1. When you order a single cable, you do not get a pair; be *sure* you order the correct cable.

---

### Returning a Cable or Cable Set to HP

If a cable or cable set requires service, contact the HP office nearest you for information on where to send it (sales and service offices are listed inside the back cover of this manual). When you send the cable or cable set to Hewlett-Packard, include a service tag (found at the end of this manual), on which you provide the following information:

1. Your company name and address.
2. A technical contact person within your company, and their complete phone number.
3. If you are returning a complete kit, include the model number and serial number.
4. If you are returning one or more devices, include the part number(s) and serial number(s).
5. Indicate the type of service required.
6. Include any applicable information.

---

### More Information

This manual contains limited information about network analyzer system operation. For complete information, refer to the instrument documentation.

If you need additional information, contact your local **Hewlett-Packard** representatives (sales and service offices are listed inside the back cover of this manual).

**Table 4-1. Replaceable Parts**

Description	Quantity Per Kit	HP Replacement Part Number
<b>Cables</b>		
HP 85133E Single Flexible Cable: NMD-2.4 <b>mm<sub>(f)</sub></b> to PSG2.4 <b>mm<sub>(f)</sub></b>	1	85133-60015
HP 85133F Flexible Cables: NMD-2.4 <b>mm<sub>(f)</sub></b> to NMD-2.4 <b>mm<sub>(m)</sub></b>	1	85133-60017
NMD-2.4 <b>mm<sub>(f)</sub></b> to PSG2.4 <b>mm<sub>(f)</sub></b>	1	85133-60016
<b>Protective End Caps</b>		
NMD-2.4 <b>mm<sub>(f)</sub></b>	3	1401-0214
NMD-2.4 <b>mm<sub>(m)</sub></b>	1	1401-0208
PSC-2.4 <b>mm<sub>(f)</sub></b>	2	1401-0202
<b>HP 85133E/F Documentation</b>		
Manual	1	85133-90017
Microfiche		85133-90018
<b>Items Not Included in Kit</b>		
Spanner Wrench		<b>8720-0011</b>
20 mm (8 in-lb) Torque <b>Wrench<sup>1</sup></b>		<b>8710-1767</b>
<b>5/16</b> in (8 in-lb) Torque <b>Wrench<sup>2</sup></b>		8710-1765
2.4 mm Connector Gage <b>Set<sub>(m)</sub><sup>2</sup></b>		85056-60018
2.4 mm Connector Gage <b>Set<sub>(f)</sub><sup>2</sup></b>		85056-60017
2.4 mm <b>50Ω</b> Fixed <b>Termination<sub>(m)</sub><sup>2</sup></b>		<b>00901-60001</b>
2.4 mm <b>50Ω</b> Fixed <b>Termination<sub>(f)</sub><sup>2</sup></b>		00901-60002
2.4 mm <b>Offset Short<sub>(m)</sub><sup>2</sup></b>		85056-60001
2.4 mm <b>Offset Short<sub>(f)</sub><sup>2</sup></b>		85056-60002
2.4 mm <b>Airline (5.0 cm)<sup>3</sup></b>		85057-60008
Isopropyl Alcohol (8 oz)		8500-0559
Isopropyl Alcohol (30 <b>ml</b> squeeze-top bottle)		8500-5344
Foam Swabs (500)		<b>9300-1270</b>
Alcohol Wipes		<b>92193N</b>
Connector Care Manual		<b>08510-90064</b>

**1** Included with the test set.

**2** Included with the HP 85056A calibration kit.

**3** Included with the HP 85057B verification kit.

## Reference

---

### *Connecting and Disconnecting Cables*

**Remember**



---

The most common cause of measurement error is poor connections.

---

Good connections require a skilled operator. Instrument sensitivity and coaxial connector mechanical tolerances are such that slight errors in operator technique can have a significant effect on measurements and measurement uncertainties.

**Remember**

---

After you perform a calibration, move the test port return cables as little as possible. Every time you bend a cable, the phase changes slightly.

---

## Connecting a Cable to a Test Port

1. Ground yourself and **all** devices (wear a grounded wrist strap, and work on a static mat).
2. Visually and mechanically inspect the connectors.
3. **If** necessary, clean the connectors.
4. Carefully align the connectors. The male connector center pin must slip concentrically into the contact fingers of the **female** connector.
5. Push the connectors straight together. **Do not** twist or screw them together. As the center conductors mate, there is usually a slight resistance.

### Caution



Do **not** twist one connector into the other (like inserting a light bulb). This happens if you turn the device body rather than the connector nut.

6. The preliminary connection is tight enough when the mating plane surfaces make uniform, light contact. Do not over tighten.
7. To assure consistent torque in the following steps, relieve any side pressure on the connection.
8. Using the spanner wrench supplied with the HP 8510, hold the cable stationary (see Figure A-1 for wrench placement).

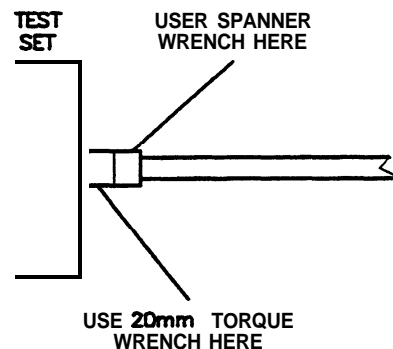

**Figure A-1.**

**Where to Position Wrenches to Connect or Disconnect an NMD-2.4 mm Connector to a Test Port**

9. Using a 20 mm (8 in-lb) torque wrench, tighten the connection (see Figure A-1 for wrench placement).
10. Using an anti-rotation clamp (supplied with the test set), secure the cable to the test set.

---

## Disconnecting a Cable From a Test Port

### Note

3

---

A void **lateral** (bending) force on the connector mating plane surfaces.

---

1. Using the spanner wrench, hold the cable stationary (see Figure A-1 for wrench placement).
  2. Using a 20 mm (8 in-lb) torque wrench, loosen the test set nut.
  3. Complete the disconnection by hand, turning only the connector nut.
- 

### Caution



---

Do **not** twist one connector out of the other (like removing a light bulb). This happens if you turn the device body rather than the connector nut.

---

4. Pull the connectors **straight** apart.
- 

---

## Connecting a Cable to a DUT

1. Ground yourself and **all** devices (wear a grounded wrist strap, and work on a static mat).
  2. Visually and mechanically inspect **all** connectors. Always measure the pin depth of the DUT; a protruding center conductor can permanently damage a cable.
  3. If necessary, clean all connectors.
  4. Carefully align the connectors. The **male** connector center pin must slip concentrically into the contact **fingers** of the female connector.
  5. Push the connectors straight together. **Do not** twist or screw them together. As the center conductors mate, there is usually a slight resistance.
- 

### Caution



---

Do **not** twist one connector into the other (like inserting a light bulb). This happens if you turn the device body rather than the connector nut.

---

6. The preliminary connection is tight enough when the mating plane surfaces make uniform, light contact. Do not over tighten.
7. To assure consistent torque in the following steps, relieve any side pressure on the connection.



**8. For a Male Cable Connector:**

Using a 20 mm torque wrench, rotate the connector nut on the *male cable* (see Figure A-2).

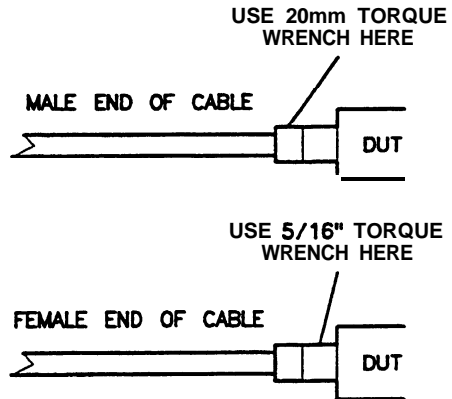

**Figure A-2.**  
Where to Position Wrenches to Connect  
a 2.4 mm Connector to a DUT

**9. For a Female Cable Connector:**

Hand tighten the **5/16** inch nut on the *DUT*.

Using a **5/16** inch torque wrench, rotate the *DUT* connector nut onto the female cable connector (see Figure A-2).

**Table A-1. Hewlett-Packard Sales and Service Offices**

<p><b>IN TEE UNITED STATES</b>  <b>California</b>                      Hewlett-Packard Co.                      1421 South Manhattan Ave.                      P.O. Box 4230                      Fullerton, CA 92631                      (714) 999-6700</p>	<p><b>IN AUSTRALIA</b>                      Hewlett-Packard Australia Ltd.                      31-41 Joseph Street                      Blackburn, Victoria 3130  <b>895-2895</b></p>	<p><b>IN JAPAN</b>                      Yokogawa-Hewlett-Packard Ltd.  <b>29-21 Takaido-Higashi</b>, 3 Chome                      Suginami-ku Tokyo 168                      (03) 331-6111</p>
<p>Hewlett-Packard Co.                      301 E. Evelyn                      Mountain View, CA 94039                      (415) 6942000</p>	<p><b>IN CANADA</b>                      Hewlett-Packard (Canada) Ltd.                      17500 South Service Road  <b>Trans-Canada</b> Highway                      Kirkland, Quebec <b>H9J 2X8</b>                      (514) 697-4232</p>	<p><b>IN PEOPLE'S REPUBLIC OF CHINA</b>                      China Hewlett-Packard, Ltd.                      P.O. Box 9610, Beijing                      4th Floor, 2nd Watch Factory                      Main Bldg.  <b>Shuang Yu Shu, Bei San Huan Rd.</b>                      Beijing, <b>PRC</b>  <b>256-6888</b></p>
<p><b>Colorado</b>  <b>Hewlett-Packard</b> Co.                      24 Inverness Place, East                      Englewood, CO 80112  <b>(303) 649-5000</b></p>	<p><b>IN FRANCE</b>                      Hewlett-Packard France                      F-91947 Les Ulis <b>Cedex</b>  <b>Orsay</b>  <b>(6) 907-78-25</b></p>	<p><b>IN SINGAPORE</b>                      Hewlett-Packard <b>Singapore</b>                      Pte. Ltd.                      1150 Depot Road                      Singapore 0410  <b>273 7388</b>                      Telex HPSGSO <b>RS34209</b>                      Fax (65) 2788990</p>
<p><b>Georgia</b>  <b>Hewlett-Packard</b> Co.                      2000 South Park Place                      P.O. Box 105005  <b>Atlanta, GA 30339</b>  <b>(404)955-1500</b></p>	<p><b>IN GERMAN FEDERAL REPUBLIC</b>                      Hewlett-Packard <b>GmbH</b>  <b>Vertriebszentrale</b> Frankfurt                      Berner <b>Strasse</b> 117                      Postfach 560 140  <b>D- 6000</b> Frankfurt 56                      (0611) 50-04-1</p>	<p><b>IN TAIWAN</b>                      Hewlett-Packard Taiwan                      8th Floor, Hewlett-Packard                      Building                      337 <b>Fu</b> Hsing North Road                      Taipei  <b>(02) 712-0404</b></p>
<p><b>Illinois</b>  <b>Hewlett-Packard</b> Co.                      5201 Tollview Drive  <b>Rolling</b> Meadows, IL 60008                      (312) 255-9800</p>	<p><b>IN GREAT BRITAIN</b>                      Hewlett-Packard Ltd.                      King Street Lane                      Winnersh, Wokingham                      Berkshire <b>RG11 5AR</b>  <b>0734 784774</b></p>	<p><b>IN ALL OTHER LOCATIONS</b>                      Hewlett-Packard Inter-Americas                      3495 Deer Creek Rd.                      Palo <b>Alto</b>, California 94304</p>
<p><b>New Jersey</b>  <b>Hewlett-Packard</b> Co.                      120 W. Century Road  <b>Paramus, NJ 07653</b>  <b>(201) 265-5000</b></p>	<p><b>IN OTHER EUROPEAN COUNTRIES</b>                      Hewlett-Packard (Schweiz) AG  <b>Allmend 2</b>                      CH-8967 Widen (Zurich)                      (0041) 57 31 21 11</p>	
<p><b>Texas</b>  <b>Hewlett-Packard</b> Co.                      930 E. Campbell Rd.  <b>Richardson, TX 75081</b>                      (214) 231-6101</p>		



# Index

---

## 8

**85133E/F** description, 1-1

## B

bend radius, 2-2

## C

### cable

- 85133E/F**, 1-1
  - configuration, 1-1
  - connecting, A-1
  - connectors, 2-2
  - description, 1-1
  - disconnecting, A-1
  - handling, 1-2
  - length, 2-2
  - moving, 1-3
  - ordering, 4-1
  - replacing**, 4-1
  - returning, 4-1
  - storing, 1-2
  - using one, 1-1
  - using two, 1-1

### calibration

- cable movement**, 1-3

- care of connectors**, 1-1

### center conductor

- protrusion, **2-2**

- recession**, 2-2

- characteristics, supplemental, 2-1

- configuration, cable**, 1-1

- connecting cables, 1-1, A-1

### connector

- cable ends, 2-2

- care of, 1-1

- designators, 1-2

- NMD, 1-2

- PSC**, 1-2

- publications**, 1-1

- connector names, 1-2

## D

- damage, electrostatic discharge, 1-3

- designators, connector**, 1-2

- discharge, electrostatic, 1-3

- disconnecting cables, A-1

## DUT

- connecting, 1-1

## E

- electrical length, 2-2

- electrical specifications, 2-1

- electricity, static, 1-3

- electrostatic **discharge** (ESD), 1-3

## F

- flexing cables, 1-3

## H

- handling cables, 1-2

## I

- incoming inspection, 1-2

- information, where to find** more, **4-1**

## L

- length, physical and electrical, 2-2

## M

- magnitude** and phase stability, 2-2

- moving, cable, 1-3

## N

- names, of **connectors**, 1-2

- NMD connector, 1-2

## P

- parts, replaceable, 4-1

- performance parameters, typical, 2-1

- performance test**, **3-1**

- phase and magnitude stability, 2-2

- physical length, 2-2

- protrusion, center** conductor, 2-2

- PSC connector, 1-2

## R

- radius, bend, 2-2

- replaceable parts, 4-1

- returning a cable** or cable set, 4-1

## **S**

specifications

electrical, 2-1

environmental, 2-1

stability, magnitude and phase, 2-2

static electricity, **1-3**

storing cables, 1-2

supplemental characteristics, 2-1

## **T**

test, performance, **3-1**

test record, **3-8-9**

typical **performance, 2-1**