

Errata

Title & Document Type: 438A Power Meter Operating and Service Manual

Manual Part Number: 00438-90028

Revision Date: 1986-04-01

HP References in this Manual

This manual may contain references to HP or Hewlett-Packard. Please note that Hewlett-Packard's former test and measurement, semiconductor products and chemical analysis businesses are now part of Agilent Technologies. We have made no changes to this manual copy. The HP XXXX referred to in this document is now the Agilent XXXX. For example, model number HP8648A is now model number Agilent 8648A.

About this Manual

We've added this manual to the Agilent website in an effort to help you support your product. This manual provides the best information we could find. It may be incomplete or contain dated information, and the scan quality may not be ideal. If we find a better copy in the future, we will add it to the Agilent website.

Support for Your Product

Agilent no longer sells or supports this product. You will find any other available product information on the Agilent Test & Measurement website:

www.tm.agilent.com

Search for the model number of this product, and the resulting product page will guide you to any available information. Our service centers may be able to perform calibration if no repair parts are needed, but no other support from Agilent is available.

Operating and Service Manual

HP 438A Power Meter

SERIAL NUMBERS

Attached to the rear panel of the instrument is a serial number plate. The serial number is in the form: 0000A00000 and 0000U00000. The first four digits and the letter are the serial number prefix. The last five digits are the suffix. The prefix is the same for identical instruments; it changes only when a configuration change is made to the instrument. The suffix, however, is assigned sequentially and is different for each instrument.

This manual applies to instruments with serial numbers prefixed 3008A or 3017U and above. For additional important information about serial numbers, see "Instruments Covered By This Manual" in Chapter 1.

This manual does not contain any backdating information. If backdating information is required for operating or repairing your HP 438A with serial prefix 2822A or 2839U and below, you must purchase manual part number 00438-90015.



HP Part No. 00438-90028

© HEWLETT-PACKARD Ltd. 1983, 1986, 1991, 1992, 1993
Station Road, West Lothian, Scotland, EH30 9TG.
Printed in UK

Acoustic Noise Emissions

This document adds acoustical noise emissions specifications and general characteristics to the HP 438A operating information to comply with and to show conformance to the third regulation to the German Equipment Safety Law for the Regulation on Noise Declaration for Machines: 3.GSGV.

Specifications are parameters against which the instrument can be tested. General characteristics are non-warranted parameters included as useful information.

Geraeuschemission

Acoustic Noise Emissions / Geraeuschemission

Specifications	Spezifikation
LpA: < 70 dB (A) per ISO 3744	LpA < 70 dB (A) nach DIN 45635 pt. 1
General Characteristics*	Generelle Eigenschaften*
LpA: Operator Position: 47 dB (typ.) Bystander Position: 39 dB (typ.) per ISO 6081 <i>*Based on type test</i>	LpA: am Arbeitsplatz: 47 dB (typ.) fiktiver Arbeitsplatz: 39 dB (typ.) nach DIN 45635 pt. 19 <i>*Typprüfungsergebnis</i>

NOTICE

The information contained in this document is subject to change without notice.

HEWLETT-PACKARD MAKES NO WARRANTY OF ANY KIND WITH REGARD TO THIS MANUAL, INCLUDING, BUT NOT LIMITED TO, THE IMPLIED WARRANTIES OF MERCHANTABILITY AND FITNESS FOR A PARTICULAR PURPOSE. Hewlett-Packard shall not be liable for errors contained herein or direct, indirect, special, incidental or consequential damages in connection with the furnishing, performance, or use of this material.

WARRANTY

A copy of the specific warranty terms applicable to your Hewlett-Packard product and replacement parts can be obtained from your local Sales and Service Office.

Herstellerbescheinigung

Hiermit wird bescheinigt, daß dieses Gerät/System in Übereinstimmung mit den Bestimmungen von Postverfügung 1046/84 funkentstört ist.

Der Deutschen Bundespost wurde das Inverkehrbringen dieses Gerätes/System angezeigt und die Berechtigung zur Überprüfung der Serie auf Einhaltung der Bestimmungen eingeräumt.

Zusatzinformation für Meß- und Testgeräte:

Werden Meß- und Testgeräte mit ungeschirmten Kabeln und/oder in offenen Meßaufbauten verwendet so ist vom Betreiber sicherzustellen, daß die Funkentstörbedingungen unter Betriebsbedingungen an seiner Grundstücksgrenze eingehalten werden.

Manufacturer's Declaration

This is to certify that this equipment is in accordance with the Radio Interference Requirements of Directive FTZ 1046/1984. The German Bundespost was notified that this equipment was put into circulation, and has been granted the right to check the equipment type for compliance with these requirements.

Note: If test and measurement equipment is operated with unshielded cables and/or used for measurements in open setups, the user must ensure that under these operating conditions, the radio frequency interference limits are met at the border of his premises.

Safety Considerations

This product and related documentation must be reviewed for familiarization with safety markings and instructions before operation.

This product is a Safety Class I instrument (provided with a protective earth terminal).

Before Applying Power

Verify that the product is set to match the available line voltage and the correct fuse is installed.

Safety Earth Ground

An uninterruptible safety earth ground must be provided from the main power source to the product input wiring terminals, power cord, or supplied power cord set.

Warning



Any interruption of the protective (grounding) conductor (inside or outside the instrument) or disconnecting the protective earth terminal will cause a potential shock hazard that could result in personal injury. (Grounding one conductor of a two conductor outlet is not sufficient protection.) In addition, verify that a common ground exists between the unit under test and this instrument prior to energizing either unit.

Whenever it is likely that the protection has been impaired, the instrument must be made inoperative and be secured against any unintended operation.

If this instrument is to be energized via an autotransformer (for voltage reduction) make sure the common terminal is connected to neutral (that is, the grounded side of the mains supply).

Servicing instructions are for use by service-trained personnel only. To avoid dangerous electric shock, do not perform any servicing unless qualified to do so.

Adjustments described in the manual are performed with power supplied to the instrument while protective covers are removed. Energy available at many points may, if contacted, result in personal injury.

Capacitors inside the instrument may still be charged even if the instrument has been disconnected from its source of supply.

For continued protection against fire hazard, replace the line fuse(s) only with 250V fuse(s) of the same current rating and type (for example, normal blow, time delay, etc.). Do not use repaired fuses or short circuited fuseholders.

Safety Symbols



Instruction manual symbol: The product will be marked with this symbol when it is necessary for the user to refer to the instruction manual (see Table of Contents for page references).



Indicates hazardous voltages.



Indicates earth (ground) terminal.

Warning



The **WARNING** sign denotes a hazard. It calls attention to a procedure, practice, or the like, which, if not correctly performed or adhered to, could result in personal injury. Do not proceed beyond a **WARNING** sign until the indicated conditions are fully understood and met.

Caution



The **CAUTION** sign denotes a hazard. It calls attention to an operating procedure, practice, or the like, which, if not correctly performed or adhered to, could result in damage to or destruction of part or all of the product. Do not proceed beyond a **CAUTION** sign until the indicated conditions are fully understood and met.

General Information

Introduction

This manual contains information required to install, operate, test, and service the Hewlett-Packard 438A Power Meter. The power meter is shown in FIGURE 1-1 with all of its externally supplied accessories. This manual also documents Option 002 which adds the capability of rear panel sensor inputs and a second reference oscillator output.

This section of the manual covers the instrument description, options, accessories, specifications, and other basic information. The remaining sections cover the following information.

- Section 2 Installation
- Section 3 Operation
- Section 4 Performance Tests
- Section 5 Adjustments
- Section 6 Replaceable Parts
- Section 7 Manual Changes
- Section 8 Service

Two copies of the operating information are supplied with the power meter. One copy is in the form of an Operating Manual and is simply a copy of the first three sections of the Operating and Service Manual. It should remain with the instrument for use by the operator. The other copy provided is the Operating and Service Manual which should be retained by the technicians responsible for the periodic servicing of the instrument. Additional copies of either manual may be ordered through your nearest Hewlett-Packard sales office. The part numbers are listed on the title page of this manual.

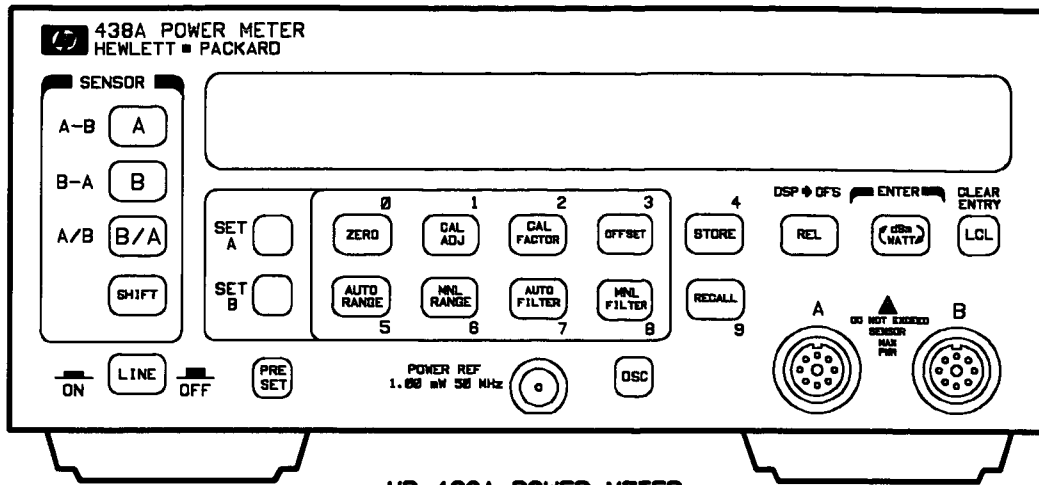

HP 438A POWER METER

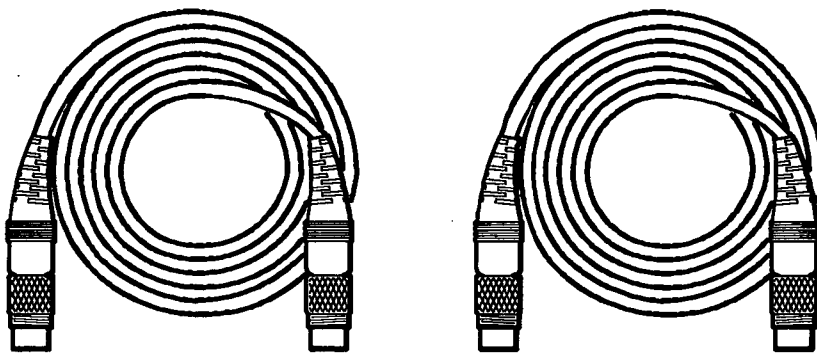

POWER SENSOR CABLES

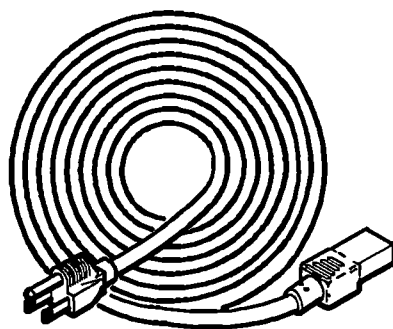

LINE POWER CABLE

Figure 1-1. HP 438A Power Meter with Accessories Supplied.

1-2. Specifications

Instrument specifications are listed in Table 1-1. These specifications are the performance standards or limits against which the instrument may be tested. Supplemental characteristics are listed in Table 1-2. Supplemental characteristics are not warranted specifications, but are typical characteristics included as additional information for the user.

1-3. Safety Considerations

This product is a Safety Class I instrument, that is, one provided with a protective earth terminal. The power meter and all related documentation must be reviewed for familiarization with safety markings and instructions before operation. Refer to the "Safety Considerations" page found at the beginning of this manual for a summary of the safety information. Safety information for installation, performance testing, adjustment, and service will be found in appropriate places throughout this manual.

1-4. Instruments Covered by this Manual

Attached to the rear panel of the instrument is a serial number plate. The serial number is in the form: 0000A00000 and 0000U00000. The first four digits and the letter constitute the serial number prefix. The last five digits are the suffix. The prefix is the same for identical instruments; it changes only when a configuration change is made to the instrument. The suffix however, is assigned sequentially and is different for each instrument. The contents of this manual apply directly to instruments having the same serial number prefix(es) listed under Serial Numbers on the title page.

1-5. Manual Changes Supplement

An instrument manufactured after the printing of this manual may have a serial number prefix that is not listed on the title page. This unlisted serial number prefix indicates that the instrument is different from those documented in the manual. If manual changes are needed, the manual for this newer instrument is accompanied by a yellow Manual Changes supplement. The supplement contains "change information" that explains how to adapt this manual to the newer instrument.

In addition to change information, the supplement may contain information for correcting errors in the manual. The supplement is identified with the manual print date and part number, both of which appear on the manual title page.

For information concerning a serial number prefix that is not listed on the title page or in the Manual Changes supplement, contact your nearest Hewlett-Packard office.

1-6. Description

The HP 438A Power Meter is a microprocessor controlled dual channel (A and B multiplexed) meter. It measures power in the range of -70 to $+44$ dBm over the frequency range of 100 kHz to 26.5 GHz using the existing Hewlett-Packard 8480 series power sensors. A 1.00 mW 50 MHz POWER REF (reference) is available for calibrating the meter to the sensor's sensitivity.

The meter displays power in the following modes; dBm, dB Rel (relative), watts and % Rel (per cent relative). The measured ratio and difference of two inputs can be displayed. The power ratio is displayed in either dB or % while the power difference is displayed in either watts or dBm. The ratio or difference power readings of a single sensor input are displayed relative to a stored reference. Also displayed are the possible error states of the meter.

Zeroing, calibration, and offsets are capabilities of the meter that can be set either locally by the front panel keys or remotely over the Hewlett Packard Interface Bus (HP-IB). When these routines are finished the meter resumes measuring and displaying the input power.

The meter has both manual and automatic ranging. In the AUTO RANGE mode the meter automatically switches through its five ranges and in the MNL RANGE (manual range) mode one of the five ranges can be selected.

Memory capacity for saving up to 19 front panel settings is built into the meter and can be accessed by using **STORE** and **RECALL**.

1-6. Options

1-7. Electrical Options

Option 002 provides the additional capability of having two power input connectors on the rear panel in parallel with the front panel inputs and a rear panel connector for an additional power reference oscillator. If Option 002 was not initially ordered with the power meter, the option can be added by ordering the Option 002 retrofit kit HP part number 00438-60044.

Option 004 deletes the two HP 11730A Sensor Cables normally supplied with the power meter. Refer to paragraph "1-12. Cables" in this section for other cables available.

1-8. Mechanical Option

A mechanical option kit is available containing hardware and installation instructions for adding handles to the meter. To obtain front handle kit Option 907 order HP part number 5061-9688.

1-9. Accessories Supplied

The accessories supplied with the power meter are shown in Figure 1-1. The line power cable will be supplied in one of several configurations, depending upon the country of destination for the original shipment from the factory. Refer to "Power Cables" in section 2 of this manual. Two power sensor cables, HP part number 11730A, are supplied.

1-10. Accessories Available

1-11. Rack Mounting Kits

These kits are very useful when the power meter is to be rack mounted. It permits access to internal circuits and components, and access to the rear panel is possible without removing the instrument from the rack.

Rack mounting one power meter. Order HP part number 5062-3972. This kit includes one rack flange and one extension adapter.

Rack mounting two power meters. Order the following: HP part number 5062-3974 two rack flanges, and HP part number 5061-9694 cabinet locking hardware.

Rack mounting one power meter with slides. Order the following: HP part number 5062-3996 support shelf, HP part number 1494-0064 two slides, and HP part number 5062-4022 filler panel.

Rack mounting two power meters with slides. Order the following: HP part number 5062-3966 support shelf, and HP part number 1494-0064 two slides.

1-12. Cables

Power sensor cables of various lengths are available. The model numbers and lengths are listed below.

HP 11730A 1.5m (5ft)
HP 11730B 3.0m (10ft)
HP 11730C 6.1m (20 ft)
HP 11730D 15.2m (50 ft)
HP 11730E 30.5m (100ft)
HP 11730F 61.0m (200ft)

**1-13. Recommended
Test Equipment**

Table 1-3 lists the test equipment recommended for use in testing, adjusting, and servicing the power meter. If any of the recommended equipment is not available, instruments with equivalent critical specifications may be substituted.

Table 1-1 lists the power meter's performance specifications. The following conditions apply to all specifications:

- a. The power meter must have a one-half hour warm-up for all specifications.
- b. The line voltage for all instruments must be 100, 120, 220, or 240 Vac +5%, -10%, and the line frequency must be 48 to 66 Hz.
- c. The ambient temperature must be 0° to 55°C.

Table 1-1. Specifications

Electrical Characteristics	Performance Limits	Conditions
Meter		
Frequency range	100 kHz to 26.5 GHz	Sensor dependent
Power range	-70 dBm to +44 dBm (100 pW to 25W)	Sensor dependent
Dynamic range	50 dB total range	5 ranges of 10 dB steps for 50 dB total
Inputs		
Rear panel output	Channel A and B 0-1 volt analog	Multiplexed dual sensors Without digital filtering 1kΩ output impedance BNC connector
Measurement modes	A, B, A-B, B-A, A/B, B/A	Normal or relative all modes
Display units		
	Watts or dBm	Absolute A, B, A-B, B-A
	Percent or dB	Ratio A/B, B/A
	Percent or dB	Relative
Resolution		
Normal	0.1% full scale (0.01 dB) 0.01 dB	Auto filter watts or percent dBm or dB
High	0.01% full scale 0.001dB	Manual filter watts or percent dBm or dB
Accuracy		
Instrumentation, includes sensor linearity ¹		
Single channel mode:	±0.02 dB Plus ±0.02 dB	Within same calibration range Outside calibration range
Dual channel mode: ² (ratio or difference)	Multiply single channel specifications by 2	
Zero set (digital settability of zero)	±0.5% full scale	Most sensitive range. Decrease percentage by a factor of 10 for each higher range ± one count.
EMI		
	Radiated and Conducted Emissions and Radiated and Conducted Susceptibility are within the requirements of RE02, CE03, RS01/03 and CS01/02 called out in MIL-STD-461C, and within the requirements of VDE 0871 and CISPR Publication 11.	

1 When operating in Range 5, add the corresponding sensor power linearity percentage.

2 Accuracy does not depend on the meter being in Normal or Relative mode.

Table 1-1. Specifications (continued)

Electrical Characteristics	Performance Limits	Conditions
Power reference	1.00 mW	Internal 50 MHz oscillator factory set to $\pm 0.7\%$ traceable to National Bureau of Standards.
Power reference accuracy	$\pm 1.2\%$ $\pm 0.9\%$	Worst case RSS for one year.
General		
Operating temperature range	0° C to 55° C	
Power Requirements	65 VA, 35 watts	Maximum
Line Voltage	100, 120, 220, or 240 Vac, +5% to -10%	
Line Frequency	48 to 66 Hz 360 to 440 Hz	All specified line voltages may be used. Limited to line voltages of 100 or 120 Vac.
Power Dissipation	<10 VA (8 watts max)	
Remote Operation	HP-IB	All functions except power switch, clear entry, HP-IB address
Compatibility	HP-IB interface	SH1, AH1, T5, TE0, L3, LE0, SR1, RL1, PP1, DC1, DT1, C0
Memory	Non-volatile	Contains complete meter operating state of both channels plus contents of store/recall registers
Operating and non-operating environment	Temperature, humidity, shock, and vibration type tested to MIL-T-28800B Class V requirements.	
Safety	Meets requirements of IEC 348	
Net weight	5.9 kg (13 lbs.)	
Dimensions	89mm H x 213mm W x 418mm D (3.5 H x 8.4 W x 16.8 inches D) (3.5 H x 8.4 W x 16.8 inches D)	EIA and IEC racking standards: 3.5 H x 0.5 W x 17 D

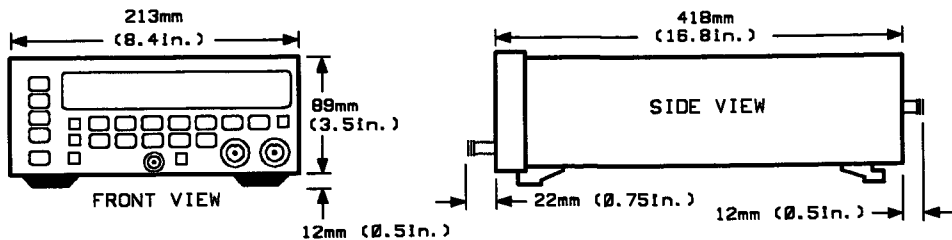

Note: For ordering cabinet accessories, the module sizes are 3-1/2H, 1/2MW, and 17D.

Table 1-2. Supplemental Characteristics

<p>Zero drift of sensors As a % of full scale, 1 hour, at constant temperature after 24 hours warmup.</p>	
<p>Sensors: HP 8481A, 8481B, 8481H, 8482A, 8482B, 8482H, 8483A, 8485A:</p>	<p>±0.1% of full scale on range 1.</p>
<p>Sensors: HP 8484A: Decrease percentage by a factor of 10 for each higher range.</p>	<p>±2.0% of full scale on range 1.</p>
<p>Measurement speed Over HP-IB and free running trigger.</p>	
<p>Single channel</p>	<p>20 readings per second</p>
<p>Dual channel</p>	<p>2 readings per second</p>
<p>Channel switching delay</p>	<p>200 ms</p>
<p>Power reference</p>	
<p>Frequency</p>	<p>50 MHz nominal</p>
<p>SWR</p>	<p>1.05 maximum</p>
<p>Connector</p>	<p>Type N female</p>
<p>Meter adjustments:</p>	
<p>CAL FACTOR</p>	<p>Key pad entry or programmable. Sets calibration factor for the meter. Overrides current value. Range: 1-150% in 0.1% increments.</p>
<p>ZERO</p>	<p>Key pad entry or programmable. Zeros all 5 ranges, reference oscillator automatically switched off during zeroing.</p>
<p>CAL ADJ</p>	<p>Automatic, key pad entry or programmable. Calibrates meter using internal 1.00 mW reference or external reference oscillator. Reference Cal Factor settable from 50.0% to 120.0%.</p>
<p>OFFSET</p>	<p>Key pad entry or programmable. Range: -99.99 to +99.99 dB in 0.01 dB increments.</p>
<p>Digital Filter Length</p>	<p>Keypad entry or programmable. Averages power readings from 1 to 512 successive values in increments by factors of 2 (1, 2, 4, ... 256, 512).</p>
<p>High/Low Power Limits</p>	<p>Programmable only. Activates Service Request and flashing front panel indicator. Individual channel values from -299.99 to +299.99 dBm in 0.001 dB increments.</p>
<p>STORE/RECALL Registers</p>	<p>Nineteen registers to store complete operating state of meter for later recall.</p>
<p>REL</p>	<p>Key pad entry or programmable. Displays all successive measurements relative to the last displayed value when activated. Units are in dB or %.</p>

Table 1-3. Additional Supplemental Characteristics

Meter Noise

As a % of full scale, with constant temperature, range 1, measured over a one minute interval, and two standard deviations.

Sensors:

HP 8481A, 8481B, 8481H, 8482A, 8482B, 8482H, 8483A, 8485A:

Filter Number	Noise (%)
0	6.0
1	2.4
2	1.8
3	0.9
4	0.7
5	0.5
6	0.4
7	0.3
8	0.2
9	0.15

Sensors:

HP 8484A:

Multiply noise levels by 4 for all filters. Decrease noise by a factor of 10 for each higher range for all sensors and all filters.

Settling Time

0 to 99% settled readings over the bus. AUTO filter, range hold, 10 dB decreasing power step.

Single channel

Range	Settling Time
1	<3.0 s
2	<1.0 s
3	<150 ms
4-5	<100 ms

Manual filter, range hold, 10 dB decreasing power step.

Single channel

Filter Number	Response Time(s)
0	0.10
1	0.15
2	0.25
3	1.0
4	1.4
5	2.2
6	3.7
7	6.9
8	14.0
9	27.0

Dual channel (ratio or difference mode):

Approximately the sum of the individual response times of each channel, plus channel switching delay.

Table 1-4. Recommended Test Equipment

Instrument	Critical Specifications	Recommended Model	Use ¹
Digital Voltmeter	Range 0 to 20 Vdc Resolution: 0.01 Volt	HP 3456A	P, A, T
Oscilloscope	>200 MHz bandwidth	HP 1725A	T
Range Calibrator	Calibration uncertainty $\pm 0.25\%$	HP 11683A	P, A, T
Signature Multimeter	Qualified Signiture Analysis	HP 5005B	T
Frequency Counter	Range: 10 Hz to 50 MHz Resolution: 1 Hz	HP 5328A Option 031	P, A, T
Power Splitter	Frequency: 50 Mhz Impedance: 50 Ohms Connectors: Type N	HP 11667A	O
Power Meter	Range: 1 mW Transfer Accuracy: 0.2% (Input to output)	HP 432A	P, A, T
Thermistor Mount	SWR: 1.05 at 50 MHz Accuracy: $\pm 0.5\%$ at 50 MHz	HP 478A-H75 HP 478A-H76 ²	P, A

¹ *P=Performance Tests, A=Adjustments, T=Troubleshooting.

² Calibrated by the National Institute of Standards and Technology (NIST) for this accuracy.

Table 1-5. Service Accessories

Accessory ¹	Specification	Suggested Model
Open-end wrench (SMC connectors)	1/4-inch	Utica Tool Co. ² , Open End Standard, Model No. OP82, 1/4-inch
Extender Board	36 contacts (2 x 18)	HP 08684-60018
Foam Pad	Conductive polyurethane foam, 12 x 12 x 0.25 inches	HP 4208-0094

¹ Refer to section 8, "Service" for applications.

² Utica Tool Company, Inc. Orangeburg, SC 29115 or the nearest Utica Tool Company distributor.



Installation

2-1. Introduction

This section provides the information needed to install the power meter. Included is information pertinent to the initial inspection, power requirements, line voltage and fuse selection, operating environment, instrument mounting, storage, and shipment.

2-2. Initial Inspection

Warning



To avoid hazardous electrical shock, do not perform electrical tests when there are signs of shipping damage to any portion of the outer enclosure (covers, panels and display).

Inspect the shipping container for damage. If the shipping container or cushioning material is damaged, it should be kept until the contents of the shipment have been checked for completeness and the instrument has been checked mechanically and electrically. The procedures for checking electrical performance are given in section 4, "Performance Tests". If the contents are incomplete, if there is a mechanical defect, or if the instrument does not pass the performance tests, notify the nearest Hewlett-Packard office. If the shipping container is damaged or the cushioning shows signs of stress, notify the carrier and the Hewlett-Packard office. Keep the shipping material for the carrier's inspection.

2-3. Preparation for Use

Warning



2-4. Power Requirements

To avoid the possibility of hazardous electrical shock, do not operate this instrument at line voltages greater than 126.5 Vac with line frequencies greater than 66 Hz. Leakage currents at these settings may exceed 3.5 mA.

This is a Safety Class I product (that is, it is provided with a protective earth terminal). An uninterruptible safety earth ground must be provided from the main power source to the product input wiring terminals through the power cable set or supplied power cord set. Whenever it is likely that the protection has been impaired, the instrument must be made inoperative and secured against any unintended operation.

If this instrument is to be energized via an external autotransformer (for voltage reduction), make sure the common terminal is connected to neutral (that is, the grounded side of the line (Mains) supply).

The power meter requires a power source of any voltage between 90 and 126 Vac or between 198 and 252 Vac, 48 to 66 Hz, single phase. The power meter has the additional capability of operating with line frequencies of 360 to 440 Hz. However, operation at line frequencies greater than 66 Hz is limited to a line voltage of 90 to 126 Vac. The power consumption is less than 65 VA using either source.

2-5. Installation Checklist

Before plugging the power meter into the line (Mains) voltage, ensure the following steps are taken:

1. Check the line (Mains) voltage to ensure compatibility with the power meter requirements. (See paragraph “2-4. Power Requirements”).
2. Check the line voltage switches on the power meter’s rear panel to ensure proper selection for the line (Mains) voltage. (See paragraph “2-6. Line Voltage and Fuse Selection”).
3. Ensure that the fuse rating is appropriate for the line voltage used. Fuse ratings are listed in Table 2-1.
4. Ensure that the power cable to be used is the required type. (See paragraph “2-7. Power Cable”).

Caution



BEFORE PLUGGING THIS INSTRUMENT into the line (Mains) voltage, ensure that the correct voltage and fuse have been selected.

5. Plug in the power cable.

2-6. Line Voltage and Fuse Selection

Caution



BEFORE PLUGGING THIS INSTRUMENT into the Mains (line) voltage, be sure that the correct operating voltage and fuse have been selected.

A rear-panel line-power module permits operation from 90 to 126 Vac sources or from 198 to 252 Vac sources. The number visible in the window on the module indicates the nominal line voltage (100, 120, 220 or 240 Vac) to which the instrument must be connected. Verify that the line voltage selection card and the fuse are matched to the power source to be used. Refer to Figure 2-1, Line Voltage and Fuse Selection. Table 2-1 lists the ratings and HP part numbers for the replaceable fuses.

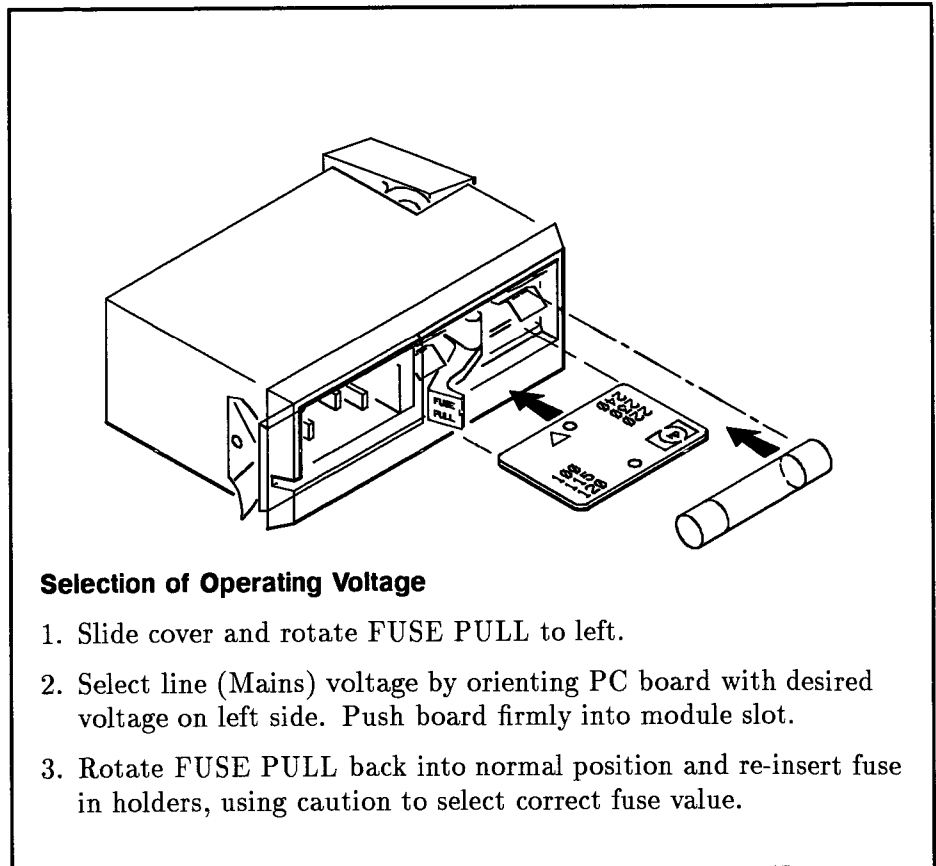

Figure 2-1. Line Voltage and Fuse Selection

Warning

For protection against fire hazards, the line fuse should be a 250V normal-blow fuse with the correct current rating.

Table 2-1. Fuse Ratings and Part Numbers

Line Voltage	Rating	Part Number
100/120V	1.0A, 250 V	2110-0001
220/240V	0.375 A, 250 V	2110-0421

2-7. Power Cable**Warning**

Before connecting this instrument, the protective earth terminal of the instrument must be connected to the protective conductor of the (Mains) power cord. The Mains plug shall be inserted only in a socket outlet provided with a protective earth contact. The protective action must not be negated by the use of an extension cord (power cable) without a protective conductor (grounding). Grounding one conductor of a two-conductor outlet is not sufficient protection.

This instrument is equipped with a three-wire power cable. When connected to an appropriate ac power receptacle, this cable grounds the instrument cabinet. The type of power cable plug shipped with each instrument is determined by the country of destination. Refer to Figure 2-2 for the part numbers of these power cables. Cables are available in different lengths and some with right angle plugs to the instrument. Check with you nearest HP service center for descriptions and part numbers for these cables.

<p>HP 8120-1351 BS 1363A PLUG</p>  <p>UNITED KINGDOM</p>	<p>HP 8120-1369 NZSS 198/AS 3112 PLUG</p>  <p>AUSTRALIA/NEW ZEALAND</p>	<p>HP 8120-1689 CEE 7 STD SHT VII, DIN 49441, VDE 0620</p>  <p>CONTINENTAL EUROPE</p>
<p>HP 8120-1378 NEMA 5-15P</p>  <p>U. S. /CANADA (NOT INTERCHANGEABLE WITH 8120-4753)</p>	<p>HP 8120-1575 IEC 320-C14</p>  <p>For interconnecting HP FASS system components and peripherals</p>	<p>HP 8120-2104 SEV 1011.1958-24507 TYPE 12 PLUG</p>  <p>SWITZERLAND</p>
<p>HP 8120-2956 DHCR 107 PLUG</p>  <p>DENMARK</p>	<p>HP 8120-4211 IEC 83, STD B1 (SABS 164)</p>  <p>REPUBLIC OF SOUTH AFRICA and INDIA</p>	<p>HP 8120-4753 MITI 41-8692 PLUG</p>  <p>JAPAN (NOT INTERCHANGEABLE WITH 8120-1378)</p>

Figure 2-2. Power Cable and Line (Mains) Plug Part Numbers

2-8. HP-IB Address Selection and Configuring

The address can be selected from the front panel and stored in RAM. When shipped from the factory the address of the instrument is 13.

When an address is stored in RAM and not lost, changing the internal HP-IB switch will have no effect. The address that is stored in RAM can be viewed on the front panel display by pressing **LCL** (local) and will be the valid address unless memory is lost. Memory lost is indicated by a RCL FAIL ERROR message.

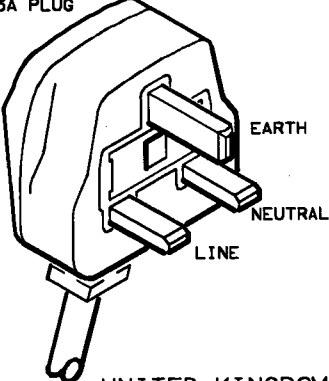
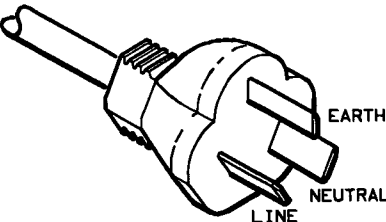
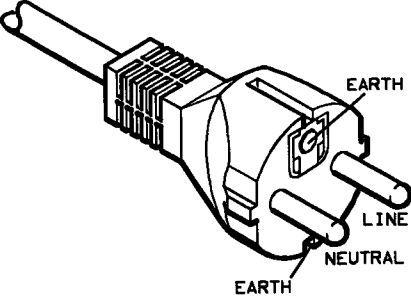
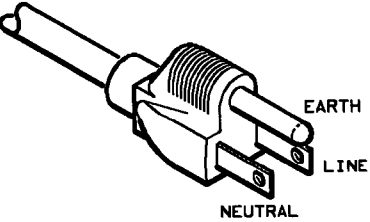
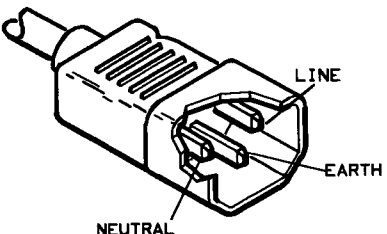
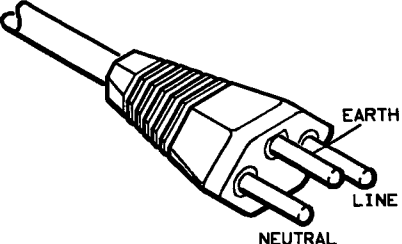
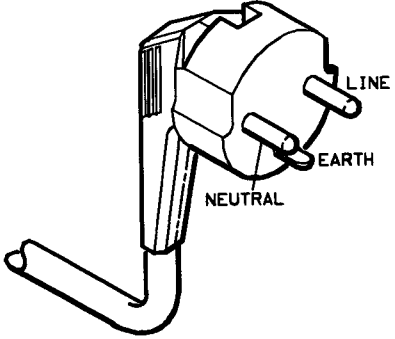
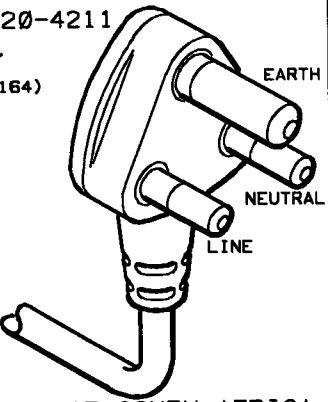
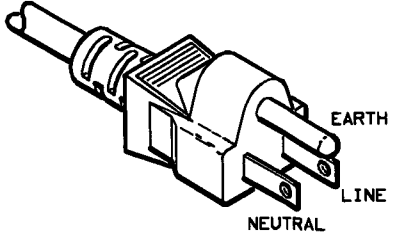
HP-IB addresses from 00 to 30 can be used. A list of allowable addresses is given in Table 2-2. Table 2-2 shows the ASCII address codes to decimal equivalents.

Table 2-2. Allowable HP-IB Addresses

ASCII Address Codes		Decimal Equivalents ¹
LISTEN	TALK	
SP	@	00
!	A	01
,	B	02
-	C	03
\$	D	04
%	E	05
&	F	06
'	G	07
(H	08
)	I	09
*	J	10
+	K	11
,	L	12
-	M	13 ²
.	N	14
/	O	15
0	P	16
1	Q	17
2	R	18
3	S	19
4	T	20
5	U	21
6	V	22
7	W	23
8	X	24
9	Y	25
:	Z	26
;	[27
<	}	28
=]	29
>		30

¹ Decimal values are equivalent to the last five bits of both talk and listen addresses.

² Decimal 13 is the factory set HP 437b address.

Use the following procedure to set the HP-IB address:

1. Turn the instrument off.
2. Press and hold the **LCL** (local) key while turning the instrument on.
3. Wait for the Ent (enter) address message.
4. Release the **LCL** key.
5. Key in the address using the keys representing the numbers.

2-9. Interconnections

The connection from meter to power sensor is made through HP 11730 series sensor cables having circular 12 contact male mating connectors. The two front panel connectors (Sensor A and Sensor B), and the two rear panel Option 002 connectors (SENSORS A,B) require this mating connector.

The rear panel interface connector for the Hewlett Packard Interface Bus is a 24 pin connector. The HP-IB mating connector is shown in Figure 2-3. Part numbers for mating connectors are included in the figure. Note the two securing screws are metric.

2-10. Mating Connectors

Coaxial Connectors. The front-panel output POWER REF 1.00mW 50 MHz and the rear-panel Option 002 OSC (power reference oscillator) output connectors require 50-ohm type N male mating connectors. The rear panel RCDR (recorder) output signal connector requires a 50-ohm BNC male mating connector. Both types must be compatible with the specifications of US MIL-C-39012. The power reference oscillator connectors are designed to be used with power sensors that have Type N connectors.

2-11. Operating Environment

The operating environment is specified to be within the following limitations:

- Temperature 0°C to +55°C
- Humidity <95% relative
- Altitude <4570 metres (15 000 feet)

2-12. Bench Operation

The instrument cabinet has plastic feet and fold-away tilt stands for convenience in bench operation. The plastic feet are designed to ensure proper stacking with other instruments in similar housings, and the tilt stands raise the front of the power meter for easier viewing of the front panel.

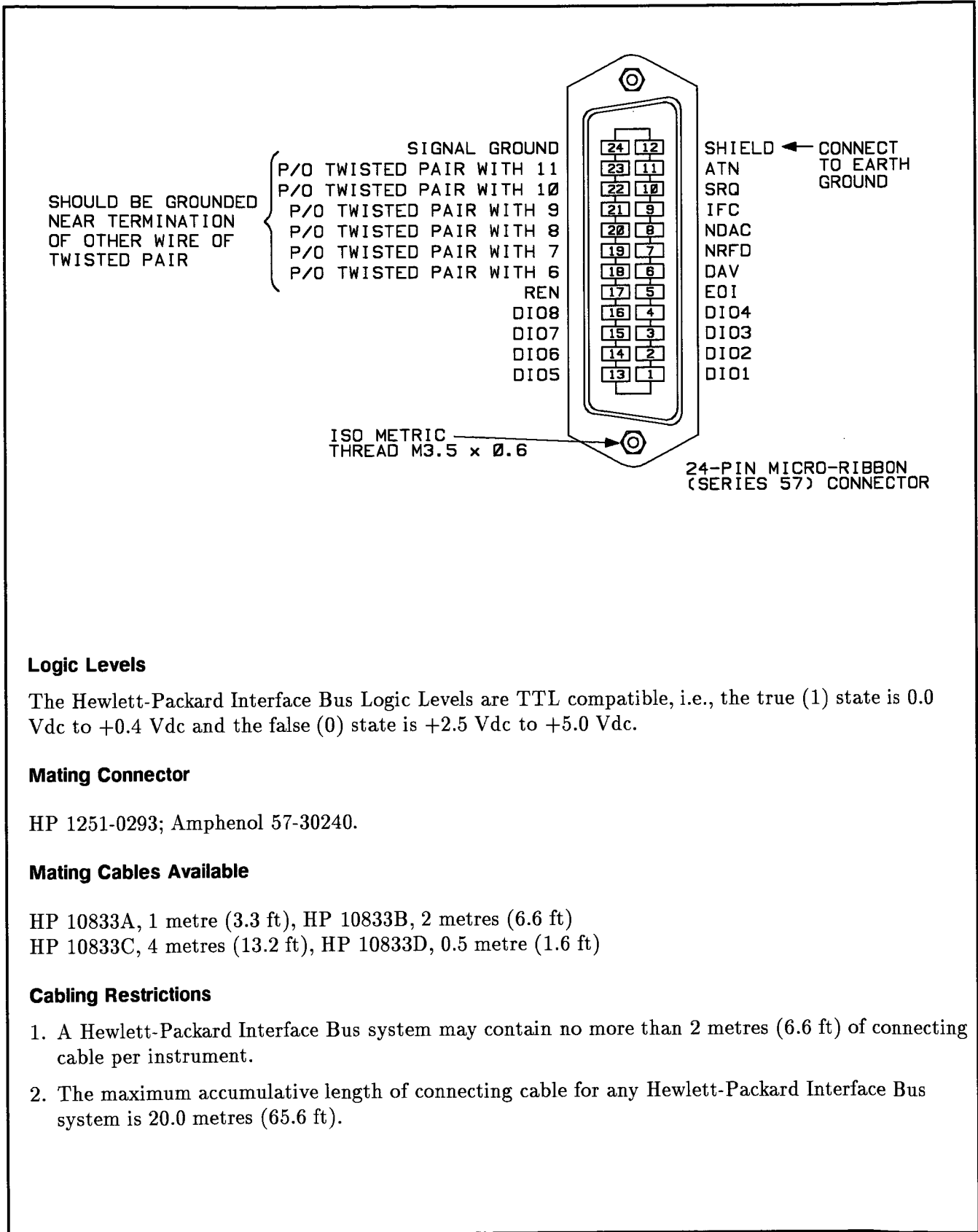

Logic Levels

The Hewlett-Packard Interface Bus Logic Levels are TTL compatible, i.e., the true (1) state is 0.0 Vdc to +0.4 Vdc and the false (0) state is +2.5 Vdc to +5.0 Vdc.

Mating Connector

HP 1251-0293; Amphenol 57-30240.

Mating Cables Available

HP 10833A, 1 metre (3.3 ft), HP 10833B, 2 metres (6.6 ft)
 HP 10833C, 4 metres (13.2 ft), HP 10833D, 0.5 metre (1.6 ft)

Cabling Restrictions

1. A Hewlett-Packard Interface Bus system may contain no more than 2 metres (6.6 ft) of connecting cable per instrument.
2. The maximum accumulative length of connecting cable for any Hewlett-Packard Interface Bus system is 20.0 metres (65.6 ft).

Figure 2-3. Hewlett-Packard Interface Bus Connection

2-13. Rack Mounting

The power meter may be rack mounted using Hewlett-Packard sub-module cabinets. If it is desired to rack mount one power meter by itself, order half-module kit, HP part number 5062-3972. If it is desired to rack mount two power meters or another HP product with the same physical dimensions, side by side, order the following items:

- 1. Lock Link Kit, HP part number 5062-3994
- 2. Rack Mounting Flange Kit, HP part number 5062-3974

When rack mounting with a support shelf and slide kit order:

- 1. Shelf, HP part number 5062-3996
- 2. Slide Kit, HP part number 1494-0064

In addition to the rack mounting hardware, a front handle assembly (two provided) is also available for the power meter. Order front handle kit Option 907 HP part number 5061-9688.

Rack mounting information is provided with the rack mounting kits. If a kit was not ordered as an option or an accessory with the power meter, it may be purchased through the nearest Hewlett-Packard office. Refer to "Mechanical Options" or "Mechanical Equipment Available" in section 1.

2-14. Storage and Shipment

2-15. Environment

The instrument should be stored in a clean, dry environment. The following environmental limitations apply to both storage and shipment.

- Temperature -55° to +75°C
- Humidity <95% relative
- Altitude <15 300 metres (50 000 feet)

2-16. Packaging

Tagging for Service. If the instrument is being returned to Hewlett-Packard for service, please complete one of the blue repair tags located at the end of this manual and attach it to the instrument.

To minimize repair time, be as specific as possible when describing the failure. Keep the following two items in mind when describing the failure:

1. Describe what makes you think the instrument is failing. An example might be "Power meter displays NO SENSOR when a power sensor is connected to the input port".
2. If the failure only occurs under certain conditions, explain how to duplicate the failure. An example might be "Power meter will not make measurements in ranges 4 and 5."

Original Packaging. Containers and materials identical to those used in factory packaging are available through Hewlett-Packard offices. Mark the container "FRAGILE" to encourage careful handling. In any correspondence, refer to the instrument by model number and full serial number.

Other Packaging. The following general instructions should be used for repackaging with commercially available materials.

1. Wrap the instrument in heavy paper or plastic. If shipping to a Hewlett-Packard office or service center, complete one of the blue tags mentioned above and attach it to the instrument.
2. Use a strong shipping container. A double-wall carton made of 2.4 MPa (350 psi) test material is adequate.
3. Use enough shock-absorbing material (75 to 100 mm layer; 3 to 4 inches) around all sides of the instrument to provide a firm cushion and prevent movement in the container. Protect the front panel with an appropriate type of cushioning material to prevent damage during shipment.
4. Seal the shipping container securely.
5. Mark the shipping container "FRAGILE" to encourage careful handling.

Operation

3-1. Introduction

This section provides operating information for the power meter. Included in this section are general and detailed operating instructions, descriptions of the front and rear panel, local and remote operator's instructions, and operator's maintenance procedures.

3-2. Operating Characteristics

Table 3-1 briefly summarizes the major operating characteristics of the power meter. This table is not intended to be an in-depth listing of all operations and ranges but gives an idea of the instrument's capabilities. For more information on the power meter's capabilities refer to Table 1-1, Specifications and Table 1-2, Supplemental Characteristics. For information on HP-IB capabilities, refer to the summary contained in Table 3-3, HP-IB Message Reference Table.

3-3. Local Operation

Initial Turn-On Information Instructions relating to the power meter's turn-on procedure are presented to acquaint the user with the general operation of the instrument.

Information covering front panel operation of the power meter is given in the sections described below. To rapidly learn the operation of the instrument, begin with Major Operating Characteristics and Operator's Checks.

Panel Features Front and rear panel features are described in Figure 3-1 and Figure 3-2. The front panel has different colored keys and lettering for different operating modes. The **SHIFT** key has yellow lettering and relates to the shifted capability of the **A**, **B**, and **B/A** keys as shown by the yellow lettering next to these keys. Blue keys, blue numbers and all blue lettering are related and set the power meter into its entry mode. When a blue key is pressed the display will show that a Ent (enter) response is required. Also some of the keys have a two letter mnemonic near them. This two letter mnemonic will be used in remote programming of the power meter.

Simplified Operating Instructions The instructions located on the foldout provide a quick introduction to front panel operation of the power meter. These instructions are designed to rapidly acquaint the new user with basic operating procedures and therefore are not an exhaustive listing of all power meter functions.

Detailed Operating Instructions The detailed operating instructions provide the operating reference information for the power meter user.

3-4. Remote Operation HP-IB

The power meter is capable of remote operation via the Hewlett-Packard Interface Bus (HP-IB). Instructions pertinent to HP-IB operation cover considerations and instructions specific to remote operation including capabilities, addressing, input and output formats, the status byte, and service requests. At the end of the discussion is a complete summary of all codes.

3-5. Operator's Maintenance

Warning



For continued protection against fire hazard, replace the line fuse with a 250V fuse of the same rating only. Do not use repaired fuses or short-circuited fuseholders.

Operator's maintenance consists of replacing defective fuses. The primary power fuse is located within the line Power Module Assembly. Refer to Figure 2-1 for instructions on how to change the fuse.

If the instrument does not operate properly and is being returned to Hewlett-Packard for service, please complete one of the blue tags located at the end of this manual and attach it to the instrument. Refer to section 2 for packaging instructions.

Table 3-1. Major Operating Characteristics

<p>Power Range (Sensor Dependant)</p>	<p>-70 dBm to +44 dBm Auto or Manual 1 through 5 ranges, the power range of each sensor is divided into five parts.</p> <table border="0"> <thead> <tr> <th style="text-align: left;">Power Sensor</th> <th style="text-align: left;">Range</th> </tr> </thead> <tbody> <tr> <td>HP8481B</td> <td>0 to +44 dBm (1 mW to 25 W)</td> </tr> <tr> <td>HP8482B</td> <td>0 to +44 dBm (1 mW to 25 W)</td> </tr> <tr> <td>HP8481H</td> <td>-10 to +35 dBm (100 μW to 3 W)</td> </tr> <tr> <td>HP8482H</td> <td>-10 to +35 dBm (100 μW to 3 W)</td> </tr> <tr> <td>HP8481A</td> <td>-30 to +20 dBm (1 μW to 100 mW)</td> </tr> <tr> <td>HP8482A</td> <td>-30 to +20 dBm (1 μW to 100 mW)</td> </tr> <tr> <td>HP8485A</td> <td>-30 to +20 dBm (1 μW to 100 mW)</td> </tr> <tr> <td>HP8483A (75 Ω)¹</td> <td>-30 to +20 dBm (1 μW to 100 mW)</td> </tr> <tr> <td>HP R/Q8486A</td> <td>-30 to +20 dBm (1 μW to 100 mW)</td> </tr> <tr> <td>HP8481D</td> <td>-70 to -20 dBm (100 pW to 10 μW)</td> </tr> <tr> <td>HP8484A</td> <td>-70 to -20 dBm (100 pW to 10 μW)</td> </tr> <tr> <td>HP8485D</td> <td>-70 to -20 dBm (100 pW to 10 μW)</td> </tr> <tr> <td>HP R/Q8486D</td> <td>-70 to -20 dBm (100 pW to 10 μW)</td> </tr> <tr> <td>HP8487D</td> <td>-70 to -20 dBm (100 pW to 10 μW)</td> </tr> </tbody> </table>	Power Sensor	Range	HP8481B	0 to +44 dBm (1 mW to 25 W)	HP8482B	0 to +44 dBm (1 mW to 25 W)	HP8481H	-10 to +35 dBm (100 μ W to 3 W)	HP8482H	-10 to +35 dBm (100 μ W to 3 W)	HP8481A	-30 to +20 dBm (1 μ W to 100 mW)	HP8482A	-30 to +20 dBm (1 μ W to 100 mW)	HP8485A	-30 to +20 dBm (1 μ W to 100 mW)	HP8483A (75 Ω) ¹	-30 to +20 dBm (1 μ W to 100 mW)	HP R/Q8486A	-30 to +20 dBm (1 μ W to 100 mW)	HP8481D	-70 to -20 dBm (100 pW to 10 μ W)	HP8484A	-70 to -20 dBm (100 pW to 10 μ W)	HP8485D	-70 to -20 dBm (100 pW to 10 μ W)	HP R/Q8486D	-70 to -20 dBm (100 pW to 10 μ W)	HP8487D	-70 to -20 dBm (100 pW to 10 μ W)
Power Sensor	Range																														
HP8481B	0 to +44 dBm (1 mW to 25 W)																														
HP8482B	0 to +44 dBm (1 mW to 25 W)																														
HP8481H	-10 to +35 dBm (100 μ W to 3 W)																														
HP8482H	-10 to +35 dBm (100 μ W to 3 W)																														
HP8481A	-30 to +20 dBm (1 μ W to 100 mW)																														
HP8482A	-30 to +20 dBm (1 μ W to 100 mW)																														
HP8485A	-30 to +20 dBm (1 μ W to 100 mW)																														
HP8483A (75 Ω) ¹	-30 to +20 dBm (1 μ W to 100 mW)																														
HP R/Q8486A	-30 to +20 dBm (1 μ W to 100 mW)																														
HP8481D	-70 to -20 dBm (100 pW to 10 μ W)																														
HP8484A	-70 to -20 dBm (100 pW to 10 μ W)																														
HP8485D	-70 to -20 dBm (100 pW to 10 μ W)																														
HP R/Q8486D	-70 to -20 dBm (100 pW to 10 μ W)																														
HP8487D	-70 to -20 dBm (100 pW to 10 μ W)																														
<p>Frequency Range (Sensor Dependent)</p> <p>Zeroing</p> <p>Calibration Factor¹</p> <p>Power Reference</p> <p>Power Display</p> <p>Ratio and Difference</p> <p>Offset</p> <p>Digital Filtering</p> <p>Memory</p>	<p>100 kHz to 33.0 GHz</p> <p>Calibration of the power meter to power sensor sensitivity</p> <p>Compensation for mismatch and effective efficiency</p> <p>1 mW at 50 MHz</p> <p>dBm, dB Relative, Watts, and % Relative</p> <p>Dual Inputs Ratio in dB or % Difference in dBm or Watts</p> <p>Compensation for gains or losses in test system</p> <p>Auto or Manual filters 0 through 9 A filter length or number of readings is determined by two being raised to some power where that exponent is the filter number.</p> <p>19 registers for store and recall of front panel information. A twentieth register is used for recall of power down information .</p>																														

¹ When using an older HP 8483A that specifies adjusting to 0.96 mW note that the following procedure should be used:

1. Set REF CF to 0.96 times the Ref Cal Factor on the label.
2. The power meter will automatically adjust to 1.000 mW. Note that the cal factor value for 50 MHz power measurements should be read for the plotted data on the sensor body. No special procedure is necessary for these measurements.



SIMPLIFIED FRONT PANEL FEATURES

SET A (±)

Sets the power meter into the enter A mode for parameter changes.

SET B (°)

Set the power meter into the enter B mode for parameter changes.

A (A-B)

Selects channel A as the single sensor active channel and initiates the command to put the meter in the display channel A power mode.

B (B-A)

Selects channel B as the single sensor active channel and initiates the command to put the meter in the display channel B power mode.

B/A (B)

Sets the power meter to the double sensor mode and initiates the command to display the ratio of the power readings. The active entry channel is B and the ratio order is B/A.

SHIFT

Enables a shifted function of the A, B, and B/A keys. This allows for ratio (A/B) and the difference of two power levels to be measured.

LINE

Primary power to the meter is switched on and off.

In places where key cap labels are followed by letters or symbols in parentheses the keys have a secondary function to the one in the simplified explanation. When the data entry mode is active the keys are SET A for + and - signs, SET B for the decimal point, various keys for numeric inputs 0 through 9, REL where a calculated offset is displayed DSP - OFS, 1 dbm WATT, when information in the display is entered ENTER, and LCL for cancelling the entry mode CLEAR ENTRY.

CAL FACTOR (2)

The power meter enters the calibration factor entry mode and a cal factor printed on the sensor can be entered.

ZERO (0)

Initiates a routine that zeros the power meter sensor combination.

CAL ADJ (1)

The power meter enters the calibration mode and a reference calibration factor can be entered prior to being calibrated to the 1 mW power reference.

OFFSET (3)

Enters the offset entry mode and the user can enter an offset for the channel selected. The range of offsets is -99.99 to +99.99 db in 0.01 db increments.

MNL FILTER (8)

Numeric entry mode becomes active and the user can now enter a new filter for the selected channel. Filter numbers range from zero through nine.

STORE (4)

Enters the store instrument state numeric entry mode becomes active and the user can enter a storage register location in the range of one to nineteen.

REL (DSP - OFS)

The rel (relative) mode is enabled and power levels relative to some other power level is measured.

dbm WATT (ENTER)

This command toggles the measurement units depending on the user wanting a linear or logarithmic display.

LCL (CLEAR ENTRY)

Returns the power meter to the local mode if not in local lockout from a bus command.

A and B

The inputs to channel A and B are through female 12 contact audio connectors.

RECALL (9)

Information in storage register locations zero through nineteen can be recalled and displayed.

OSC

Turns the power reference oscillator on and off. When Option 002 is installed this key turns both reference oscillators on and off.

AUTO FILTER (7)

The selected channel enters the auto filter mode and one of nine filters is automatically selected.

MNL RANGE (6)

The numeric entry mode becomes active and the user can enter a power range of one through five.

PRESET

The power meter is put into a preset state and the parameters for channel A and B are set to default conditions.

POWER REF

The power reference output is a 50 ohm type N connector and the signal is 1 mW at 50 MHz used for calibrating the sensor meter combination.

AUTO RANGE (5)

Causes the selected channel to enter an auto range mode.

Figure 3-1. Simplified Front Panel Features

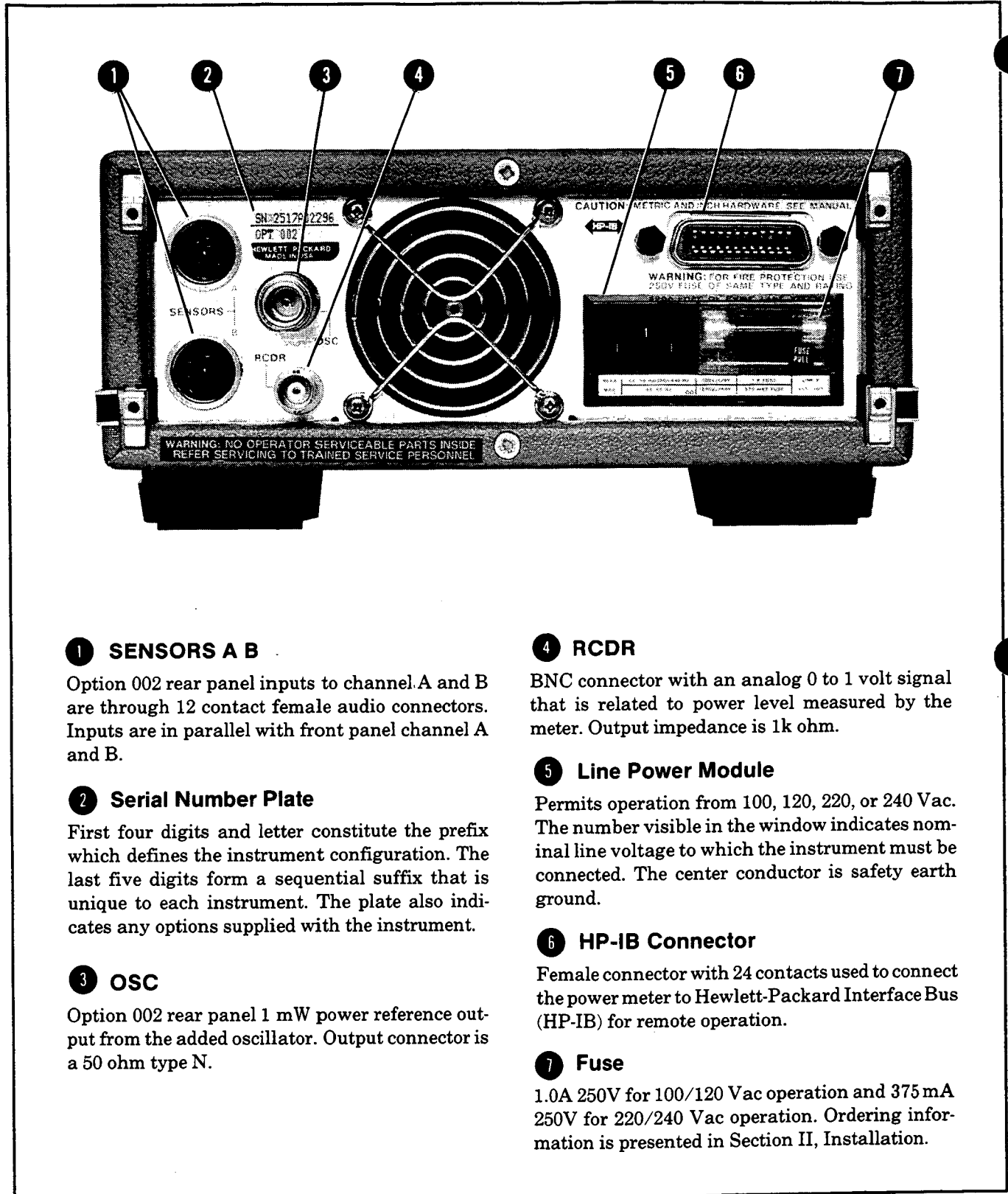

1 SENSORS A B

Option 002 rear panel inputs to channel A and B are through 12 contact female audio connectors. Inputs are in parallel with front panel channel A and B.

2 Serial Number Plate

First four digits and letter constitute the prefix which defines the instrument configuration. The last five digits form a sequential suffix that is unique to each instrument. The plate also indicates any options supplied with the instrument.

3 OSC

Option 002 rear panel 1 mW power reference output from the added oscillator. Output connector is a 50 ohm type N.

4 RCDR

BNC connector with an analog 0 to 1 volt signal that is related to power level measured by the meter. Output impedance is 1k ohm.

5 Line Power Module

Permits operation from 100, 120, 220, or 240 Vac. The number visible in the window indicates nominal line voltage to which the instrument must be connected. The center conductor is safety earth ground.

6 HP-IB Connector

Female connector with 24 contacts used to connect the power meter to Hewlett-Packard Interface Bus (HP-IB) for remote operation.

7 Fuse

1.0A 250V for 100/120 Vac operation and 375 mA 250V for 220/240 Vac operation. Ordering information is presented in Section II, Installation.

Figure 3-2. Rear Panel Features

PRESET

Press **PRESET** to set the Power Meter to the following conditions:

Measurement Mode = Sensor A
 Reference Oscillator = Off
 Active Entry Channel = A
 Measurement Units = Watts
 REL Mode = Off
 Measurement Parameters (set for Sensor A and Sensor B)
 Cal Factor = 100.0%
 Cal Adj = 100.0%
 Offset = 0.00 dB
 Auto Filter
 Auto Range

In addition, default conditions are set for some remote-only functions. Refer to Table 3-5, Response to Clear Message (and PRESET).

CALIBRATION

Connect the power sensor as shown.

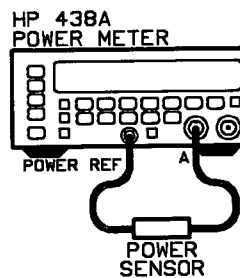

Press **ZERO** to zero the Power Meter. Each sensor must be zeroed separately for dual sensor operation.

CAL ADJ is used only during calibration for entering the sensor's calibration factor at 50 MHz (that is, the reference calibration factor). For example, to calibrate the Power Meter to the sensor with a reference cal factor of 98%, press **CAL/ADJ** **RECALL** **MNL/FILTER** **dBm/WATT**

MEASUREMENT MODES

The Power Meter can display single sensor (A or B), dual sensor ratio (A/B or B/A) or dual sensor difference (A-B or B-A) power measurements. In addition, measurements can be displayed relative to a reference measurement.

SENSOR

To display the Sensor A power measurement on the front panel, press **A**.

Single sensor measurements are display in dBm or Watts.

To display the ratio of Sensor A divided by Sensor B, press **SHIFT** **A/B** **B/A**.

Ratio measurements are displayed in dB or %.

To display the difference between Sensor A and Sensor B, press **SHIFT** A-B **A**.

Difference measurements are displayed in dBm or Watts.

REL

Press **REL** to enter and exit relative mode.

Once relative mode has been entered, the first power reading is saved as a reference. Successive measurements are displayed relative to the reference.

The REL annunciator in the front panel display lights when the Power Meter is in relative mode.

MEASUREMENT PARAMETERS

Measurement parameter can be set for each sensor. Blue keys indicate parameters that have selectable values. Values are selected in a Blue Key-Data-ENTER format. Data consists of digits 0 through 9, \pm , and the decimal point. Pressing any blue key activates the data functions of the corresponding keys.

SET A and SET B

SET A and SET B allow measurement parameters to be entered for Sensor A and Sensor B. For example, to designate channel A as the active entry channel, press SET A **□**.

Any measurement parameters that are entered will apply to Sensor A only, regardless of the measurement mode displayed on the front panel.

CAL FACTOR

The calibration factor is the frequency response of the sensor relative to 50 MHz. For example, to enter a calibration factor of 100%, press **CAL/FACTOR** **CAL/ADJ** **ZERO** **ZERO** **dBm/WATT**.

FILTER

A digital filter averages measurement readings to reduced jitter. A filter number (0 through 9) is entered to set the filter length. The filter length is the number of readings averaged and is equal to 2 to the power of the filter number (that is, from 1 to 512 in powers of 2).

AUTO/FILTER selects the optimum filter length automatically.

Because of speed, resolution, and display considerations, the filter can be set manually. Measurements with higher filter numbers are slower and more settled; measurements with lower filter numbers are faster and have more jitter. For example, to manually set the filter to 7 (filter length of 128), press **MNL/FILTER** **AUTO/FILTER** **dBm/WATT**

RANGE

The Power Meter divides the sensor's power range into five ranges of 10 dB each. Range 5 may be less than 10 dB if the sensor has a power range of less than 50 dB. Range 1 is the most sensitive, and range 5 is the least sensitive.

AUTO/RANGE sets the correct range automatically for the current measurement.

Manual range is used primarily with the rear panel recorder output or when faster readings are required. For example, to set range manually to Range 3, press **MNL/RANGE** **OFFSET** **dBm/WATT**.

OFFSET

Offsets can be added to measurements to compensate for gain or loss in the measurement system. For example, to add an offset of 20 dB, press

OFFSET **CAL/FACTOR** **ZERO** **dBm/WATT**

MEASUREMENT UNITS

Single sensor and difference measurements are displayed in units of Watts or dBm. Ratio and relative measurements are displayed in either percent of dB. Press **dBm/WATT** to toggle from one measurement unit to another.

STORE and RECALL

The Power Meter can store up to 19 instrument configurations for recall at a later time. For example, to store an instrument configuration in storage register 10, press **STORE** **CAL/ADJ** **ZERO** **dBm/WATT**

RECALL **OFFSET** **dBm/WATT** recalls an instrument configuration stored in register 3 and changes the Power Meter to the recalled parameters.

3-6. Turn-On Instructions

Warning

Before the instrument is switched on, all protective earth terminals, extension cords, autotransformers and devices connected to it should be connected to a protective earth grounded socket. Any interruption of the protective earth grounding will cause a potential shock hazard that could result in personal injury.

Only 250V normal blow fuses with the required rated current should be used. Do not use repaired fuses or short circuited fuseholders. To do so could cause a shock or fire hazard.

Caution

Before the instrument is switched on, it must be set to the voltage of the power source or damage to the instrument may result.

3-7. Turn-On

Turn-On Procedure If the power meter is already plugged in, set the LINE switch to ON.

If the power cable is not plugged in, follow these instructions.

On the rear panel:

1. Check the line voltage switch for correct voltage selection.
2. Check that the fuse rating is appropriate for the line voltage used (see Figure 2-1). Fuse ratings are printed on the rear panel.
3. Plug in the power cable.

On the front panel, press the LINE switch to ON.

Note

Turn-On Configuration. The power meter turns on to the same control settings it had before line power was removed. An exception to this is that it always turns on in the local mode. In addition some HP-IB default conditions are enabled. Refer to "Turn on Default Conditions" later in this section.

When the power meter is turned on, it will execute a power up sequence which will be followed by an automatic RECALL 0. The power up sequence will run some self test routines to verify the operation of ROM, RAM, and display circuits. If any self test failures occur an error message will be reported to the user on the front panel display. If, for some reason, RAM content was lost this error will be reported and all storage registers initialized to put the power meter into the PRESET state. Storage location 0 is also set to the PRESET state when a RAM error occurs. This means the power meter will be in the PRESET state when it begins operation. The internal HP-IB address switch is read only when the memory content is lost. In all other cases the HP-IB address that is entered from the front panel is the one saved in RAM.

Note



An internal battery is used to retain data in RAM during off periods. The data restores the last control setup that was saved in storage location zero and the other nineteen storage registers.

3-8. Error Messages

Power up error message numbers as well as other error messages displayed on the front panel are listed and explained in Table 3-8, Error Messages. As an example, if a ROM or RAM failure occurs, the power meter will display an error code number in the range of 61 through 66 depending on the location in memory that has a problem.

3-9. Power Reference and Calibration

A POWER REF of 1.00 mW at 50 MHz (factory set at $\pm 0.7\%$ and traceable to the National Institute of Standards and Technology (NIST)) is available at the front panel for calibrating the power meter to the sensor.

Note



There are two buttons on the front panel dealing with calibration: **CAL ADJ** and **CAL FACTOR**. **CAL ADJ** is pressed when entering the reference calibration factor for your power sensor and should not need to be reset until another sensor is used. **CAL FACTOR** is pressed when frequency changes. To verify calibration on the power meter front panel, **CAL ADJ** and **CAL FACTOR** must be the same value.

Procedure

The Calibration Procedure which may appear on the power sensor label does not apply to the HP 438A Power Meter.

Some sensors come with attenuators which may or may not need to be connected for calibration.

Power Sensor	Attenuator
HP 8481B	disconnected
HP 8482B	disconnected
HP 8481D	connected
HP 8484A	(HP 11708A) connected
HP 8485D	connected
HP R/Q8486D	connected
HP 8487D	connected

1. To calibrate the power sensor to the meter, first connect the sensor to the POWER REF output. To see if your sensor requires an attenuator for calibration see the list above.
2. Press the **ZERO** key and wait for the zeroing routine to finish.
3. Press **CAL ADJ** and enter the reference calibration factor (Ref. CF) which is printed on the sensor label. (If you have a power sensor that does not specify the reference calibration factor, assume it to be 100%)
4. Press **ENTER** and wait for the calibration routine to finish. The sensor is now calibrated.

5. To see the results of the calibration, first make sure the OSC light is on, then press **CAL FACTOR** and enter the same reference calibration factor (Ref. CF) that you entered for CAL ADJ.

Press **ENTER**. The display should now read 1 mW (0 dBm), except for the following sensors:

Power Sensor	Display
HP 8481B	1 W
HP 8482B	1 W
HP 8481D	1 μ W
HP 8484A	1 μ W
HP 8485D	1 μ W
HP R/Q8486D	1 μ W
HP 8487D	1 μ W

3-10. Operator's Checks

Operator's Checks are procedures designed to verify the proper operation of the power meter's main capabilities. Two procedures are provided as described below.

Basic Functional Checks

This procedure requires power sensors, cables, and a power splitter. It assures the operator that most front panel controlled features are being properly executed by the power meter.

HP-IB Functional Checks

These procedures require an HP-IB compatible computing controller, an HP-IB interface, and connecting cable. The procedures check the applicable bus messages summarized in Table 3-2. The HP-IB Checks assume that front panel operation has been verified by performing the Basic Front Panel Checks.

3-11. Basic Functional Checks

The functions of the power meter are checked using power sensors, sensor cables, and a power splitter. These checks provide reasonable assurance that most of the front panel controlled functions are being executed by the power meter.

Equipment	Power Sensors (2)	HP 8480 Series
	Sensor Cables (2)	HP 11730 Series
	Power Splitter	HP 11667A
	Adapter N(m) to N(m)	HP 1250-1528
	Adapter APC-3.5(f) to N(m)	HP 1250-1744

Procedure The following procedure was developed using power sensors HP 8485A and HP 8481A. Using other sensors such as the HP 8481B will result in different displays.

Turn on the power meter and observe the power up routine with no power sensor connected to the inputs. During power up the diagnostics stored in ROM are executed under microprocessor control and turn on all the display segments and annunciators. This is followed by a shorter flash of all dashes.

When the self-test is finished, the power meter will display no CH A or B, WATT A or B, Error 31 or 32, and flashing A or B. Since the power meter stores the last active parameters in storage location 0 this stored information is what will be recalled and displayed during power up. This is the reason for the "A" or "B" information being displayed.

1. Verify that the power up internal diagnostics are exercised without any error messages other than no CH A, ERROR 31 or no CH B, ERROR 32 depending on which channel was active during power down.
2. Press **PRESET**. This sets the parameters for channel A and B to:
 - Cal Factor = 100.0%
 - Offset = 0.00 dB
 - Low Limit = 0.00 dB
 - High Limit = 0.00 dB
 - Auto Filter
 - Auto Range

3. Set the power meter to the following conditions:

- Measurement Mode..... Sensor A
- Reference Oscillator OFF
- Active Entry Channel A
- Measurement Units Watt
- Limits Checking OFF
- Rel Mode.....OFF
- Group Execute Trigger Mode Trigger with Delay (GT2)
- Trigger Mode Free Run

4. Connect a power sensor with associated cable to channel A input as shown in Figure 3-3. The error message should disappear and display will show either a power level, or **PLEASE 0**, and Error 15. Annunciators **WATT A**, **100% CF**, and **A** on.
5. Connect the power sensor to 1 mW **POWER REF**. Display will show a power level.

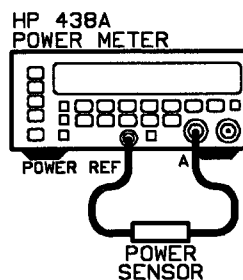

Figure 3-3. Front Panel Checks Setup (1)

6. Press **ZERO**. Wait approximately 15 seconds for the zeroing routine to finish. Verify that display shows **-----**, with a walking decimal point. Observe that the **POWER REF OSC LED** is off during this routine.
7. Press **CAL ADJ**. The power meter will display **Ent -----**, and annunciators **%**, **100.0% CF A**, and **rcF** are on. Enter the **REF CAL FACTOR** shown on the power sensor using blue numeric keys and the **SET B** key for a decimal point.
- Press **ENTER**. The power meter will display **-----**, with a walking decimal point and annunciators **A**, **A**. Wait approximately 5 seconds for the **CAL ADJ** routine. Observe that during **CAL ADJ** the **POWER REF OSC LED** will be turned off and on.
8. Press **CAL FACTOR**. The power meter will display **Ent -----**, **%**, **100.0% CF A**, and **1-150**. Enter the **CAL FACTOR** at 50 MHz. Press **ENTER**. The **CF** displayed will be the one used in the measurements.
9. Turn on **POWER REF OSC**. The display will now read **1.0000 -3**, with annunciators **WATT**, **A**, **100.0% CF**, and **A** on.
10. Press **dBm WATT**. Display will change to **0.00 dBm**.

11. Press **[B]**. Repeat steps 4 through 10 for channel B inputs.
12. Remove sensor from POWER REF OSC. Connect the equipment as shown in FIGURE 3-4.
13. The power meter will display a power level. Annunciators WATT B, 100.0% CF and B are on.
14. Press **[dBm WATT]** to display dBm. The power meter will now display the loss through the power splitter. This number will be used as an offset to get the power level displayed back to 1 mW. Annunciators B, MNL, 100.0% CF, and B are on.
15. Press **[OFFSET]**. The power meter display reads Ent - - - - -, annunciators show dB, 0.00 B, and ≤ 99.99 .

Key in a number equivalent to power loss through power splitter using the blue keys representing the numbers and the **[SET B]** key for the decimal point. Press **[ENTER]**.

An alternative is to just press **[REL]** which is **[DSP→OFS]** in the blue key mode. This takes the loss in dB through the splitter and uses it as the offset to return to a display of 1 mW.

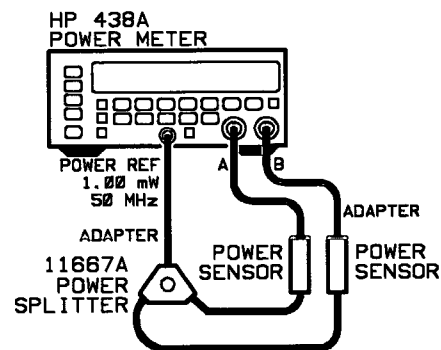

Figure 3-4. Front Panel Checks Setup (2)

16. Press **[A]** to return to channel A as the active channel. Repeat step 15 for channel A.
17. Press **[B/A]**. Press **[dBm WATT]** to display the ratio in %.
18. The above checks have been using the AUTO RANGE and AUTO FILTER modes.

To check the two MNL (manual) keys for RANGE and the FILTER:

Press **[MNL RANGE]**. The power meter will display Ent -.

Annunciators rng 3, 1-5, and A will be on for channel A.

Annunciators rng 1,1-5, and B will be on for channel B.

Press **[MNL FILTER]**. The power meter will display Ent -

Annunciators FLt 1, 0-9, and A will be on for channel A.

Annunciators FLt 7, 0-9, and B will be on for channel B.

19. Observe the **rng** and **FLt** number difference because of the sensor being used.

Note

Several combinations of keys can be exercised at this time to further familiarize yourself with the front panel operation.

3-12. HP-IB Checks

Description

These procedures check the power meter's ability to process or send the HP-IB messages described in Table 3-2. Only the power meter, a power sensor, a controller, and an HP-IB interface are needed to perform these checks.

These procedures do not check that all the power meter program codes are being properly interpreted and executed by the instrument. However, if the power-up sequence and front panel operation are good, the program codes, in all likelihood, will be correctly implemented.

The validity of these checks is based on the following assumptions:

1. The power meter performs properly when operated via the front panel keys (that is, in local mode). This can be verified by the "Basic Functional Checks" in this section.
2. The bus controller properly executes HP-IB operations.
3. The bus controller's interface properly executes the HP-IB operations.

If the power meter appears to fail any of these HP-IB checks, the validity of the above assumptions should be confirmed before attempting to service the instrument.

The select code of the controller's HP-IB interface is assumed to be 7. The address of the power meter is assumed to be 13 (its address set at the factory). This particular select code-address combination (that is, 713) is not necessary for these checks to be valid. However, the program lines presented here must be modified for any other combination.

These checks can be performed together or separately. Any special requirements for a check are described at the beginning of the check.

Initial Setup

The test setup is the same for all of the checks. Connect the equipment as shown in Figure 3-5.

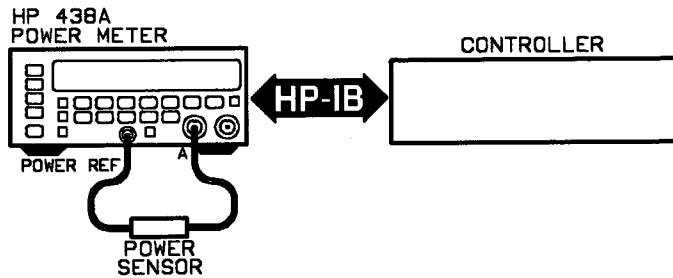

Figure 3-5. HP-IB Functional Checks Setup

Equipment

- HP-IB Controller HP 9000 Series 200/300 (BASIC 2.0)
- Power Sensor HP 848x series

Remote and Local Messages and LCL

This check determines whether or not the power meter properly switches from local to remote control, from remote to local control, and whether or not **LCL** key returns the instrument to local control.

Before beginning this check, set the LINE switch to OFF, then to ON.

Description	Series 200/300 (BASIC)
Send the Remote message (by setting the Remote Enable bus control line, REN, true and addressing the power meter to listen).	REMOTE 713

Check that the power meter's RMT and LSN annunciators are on.

Description	Series 200/300 (BASIC)
Send the Local message to the power meter	LOCAL 713

Check that the power meter's RMT annunciator is off but its LSN annunciator is on.

Description	Series 200/300 (BASIC)
Send the Remote message to the power meter.	REMOTE 713

Check that both the RMT and LSN annunciators are on. Press **LCL** on the power meter. Check that the RMT annunciator is now off, but that the LSN annunciator remains on.

Sending the Data Message

This check determines whether or not the power meter properly issues Data messages when addressed to talk.

Before beginning this check, set the power meter's LINE switch to OFF, then to ON. Press **LCL**. (If an HP Series 200/300 controller is used, a short program is required to perform this check.)

Description	Series 200/300 (BASIC)
Address the power meter to talk and store its output in variable V.	10 V=0 20 ENTER 713;V
Display the value of V.	30 DISP V 40 END

Check that the power meter's TLK annunciator is on. The controller should display the same value as the one shown in the power meter's display. (Note that the power meter displays data using engineering notation. The controller may display the same value using a different format.)

Receiving the Data Message

This check determines whether or not the power meter properly receives Data messages.

Description	Series 200/300 (BASIC)
Send the first part of the Remote message (enabling the power meter to remote).	REMOTE 7
Address the power meter to listen (completing the Remote message), then send a Data message.	OUTPUT 713; "KB 95 EN"

Check that the power meter's RMT and LSN annunciators are on and that the display indicates the channel A cal factor is set to 95%.

Local Lockout and Clear Lockout/Set Local Messages

This check determines whether or not the power meter properly receives the Local Lockout message, disabling all front panel keys (including **LCL**). This check also determines whether or not the Clear Lockout/Set Local message is properly received and executed by the power meter.

This check assumes the power meter is in remote mode.

Description	Series 200/300 (BASIC)
Send the Local Lockout message.	LOCAL LOCKOUT 7

Check that the RMT annunciator is on. Press the power meter's **LCL** key. The RMT annunciator should remain on.

Description	Series 200/300 (BASIC)
Send the Clear Lockout/Set Local message.	LOCAL 7

Check that the power meter's RMT annunciator is off.

Description	Series 200/300 (BASIC)
Return the power meter to remote mode if the remaining checks in this section are to be performed.	REMOTE 713

Check that the power meter's RMT annunciator is on.

Clear Message

This check determines whether or not the power meter properly responds to the Clear message.

This check assumes that the power meter is in remote mode.

Description	Series 200/300 (BASIC)
Send a Data message to set the cal factor to 98.5%.	OUTPUT 713; "KB 98.5 EN"

Check that the power meter's display indicates the channel A cal factor is set to 98.5%.

Description	Series 200/300 (BASIC)
Send the Clear message (setting the cal factor to 100%).	CLEAR 713

Check that the power meter's display indicates the channel A cal factor is set to 100%.

Abort Message

This check determines whether or not the power meter becomes unaddressed when it receives the Abort message.

This check assumes the power meter is in remote mode.

Description	Series 200/300 (BASIC)
Address the power meter to listen.	OUTPUT 713

Check that the power meter's LSN annunciator is on.

Description	Series 200/300 (BASIC)
Send the Abort message, unaddressing the power meter from listening.	ABORTIO 713

Check that the power meter's LSN annunciator is off.

Status Byte Message

This check determines whether or not the power meter sends the Status Byte message.

Before beginning this check, set the power meter's LINE switch to OFF then to ON and press **LCL**.

Description	Series 200/300 (BASIC)
Place the power meter in serial-poll mode (causing it to send the Status Byte message).	SPOLL(713)

Check that the controller's display reads 0.

Require Service Message

This check determines whether or not the power meter can issue the Require Service message (set the SRQ bus control line true).

This check can be performed in either local or remote mode.

Description	Series 200/300 (BASIC)
Send a Data message to set the Service Request Mask to 4.	OUTPUT 713 USING "2A,B"; "@1",4
Send a Data message containing an entry error. This causes the Require Service message to be sent.	OUTPUT 713; "RM 15 EN"

Check that the power meter's SRQ annunciator is on.

Description	Series 200/300 (BASIC)
Read the binary status of the controller's HP-IB interface and store the data in variable V (in this step, 7 is the interface's select code, and 2 is a status register for bus control lines).	10 V=0 20 STATUS 7,2;V
Display the value of the SRQ bit (in this step, 6 is the SRQ bit for the controller, numbered from 0).	30 DISP "SRQ="; BIT(V,6) 40 END

Check that the SRQ value is 1, indicating that the power meter issued the Require Service message.

Status Bit Message

This check determines whether or not the power meter sends the Status Bit message.

This check can be performed in either local or remote mode. If the power meter's SRQ annunciator is off, perform the first part of the Require Service message check before beginning this check.

Description	Series 200/300 (BASIC)
Configure the power meter to respond to a parallel poll with positive-true logic on HP-IB data line DIO3.	SEND 7;LISTEN 13 CMD 5 SCG 10
Place the power meter in parallel poll mode (causing it to send the Status Bit message).	PPOLL(7)

Check that the SRQ annunciator is on and that the response to the parallel poll is 4, indicating that the power meter issued the Status Bit message.

Description	Series 200/300 (BASIC)
Unconfigure the power meter from responding to a parallel poll.	SEND 7; LISTEN 13 CMD 5 SCG 18
Place the power meter in parallel POLL MODE.	PPOLL(7)

Check that the SRQ annunciator is on and that the response to the parallel poll is 0, indicating that the power meter is no longer configured to respond to a parallel poll. To turn the SRQ annunciator off set the LINE switch to OFF, then to ON.

Trigger Message

This check determines whether or not the power meter responds to a Trigger message.

This check assumes that the power meter is in remote mode.

Description	Series 200/300 (BASIC)
Send a Data message to place the Power Meter in the Trigger Hold mode.	10 OUTPUT 713;"TRO"
Send the Trigger message.	20 TRIGGER 713
Address the power meter to talk and store the data in variable V.	30 V=10 40 ENTER 713;V
Display the value of V.	50 DISP V 60 END

Check that the power meter's RMT and TLK annunciators are on and that the controller displays the same value as the one shown in the power meter's display. (Note that the power meter displays data using engineering notation. The controller may display the same value using a different format.)

Table 3-2. Message Reference Table

HP-IB Message	Applicable	Response	Related Command	Interface Functions ¹
Data	Yes	All power meter operations, (except setting the LINE switch and setting the HP-IB address) and remote-only functions are bus programmable. All measurement results are available to the bus.		AH1, SH1, T5, TE0, L3, LE0
Trigger	Yes	The power meter's response to bus command GET (Group Execute Trigger) can be programmed. The default Condition is Trigger With Delay (GT2). If in remote and addressed to listen, the power meter makes a measurement according to the previously programmed setup.	GET	DT1
Clear	Yes	All HP-IB inputs and outputs are cancelled	DCL, SDC	DC1
Remote	Yes	Remote mode is enabled when the REN bus control line is true. Remote mode is not entered, however, until the first time the power meter is addressed to listen. The front panel RMT annunciator lights when the instrument is actually in remote mode. When entering remote mode, no instrument settings or functions are changed but all front panel keys, except LCL , are disabled.	REN	RL1

¹ Commands, control lines, and interface functions are defined by ANSI/IEEE Standard 488.1. Knowledge of these may not be necessary if your controller's manual describes programming in terms of the twelve messages in the "HP-IB Message" column.

Table 3-2. Message Reference Table (continued)

HP-IB Message	Applicable	Response	Related Command	Interface Functions ¹
Local	Yes	The power meter returns to local mode (front panel control). It responds equally to the Go To Local (GTL) bus command and the front panel LCL key.	GTL	RL1
Local Lockout	Yes	Disables all front panel keys, including LCL . Only the controller can return the power meter to local (front panel) control.	LLO	RL1
Clear Lockout/ Set Local	Yes	The power meter returns to local mode (front panel control). Local Lockout is cleared when the bus control line goes false.	REN	RL1
Pass Control/ Take Control	No	The power meter has no controller capability.		C0
Require Service	Yes	The power meter sets the SRQ bus control line true if one of the following conditions exists and has been enabled (via the Service Request Mask) to send the message for that condition: data ready, cal/zero completed, entry error, measurement error, or over/under limits.	SRQ	SR1

¹ Commands, control lines, and interface functions are defined by ANSI/IEEE Standard 488.1. Knowledge of these may not be necessary if your controller's manual describes programming in terms of the twelve messages in the "HP-IB Message" column.

Table 3-2. Message Reference Table (continued)

HP-IB Message	Applicable	Response	Related Command	Interface Functions ¹
Status Byte	Yes	The power meter responds to a Serial Poll Enable (SPE) bus command by sending an 8-bit byte when addressed to talk. If the instrument is holding the SRQ bus control line true (issuing the Require Service message), bit position 6 in the Status Byte and the bit representing the condition causing the Require Service message to be issued will both be true. The bits in the Status Byte are latched but can be cleared by removing the causing condition and then reading the Status Byte or by receiving the Clear Status (CS) program code.	SPE, SPD	T5
Status Bit	Yes	The power meter responds to a Parallel Poll Enable (PPE) bus command by sending a bit on a controller selected HP-IB data line.	PPE, PPD, PPC, PPU	PP1
Abort	Yes	The power meter stops talking and listening.	IFC	T5, TE0, L3, LE0
Complete HP-IB capability as defined in ANSI/IEEE Standard 488.1 is: SH1, AH1, T5, TE0, L3, LE0, SR1, RL1, PP1, DC1, DT1, C0				

¹ Commands, control lines, and interface functions are defined by ANSI/IEEE Standard 488.1. Knowledge of these may not be necessary if your controller's manual describes programming in terms of the twelve messages in the "HP-IB Message" column.

3-13. Remote Operation, Hewlett-Packard Interface Bus

The power meter can be operated through the Hewlett-Packard Interface Bus (HP-IB). HP-IB is Hewlett-Packard's implementation of ANSI/IEEE Standard 488.1 and the identical ANSI Standard MC1.1. Bus compatibility, programming, and data formats are described in the following paragraphs.

All front panel functions are programmable via HP-IB except setting the LINE switch and activating the **SHIFT** key. The **SHIFT** key is not programmable because the shifted functions have their own program codes. Additional functions are available in remote operation only.

A quick test of the power meter's HP-IB interface is described in this section under HP-IB Functional Checks. These checks verify that the power meter can respond to or send each of the applicable bus messages described in Table 3-2. For more information about HP-IB, refer to ANSI/IEEE Standard 488.1 (or the identical ANSI Standard MC1.1), the Hewlett-Packard Electronic Systems and Instruments catalog, and the booklet *Improving Measurements in Engineering and Manufacturing* (HP part number 5952-0058).

3-14 HP-IB Compatibility

The power meter's complete bus compatibility as defined by IEEE Standard 488 (and the identical ANSI Standard MC1.1) is described at the end of Table 3-2. Table 3-2 also summarizes the power meter's HP-IB capabilities in terms of the twelve messages in the "HP-IB Message" column.

3-15. Remote Mode

Remote Capability The power meter communicates on the bus in both remote and local modes. In remote, most of the power meter's front panel keys are disabled (exceptions are the LINE switch and the **LCL** key). Front panel displays, however, remain active and valid.

In remote, the power meter can be addressed to talk or listen. When addressed to listen, the power meter responds to the Data, Trigger, Clear (SDC), Remote, and Local messages. When addressed to talk, the power meter can issue the Data and Status Byte messages. Whether addressed or not, the power meter responds to the Clear (DCL), Local Lockout, Clear Lockout/Set Local, and Abort messages. In addition, the power meter may issue the Require Service and Status Bit messages.

Local-to-Remote Changes The power meter switches to remote operation upon receipt of the Remote message. The Remote message has two parts:

- a. the remote enable bus control line (REN) is set true, and,
- b. the device listen address is received once (while REN is true).

When the power meter switches to remote, the front panel RMT annunciator turns on. The power meter's control settings remain unchanged with the local-to-remote transition.

3-16. Local Mode

Local Capability In local, the power meter's front panel controls are fully operational and the instrument will respond to the Remote message. Whether it is addressed or not, it will also respond to the Clear, Local Lockout, Clear Lockout/Set Local, and Abort messages. When addressed to talk, the instrument can issue Data messages and the Status Byte message. Whether addressed or not, the instrument can issue the Require Service and Status Bit messages.

Remote-to-Local Changes The power meter always switches from remote to local whenever it receives the Local message (GTL) or the Clear Lockout/Set Local message. (The Clear Lockout/Set Local message sets the remote enable bus control line [REN] false.) If not in Local Lockout mode, the power meter switches to local from remote whenever the front panel **LCL** key is pressed.

Local Lockout A local lockout is recommended for purely automatic applications. Local lockout disables the **LCL** key and allows return-to-local only under program control.

Note



Return-to-local can also be accomplished by setting the power meter's LINE switch to OFF, then to ON. However, this technique has some disadvantages:

- a. Many of the power meter's parameters are set to default states. This may cause the measured power reading to change.
- b. There are several HP-IB conditions that reset to default states at turn-on.

3-17. Addressing

The power meter interprets the byte on the eight HP-IB data lines as an address or a bus command if the bus is in the command mode. The command mode is defined as the attention control line (ATN) being set true and the interface clear control line (IFC) set false. Whenever the power meter is addressed (whether in local or remote), either the talk (TLK) or listen (LSN) annunciator on the front panel turns on.

The power meter's HP-IB address is set in decimal from the front panel. HP-IB address switches (set in binary) are located inside the instrument. The only time the power meter reads the internal switches, however, is when the internal RAM contents storing the front panel address setting have been lost (for example, when the battery fails). Additional information for setting the internal switches is located in sections 2 and 8.

The power meter's HP-IB address can be set from the front panel as follows:

- a. Set power meter's LINE switch from OFF to ON while pressing and holding the **LCL** key.
- b. Release the **LCL** key.
- c. Enter the desired HP-IB address in decimal (0-30) and then press the **ENTER** key.

- d. To display the current HP-IB address setting in the front panel display, press and hold the **LCL** key.

Listen Only Mode The power meter is placed in Listen Only mode when its HP-IB address is set to 40. The Listen Only mode is provided to allow power meter to accept programming from devices other than controllers.

Talk Only Mode The power meter is placed in Talk Only mode when its HP-IB address is set to 50. In this mode, the instrument is configured to send data messages whenever the bus is in the data mode (attention control line [ATN] false).

3-18. Turn-on Default Conditions

Several HP-IB parameters are reset at turn-on. The parameters and their default conditions are listed below.

- HP-IB Local Mode
- Unaddressed
- Service Request Mask cleared
- Status Byte cleared
- Free Run Trigger Mode
- GT2 (Trigger with Delay) response to Trigger message
- Parallel Poll data line unassigned
- Display Enable active

3-19. Data Messages

The power meter communicates on the interface bus primarily with Data messages. Data messages consist of one or more bytes sent over the bus' data lines when the bus is in the data mode (ATN bus control line false). Unless it is set to Talk Only, the power meter receives Data messages when addressed to listen. Unless it is set to Listen Only, the power meter sends Data messages or the Status Byte message when addressed to talk.

Virtually all instrument operations available in local mode can be performed in remote mode via Data messages. The only exceptions are: changing the LINE switch, activating the **SHIFT** key, or changing the HP-IB address. The power meter may also be triggered via Data messages to make measurements at a particular time.

3-20. Receiving the Data Message

The power meter responds to Data messages when it is enabled to remote (REN bus control line true) and it is addressed to listen. The instrument remains addressed to listen until it receives its talk address, an Abort message, or a universal unlisten command.

Data Input Format The Data message string, or program string, consists of a series of ASCII codes. Each code is typically equivalent to a front panel keystroke in local mode. Thus, for a given operation, the program string syntax in remote mode is the same as the keystroke sequence in local mode. Example 1 shows a typical program string.

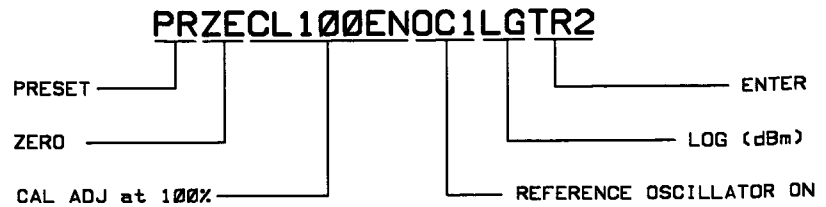
**EXAMPLE 1: Typical Program String**

Program Codes All of the HP-IB codes normally used by the operator to control the power meter are given in Table 3-6, HP-IB Code to Parameter Summary. All front panel keys except **LCL** and **SHIFT** have corresponding program codes. Lower case alpha characters are interchangeable with upper case characters. The number "0" and the letter "O" are not interchangeable.

Numeric data can be entered in fixed, floating point, or exponential format.

Note

All measurement parameter entries must be terminated with the program code "EN". (This is equivalent to pressing the **ENTER** key in local mode.) All frequency entries must be terminated with HZ, KZ, MZ, or GZ. For DUTY CYCLE (DY), CAL FAC (KB), and CAL (CL), the percent sign (%) can be used in place of EN.

Turning Off Functions When operating in local mode, OSC (reference oscillator) and REL (relative mode) toggle on and off with successive keystrokes. In remote mode these functions do not toggle on and off. Instead, a specific program code is required to turn off each function. Use RL0 to turn off REL mode and OC0 to turn off the reference oscillator.

Hold Range When the power meter is addressed to listen and receives program code RH (Range Hold), it switches from auto range to manual range using the current auto range value. If the power meter is already in manual range mode no action is taken. No range number is entered with this program code.

Hold Filter When the power meter is addressed to listen and receives program code FH (Filter Hold), it switches from auto filter mode to manual filter mode using the current auto filter value. If the power meter is already in manual filter mode no action is taken. No filter number is entered with this program code.

Limits The limits checking function allows the power meter to monitor the power present at each sensor and indicate when that power is outside preset limits. Enabling the limits checking function and setting limit values are available only via remote programming.

To set the the limits for a sensor, address the power meter to listen and then send a Data message consisting of program code LL (limit low) or LH (limit high), a numeric value, and program code EN (ENTER). The allowable range for limit values is -299.999 to $+299.999$. Values entered that are outside of this range cause the limit to be set to the minimum or maximum value as appropriate. Limit values are entered in dBm and converted automatically to Watts when necessary.

The limits checking function is enabled by program code LM1 and disabled by program code LM0. When the limits checking function is enabled, it uses the last values set for the high and low limits. PRESET (and the Clear message) sets both the high and low limits for Sensors A and B to 0.000 dBm and disables the limits checking function.

If the limits checking function is enabled and the input power exceeds the high limit or is less than the low limit, the condition is indicated on the front panel as well as over the bus. The out-of-limits condition is indicated on the front panel by the flashing A and/or B annunciator. The out-of-limits condition is indicated only for the sensor(s) used by the current measurement mode. The out-of-limits condition can be indicated over the bus by setting the Service Request Mask to enable an out-of-limits condition to issue the Require Service message. This condition can also be indicated by reading the Status Message.

Display Functions The selection of display functions is available only via remote programming. During local operation, the power meter display is enabled to indicate measurement results, error codes, entries in progress, and instrument status. In remote mode, two additional display functions are allowed: display disable and display all.

Display Enable (DE) This function is identical to local operation and is the function in effect when no other display function has been selected. This is the display function at turn-on. This condition is also established by PRESET and the Clear message.

Display Disable (DD) This function blanks out the front panel display. All readings over the bus remain valid. This function is cleared by sending another display function program code (DA or DE), by PRESET, or by the Power Meter receiving the Clear message.

Display All (DA) This function causes the power meter to turn on all front panel display LED segments. It is used to verify that all display segments are working properly. This function is cleared by sending another display function program code (DE or DD), by PRESET, or

by the power meter receiving the Clear message. (At turn-on, all the display segments light momentarily before the display enable becomes active.)

Triggering Measurements with the Data Message A feature that is only available via remote programming is the selection of free run, standby, or triggered operation of the power meter. During local operation the power meter is allowed to free run, outputting data to the display as each measurement is completed. In remote, three additional operating modes are allowed: hold, trigger immediate, and trigger with delay.

Hold (TR0) This mode is used to set up triggered measurements (initiated by program codes TR1, TR2, and the Trigger message). In trigger hold mode, internal settings can be altered by the instrument itself or by the user via the bus. The instrument, however, is inhibited from outputting any data to the front panel display or to the HP-IB except as follows. The instrument will issue the Status Byte message if serial polled.

The power meter leaves hold mode when it receives either the free run, trigger immediate, or trigger with delay program codes, or the Trigger message, or when it returns to local mode via the **LCL** key. Upon leaving hold, the front panel display is updated as the new measurement cycle begins. The Status Byte will be affected by the events that occur during the new measurement cycle.

Trigger Immediate (TR1) When the power meter receives the trigger immediate program code, it makes one measurement in the shortest possible time. The instrument then waits for the measurement results to be read. While waiting, the instrument can process most bus commands without losing the measurement results. However, if the instrument receives GET (Group Execute Trigger), a new measurement cycle will be executed. Once the measurement results are read onto the bus, the power meter reverts to the hold mode. Measurement results obtained via trigger immediate are normally valid only when the instrument is in a steady, settled state.

Trigger with Delay (TR2) Triggering with delay is identical to trigger immediate except the power meter inserts a settling-time delay before taking the requested measurement. This settling time is a function of the selected range and filter and is sufficient to produce valid, accurate measurement results.

Free Run (TR3) This mode is identical to local operation and is the mode of operation in effect when no other trigger mode has been selected. The measurement result data available to the bus is constantly being updated as rapidly as the power meter can make measurements. Entry into remote from local via the **LCL** key sets the power meter to the free run mode. (A local command from the controller does not return the power meter to free run mode.)

Program Order Considerations Although program string syntax is virtually identical to keystroke order, some program order considerations need highlighting.

Trigger Immediate and Trigger with Delay When either of the trigger program codes TR1 or TR2 is received by the power meter, a measurement is immediately initiated. Once the measurement is completed, some bus commands can be processed without aborting the measurement. However, any HP-IB program code sent to the power meter before the triggered measurement results have been completed will abort the trigger. Thus, trigger codes should always appear at the end of a program string, and the triggered measurement results must be completed before any additional program codes that affect measurement are sent.

ZERO and CAL ADJUST Zero the power meter before performing a calibration adjustment to avoid inaccurate measurement results.

OFFSET and Display Offset The display offset program code (DO) is only valid when it immediately follows the program code for OFFSET (OS). When the Power Meter is addressed to listen and receives the program string "OS DO EN" (a Data message), the offset that causes the power meter display to read 0 dB or dBm, 1.000 mW, or 100% (depending on the measurement units and measurement mode) is entered.

3-21. Sending the Data Message

The power meter sends Data messages when addressed to talk. The instrument remains configured to talk until it is unaddressed to talk by the controller. To unaddress the power meter, the controller must send the power meter's listen address, a new talk address, an Abort message or a universal untalk command.

Data Output Format As shown below, the output data is usually formatted as a real constant in exponential form: first the sign, then a digit, a decimal point, and four digits followed by the letter "E" and a signed power-of-ten multiplier. The string is terminated by a carriage return (CR) and line feed (LF). The power meter sends an EOI with the last byte of each output string.

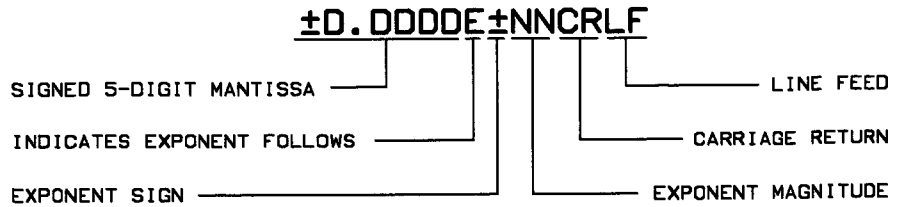

When an error is output to the bus, it follows the same format described above. As long as the front panel display indicates an error condition, the Power Meter sends 9.0000E+40 as the measured data when addressed to talk. To determine the error code, it is necessary to read the Status Message. Refer to the Status Message paragraph below for additional information.

Exceptions to this format are the data output for the following functions:

- Learn Mode #1
- Learn Mode #2
- Status Message
- Identification
- Service Request Mask Value

Each of these five functions is enabled by first addressing the power meter to listen. Then the power meter must receive a Data message with the appropriate program code. When the power meter is addressed to talk, it will output data for the selected function. The output format for these functions is described in the following paragraphs. Service Request Mask Value is explained later under Sending the Service Request Mask Value.

Learn Modes In addition to being able to store front panel setups in its own registers, the power meter has two learn modes that use the controller's memory. One learn mode allows the power meter to send instrument configurations to the controller's memory. The second learn mode is a subset of the first and transfers only information that can be stored in a STORE/RECALL register.

Whenever data is being transferred between controller and power meter, it must do so in uninterrupted strings. If a data string is broken or interrupted, the data could be lost or offset, and misinterpreted by the power meter. An offset of data bytes can persist until EOI is read.

Learn Mode #1 After receiving an LP1 program code (Learn Mode #1) and when addressed to talk, the power meter sends a string of up to 128 ASCII characters containing information on the instrument configuration. The last character is sent with EOI bus line true, thus terminating the message. This data can then be stored in the controller's memory for future use.

When the power meter is addressed to listen, the ASCII data string can be returned to the power meter. The power meter changes accordingly.

Table 3-3 shows the information contained in the string and the order in which it is sent.

Table 3-3. Learn Mode #1 Output Format

Parameter	Output from Power Meter ¹
Trigger Mode	TRx
Measurement Mode	AP, BP, AR, BR, AD, or BD
Sensor A Parameters	AE
Cal Factor	KB xxx.x EN
Offset	OS sxx.xx EN
Range	RA or RM x EN
Filter	FA or FM x EN
Low Limit	LL sxxx.xxx EN
High Limit	HL sxxx.xxx EN
Sensor B Parameters	BE
Cal Factor	KB xxx.x EN
Offset	OS sxx.xx EN
Range	RA or RM x EN
Filter	FA or FM x EN
Low Limit	LL sxxx.xxx EN
High Limit	HL sxxx.xxx EN
Active Entry Channel	AE or BE
Measurement Units	LG or LN
Reference Oscillator Status	OC0 or OC1
Group Trigger Mode	GTx
Limits Checking Status	LM0 or LM1
Carriage Return Line Feed	EOI

¹ "s" indicates sign; "x" indicates a single digit

Learn Mode #2 After receiving the program code LP2 (Learn Mode #2) and when addressed to talk, the power meter sends 2 ASCII characters, @ and 2, followed by a string of 28 8-bit binary bytes. The last byte is sent with EOI bus line true, thus terminating the message. This binary data can then be stored in the controller's memory.

The most straight-forward way to program the system controller is to use a loop to read 30 binary characters and store them in an array. Learn Mode #2 requires a controller that can transfer information in binary form.

This string contains the following information:

- Measurement mode
- REL mode status (on or off)
- Reference oscillator status (on or off)
- Current reference value if in REL mode
- Measurement units (Log or Lin)
- Cal Factor for each sensor
- Offset for each sensor
- Range for each sensor
- Filter for each sensor

When the power meter is addressed to listen, the binary data can be returned to the power meter. The power meter changes accordingly.

Status Message This function enables the power meter's current state to be read under program control. After receiving an SM program code (Status Message) and when addressed to talk, the power meter sends a string of 23 ASCII characters followed by carriage return (CR), line feed (LF), and EOI. The Status Message is updated only after a measurement. The Status Message can be interpreted with the information shown in Figure 3-6.

Note

In order to obtain Measurement Units (E) in % and dB, enter the following program:

```

10 DIM Units$[7]
20 DIM Sm$[25]
30 PM=713
40 ENTER Pm;Dummy      !Update Status Message
50 OUTPUT Pm;"SM"
60 ENTER PM;Sm$        !Read Status Message
70 !
80 ! Check for Rel Mode or two channel operation
90 !
100 IF Sm$[18,18]="1" OR (VAL(Sm$[6,6])>1 AND VAL(Sm$[6,6])<6) THEN
110  SELECT Sm$[15,15]  ! Check for Log or Linear Mode
120    CASE "0"
130      Units$=" %"
140    CASE "1"
150      Units$=" dB"
160    CASE ELSE
170      Units$=" "
180  END SELECT
190  IF Sm$[18,18]="1" THEN Units$=Units$&" Rel"
200 ELSE                ! Not Rel mode or two channel operation
210  SELECT Sm$[15,15]  ! Check for Log or Linear Mode
220    CASE "0"
230      Units$="WATTS"
240    CASE "1"
250      Units$=" dBm"
260  END SELECT
270 END IF
280 END

```

Identification This function is used to identify the the power meter's model number and the firmware version. After receiving program code ?ID and when addressed to talk, the power meter sends the following string: HP438A,VERX.XX. Where HP438A is the instrument model number and VERX.XX is the firmware version number.

3-22. Receiving the Clear Message

The power meter responds to the Clear message by assuming the same conditions as established by PRESET. Refer to Table 3-4. The power meter responds equally to the Selected Device Clear (SDC) bus command when addressed to listen, and the Device Clear (DCL) bus command whether addressed or not.

3-23. Receiving the Trigger Message

When in remote and addressed to listen, the power meter responds to a Trigger message (the Group Execute Trigger bus command [GET]) by executing one of the pre-programmed codes shown in Table 3-5. If none of the codes has been preprogrammed (via a Data message), the power meter responds to the Trigger message by executing one settled-measurement cycle (GT2), which is the default condition at turn-on. Refer to Triggering Measurements with the Data Message, discussed earlier in this section.

Note



Hardware Errors NOT available via the Status Message

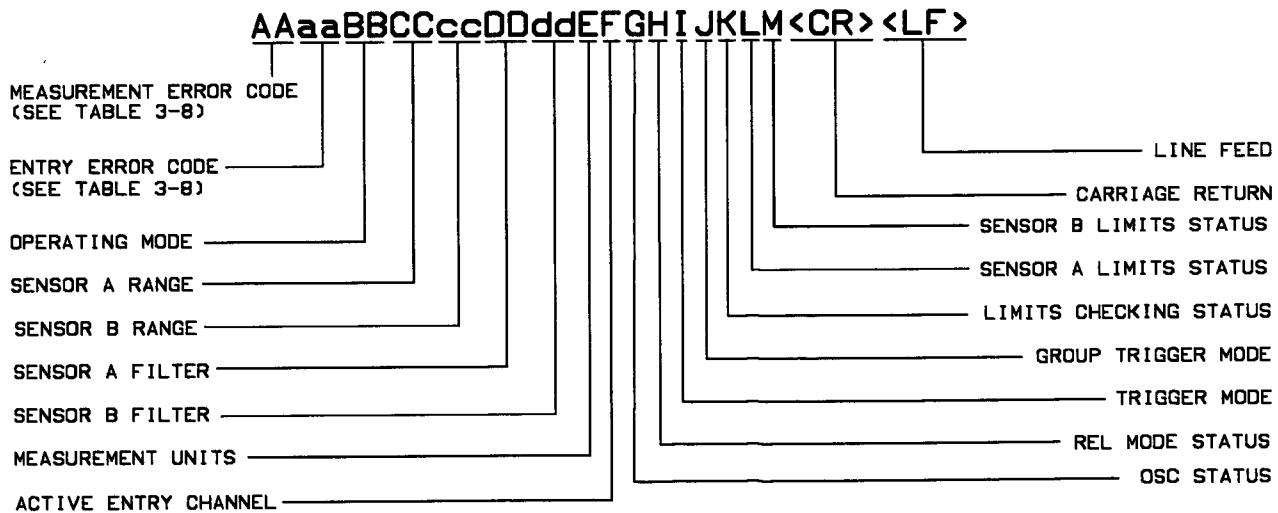

Figure 3-6. Status Message Output Format

Codes Used in Status Message

BB	CC cc	DD dd	E	F	G	H	I	J	K	LM
Operating Mode	Range	Filter	Measurement Units	Active Entry Channel	Osc Status	REL Mode Status	Trigger Mode	Group Trigger Mode	Limits Checking Status	Sensor A & B Limits Status
00=Sensor A	Manual	Manual								
01=Sensor B	Range	Filter	0=Watts	A=A	0=Off	0=Off	0=Free	0=GTO	0=Disabled	0=In limits
02=A/B	01=1	00=1	00=0	1=dBm	B=B	1=On	Run			1=Over high limit
03=B/A	02=2	01=1					1=Hold	1=GT1	1=Enabled	
04=A-B	03=3	02=2								
05=B-A	04=4	03=3						2=GT2		2=Under low limit
06=Zeroing A	05=5	04=4								3=Over high limit
		05=5								
		06=6								
07=Zeroing B	Auto Range	07=7								and under low limit
		08=8								
08=Cal A	11=1	09=9								
09=Cal B	12=2	Auto								
10=Ext Cal A	13=3	Filter								
11=Ext Cal B	14=4	10=0								
	15=5	11=1								
		12=2								
		13=3								
		14=4								
		15=5								
		16=6								
		17=7								
		18=8								
		19=9								

Table 3-4. Response to a Clear Message (and PRESET)

Parameter	Condition
Sensor A	
CAL ADJ	100.0%
CAL FACTOR	100.0%
OFFSET	0.00 dB
Filter	AUTO
Range	AUTO
Low Limit	0.000 dBm
High Limit	0.000 dBm
Sensor B	
CAL ADJ	100.0%
CAL FACTOR	100.0%
OFFSET	0.00 dB
Filter	AUTO
Range	AUTO
Low Limit	0.000 dBm
High Limit	0.000 dBm
Display	Sensor A
OSC	Off
Entry Channel	SET A
Measurement Units	WATT
Limits Checking	Off
REL	Off
Trigger Mode	Free Run
Group Execute Trigger Mode	GT2
Display Function	Display Enable

Table 3-5. Response to a Trigger Message

Program/Code	Power Meter Response
GT0	Ignore Group Execute Trigger
GT1	Trigger Immediate (TR1)
GT2	Trigger with Delay (TR2)

3-24. Receiving the Remote Message

The Remote message has two parts. First, the remote enable bus control line (REM) is held true, then the device listen address is sent by the controller. These two actions combine to place the power meter in remote mode. Thus, the power meter is enabled to go into remote when the controller begins the Remote message, but it does not actually switch to remote until addressed to listen the first time. No instrument settings are changed by the transition from local to remote. When actually in remote, the power meter lights the front panel RMT annunciator.

3-25. Receiving the Local Message

The Local message is the means by which the controller sends the Go To Local (GTL) bus command. If addressed to listen, the power meter returns to front panel control when it receives the Local message. If the instrument was in local lockout when the Local message was received, front panel control is returned, but lockout is not cleared. Unless it receives the Clear Lockout/Set Local message, the power meter will return to local lockout the next time it goes to remote. No instrument settings are changed by the transition from remote to local.

When the power meter goes to local mode, the front panel RMT annunciator turns off. However, when the power meter is being addressed (whether in local or remote), its front panel LSN or TLK annunciator lights.

3-26. Receiving the Local Lockout Message

The Local Lockout message is the means by which the controller sends the Local Lockout (LLO) bus command. If in remote, the power meter responds to the Local Lockout message by disabling the front panel LCL key. The local lockout mode prevents loss of system control due to someone accidentally pressing front panel keys. If, while in local, the power meter is enabled to remote (that is, REN set true) and it receives the Local Lockout message, it will switch to remote mode with local lock-out the first time it is addressed to listen. When in local lockout, the power meter can be returned to local only by the controller (using Local or Clear Lockout/Set Local messages) or by setting the LINE switch to OFF and back to ON or by removing the bus cable.

3-27. Receiving the Clear Lockout/Set Local Message

The Clear Lockout/Set Local message is the means by which the controller sets the Remote Enable (REN) bus control line false. The power meter returns to local mode (full front panel control) when it receives the Clear Lockout/Set Local message. When the power meter goes to local mode, the front panel RMT annunciator turns off.

3-28. Receiving the Pass Control Message

The power meter does not respond to the Pass Control message because it cannot act as a controller.

3-29. Sending the Require Service Message

The power meter sends the Require Service message by setting the Service Request (SRQ) bus control line true. The instrument can send the Require Service message in either local or remote mode. When the power meter is sending the Require Service message, the front panel SRQ annunciator lights. The Require Service message is cleared when a serial poll is executed by the controller or when a “CS” (clear status) program code is received via a Data message.

There are five conditions that can be enabled to cause the Require Service message to be sent. These conditions, which are enabled by the Service Request Mask, are described below.

Data Ready: When the power meter has a data point requested by a trigger command.

Cal/Zero Completed: When the power meter has completed a calibration or zeroing cycle.

Entry Error: When a number is entered that is out of the allowable range for the selected parameter.

Measurement Error: When the power applied to the sensors is incorrect for the current instrument configuration.

Over/Under Limits: When the limits checking function is enabled and the measured power is greater than the high limit or lower than the low limit.

Service Request Mask The Service Request Mask determines which bits can set the Status Byte’s RQS bit true (see Table 3-6). When the RQS bit is true, the SRQ bus line is also true.

The Service Request Mask is set by the program code “@1” followed by an 8-bit byte (a Data message). The value of the byte is determined by summing the weight of each bit to be checked. Each bit, if true, enables the corresponding condition to set the RQS bit true. At turn-on, the Service Request Mask is cleared (that is, set to 0).

· Sending the Service Request Mask Value (a Data Message). After receiving an RV program code (Service Request Mask value) and when addressed to talk, the Power Meter will send a single binary word (8 bits) that describes the present state of the mask. The bit pattern can be interpreted with the information in Table 3-6.

Note



This byte is sent with the bus EOI line true, thus terminating the message.

3-30. Sending the Status Byte Message

After receiving a Serial Poll Enable (SPE) bus command and when addressed to talk, the power meter sends the Status Byte message. The Status Byte message consists of one 8-bit byte in which five of the bits are set according to the conditions described under Sending the Require Service Message. The bit pattern of the Status Byte is shown in Table 3-6. Note that bits 6 and 8 are always set to 0. The remaining bit is the RQS bit.

If one or more of the five conditions described above is both present and enabled by the Service Request Mask, the bits corresponding to the conditions and also bit 7, the RQS bit, are set true (and the Require Service message is sent). If one or more of the five conditions occurs but has not been enabled by the Service Request Mask, the corresponding bits are still set true. However, if a condition has not been enabled by the mask, it cannot cause the RQS bit to be set true.

Once the power meter receives the serial poll enable (SPE) bus command, it is no longer able to alter the status byte. If a bit has been enabled and that condition occurs after the RQS bit has been set true, the bit is stored in a buffer and is read the next time the power meter receives the SPE bus command.

Table 3-6. The Status Byte and Service Request Mask

Bit	7	6	5	4	3	2	1	0
Weight	128	64	32	16	8	4	2	1
Condition	0	RQS Bit Require Service	0	Over/Under Limit	Measurement Error	Entry Error	Cal/Zero Complete	Data Ready

After the Status Byte message has been sent, it will be cleared if the Serial Poll Disable (SPD) bus command is received, if the Abort message is received, or if the power meter is unaddressed to talk. Bits stored in the buffer waiting to be read, however, are not cleared. Regardless of whether or not the Status Byte message has been sent, the Status Byte and any Require Service message pending will be cleared if a Clear Status (CS) program code is received by the Power Meter.

3-31. Sending the Status Bit Message

The power meter sends the Status Bit message (if configured to do so) as part of the interface's response to the Parallel Poll Enable (PPE) bus command. In order for the power meter to respond to a PPE bus command, the instrument must be assigned a single HP-IB data line on which to respond by the controller. The controller also assigns the logic sense of the bit. Both tasks are accomplished by the Parallel Poll Configure (PPC) bus command. If the power meter is sending the Require Service message, it will set its assigned status bit true. The power meter can send the Status Bit message without being addressed to talk.

The data line on which the power meter is assigned to respond is cleared by sending the Parallel Poll Unconfigure (PPU) bus command. At turn-on, the data line is unassigned.

3-32. Receiving the Abort Message

The Abort message is the means by which the controller sets the Interface Clear (IFC) bus control line true. When the Abort message is received, the Power Meter becomes unaddressed and stops talking and listening.

3-33. HP-IB Syntax and Characteristics Summary

Address Set in decimal from the front panel. Set the LINE switch to ON while pressing the **LCL** key. Release the **LCL** key, enter the desired address, and press the **ENTER** key. Factory set to 13.

Data input Format Typically the same as front panel keystrokes in local mode. All numeric entries sent over the HP-IB must be terminated with program code "EN" (for ENTER).

Data Output Format Output format when no other talk mode has been defined:

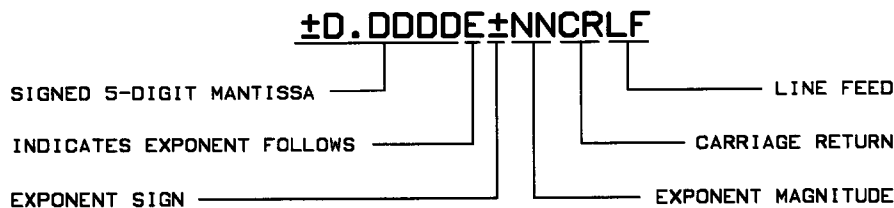

Output format for Learn Mode #1 (program code LP1) Up to 128 ASCII characters [EOI]

Output format for Learn Mode #2 (program code LP2) 30 bytes [EOI]

Output format for identification (program code 71 D) HP438AVERx.xx [EOI]

Output format for Status Message (program code SM) 23 ASCII characters [EOI]

Output format for Service Request Mask Value (program code RV) 1 byte [EOI]

Return to Local Front panel **LCL** key if not locked out.

Status Byte

Bit	7	6	5	4	3	2	1	0
Weight	128	64	32	16	8	4	2	1
Service Request Condition	0	RQS Bit Require Service	0	Over/Under Limit	Measurement Error	Entry Error	Cal/Zero Complete	Data Ready

Notes:

The condition indicated in bits 1-5 must be enabled by the Service Request Mask to cause a Service Request Condition. The mask is set with the @1 program code followed by an 8-bit byte. The value of the byte is determined by summing the weight of each bit to be checked.

The RQS bit (bit 7) is true when any of the conditions of bits 1-5 are enabled and occur.
Bits remain set until the Status Byte is cleared.

Complete HP-IB capability (as described in IEEE Std 488-1978 and ANSI Std MC1.1):
SH1, AH1, T5, TE0, L4, LE0, SR1, RL1, PP1, DC1, C0.

Table 3-7. HP-IB Codes to Parameter Summary

HP-IB Code	Parameter	HP-IB Code	Parameter
AD	Sensor A minus Sensor B measurement	LL ^{1,2}	Low Limit
AE	SET A	LM0 ¹	Disable limits checking function
AP	Sensor A measurement	LM1 ¹	Enable limits checking function
AR	A/B ratio measurement	LN ¹	Linear (Watts or %)
BD	Sensor B minus Sensor A measurement	LP1	Learn Mode #1
BE	SET B	LP2	Learn Mode #2
BP	Channel B measurement	OC0 ¹	Reference Oscillator off
BR	B/A ratio measurement	OC1 ¹	Reference Oscillator on
CL ^{1,2}	CAL ADJ	OS ^{1,2}	OFFSET
CS ¹	Clear Status Byte	PR ¹	PRESET
DA ¹	Display All	RA ¹	AUTO RANGE
DD ¹	Display Disable	RC ^{1,2}	RECALL
DE ¹	Display Enable	RH ¹	Range Hold
DO	DSP → OFS	RL0 ¹	Exit REL mode
EN ¹	ENTER	RL1 ¹	Enter REL mode
FA	AUTO FILTER	RM ^{1,2}	MNL RANGE
FH	Filter Hold	RV ¹	Service Request Mask Value
FM ^{1,2}	MNL FILTER	SM ¹	Status Message
GTO ¹	Ignore Group Execute Trigger (GET) bus command	ST ^{1,2}	STORE
GT1 ¹	Trigger Immediate response to Group Execute Trigger	TR0 ¹	Trigger Hold
GT2 ¹	Trigger with Delay response to Group Execute Trigger	TR1 ¹	Trigger Immediate
KB ^{1,2}	CAL FACTOR	TR2 ¹	Trigger with Delay
LG ¹	Log (dB or dBm)	TR3 ¹	Trigger - Free Run
LH ^{1,2}	High Limit	ZE ¹	ZERO
		@1 ¹	Prefix for Service Request Mask
		?ID ¹	Identification

1 These commands are fully compatible with the HP 437B Power Meter HP-IB command codes.

2 Requires numeric entry followed by program code EN.

Cal Adj

Description

CAL ADJ is used to calibrate the power meter and any compatible power sensor to a known reference. During the calibration cycle, the gain of the power meter is adjusted so that the front panel display reads $1.000-3$ (1 mW) when the sensor is connected to a 1.00 mW reference oscillator.

Pressing the **CAL ADJ** key enables entry of the reference calibration factor for the active entry channel. The reference calibration factor is the sensor's calibration factor at 50 MHz. The allowable range of values for CAL ADJ is 50.0 to 120.0%.

The power meter calibrates to an external reference source if the entered reference calibration factor is negative. If the entered reference calibration factor is positive, the power meter calibrates to the 1.00 mW internal reference oscillator.

Procedure

Connect the sensor to either channel A or channel B via a power sensor cable, and set the active entry channel accordingly. Press **ZERO**. (Be sure that no RF power is applied to the sensor during the zero routine.) When the power meter has finished zeroing, connect the sensor to the 1.00 mW reference oscillator. Press **CAL ADJ**. Enter the reference calibration factor in percent. Press **ENTER**.

Both channels must be calibrated with their own sensors for dual sensor measurements.

Example

To calibrate a sensor to the power meter with a reference cal factor of 98.5%:

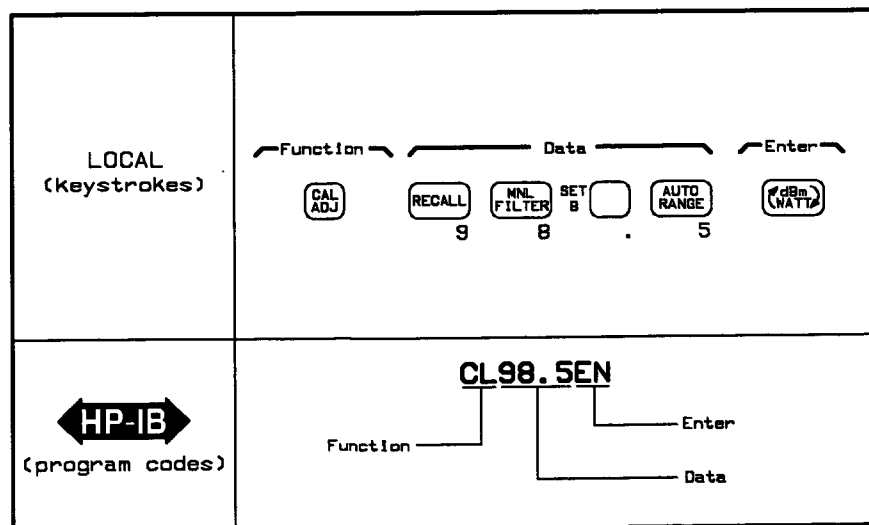

Program Codes

Parameter	Program Code
CAL ADJ	CL
ENTER	EN

Indications

After the **CAL ADJ** key has been pressed, the power meter will display "ENT _ _ _ _". Once the reference cal factor has been entered, the instrument goes through its calibration routine, and the display shows eight dashes and a moving decimal point.

Comments

The reference calibration factor, which is entered via CAL ADJ, is used only during calibration. Calibration factors entered via CAL FACTOR are used for actual measurements.

Zero the active entry channel before entering the reference calibration factor.

The reference calibration factor can be found on the body of the sensor.

A calibration should be performed whenever the power meter changes power sensors or whenever the ambient temperature changes by more than 5°C.

PRESET sets CAL ADJ to 100%. The gain of the power meter, however, does not change until a new calibration is performed.

Pressing **CAL ADJ** and then **ENTER** without entering any data causes the power meter to initiate a calibration using the last entered value for CAL ADJ.

Any command received during the calibration process aborts the calibration and executes the function of the command received. The number entered for CAL ADJ, however, is stored as the last entered value.

When using an older HP 8483A Power Sensor, enter a reference calibration factor of 96%, even though 100% may be indicated on the sensor's cal factor label. Using this CAL ADJ value compensates for mismatch between the 75-ohm sensor and the 50-ohm reference oscillator. Newer HP 8483A Power Sensors have the correct reference cal factor (96%) or less printed on the label and should be used.

If an HP 8484A Power Sensor with its associated HP 11708A Reference Attenuator is used, the front panel display reads 1.0000-ε instead of 1.0000-3.

Offset settings are ignored during calibration.

Error 57 occurs when the instrument is turned on and the internal RAM contents have been lost. This is generally due to battery failure, but may also occur when the power meter is powered down during calibration or zeroing. The error is cleared after two seconds or by selecting any other function. Once the error is cleared, the power meter is configured to the PRESET state and the HP-IB address is read from the internal address switch.

Because of the variety of sensor power ranges, the power meter always auto ranges during calibration. After calibration the previous range setting is restored.

If the CAL ADJ entry is positive, the power meter first checks that the sensor is connected to the reference oscillator by turning the oscillator on and off and watching for a power level change on the sensor. If the sensor is connected, the reference oscillator is turned on for the calibration and returned to its former state upon completion of the calibration.

Related Section

CAL FACTOR
Error Messages
SET A and SET B
PRESET
ZERO

Cal Factor

Description

The calibration factor compensates for mismatch losses and effective efficiency over the frequency range of the power sensor.

Pressing the **CAL FACTOR** key enables entry of the calibration factor for the sensor connected to the active entry channel. (A chart of CAL FACTOR % versus Frequency is printed on each sensor and an accompanying data sheet.) Calibration factor is entered in percent. Valid entries for CAL FACTOR range from 1.0 to 150.0%. Front panel numeric entry allows up to 4 digits. After the first four digits are entered, succeeding digits are ignored. Only one digit to the right of the decimal point is accepted. Data entered over the bus (in remote mode) is rounded to the required resolution.

Procedure

Cal factor is entered separately for sensor A or sensor B. To enter the cal factor for the active entry channel, press **CAL FACTOR**, enter the cal factor in percent, and then press **ENTER**.

Example

To enter a cal factor of 99%:

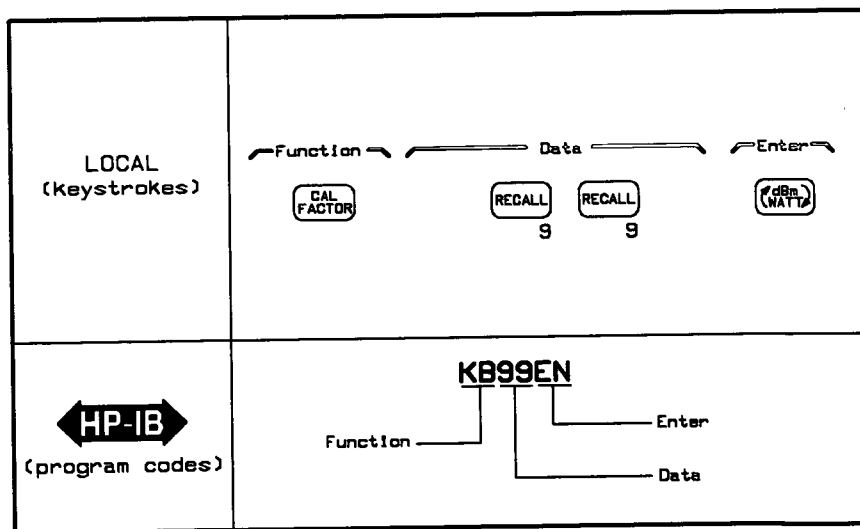

Program Codes

Parameter	Program Code
CAL FACTOR	KB
ENTER	EN

Indications

When the **CAL FACTOR** key is pressed, the front panel display shows "ENT_ _ _". After a number has been entered and the **ENTER** key has been pressed, the display returns to its previous mode.

The front panel displays the value of the calibration factor(s) used in the current measurement.

Comments

During actual measurements, calibration factors entered via **CAL FACTOR** are used. The reference calibration factor, which is entered via **CAL ADJ**, is used only during the calibration cycle.

Pressing **CAL FACTOR** and then **ENTER** without entering any data sets the calibration factor to 100%.

PRESET sets the calibration factor of both sensor A and sensor B to 100%.

Related Sections

CAL ADJ
PRESET
SET A and SET B
STORE and RECALL

dBm/WATT (Logarithmic/Linear Units)

Description

The **dBm/WATT** key can be used to express measurement results in logarithmic or linear units. The following table shows which units are applicable to the individual measurement modes.

Measurement Mode	REL Off ¹		REL on ¹	
	Lin	Log	Lin	Log
Single Sensor	Watt	dBm	%	dB
Ratio	%	dB	%	dB
Difference	Watt	dBm	%	dB

¹ When REL (relative mode) is on, the measurement is compared to a reference value. The reference value is the first value read when REL is activated.

The **dBm/WATT** key allows any measurement result to be viewed in logarithmic or linear format.

Procedure

Pressing the **dBm/WATT** key alternates the display between the logarithmic and the linear functions. When the measurement mode is changed, the logarithmic or linear setting of the **dBm/WATT** key remains the same.

Example

If the power meter display reads 1.000 mW, to display this value in dBm:

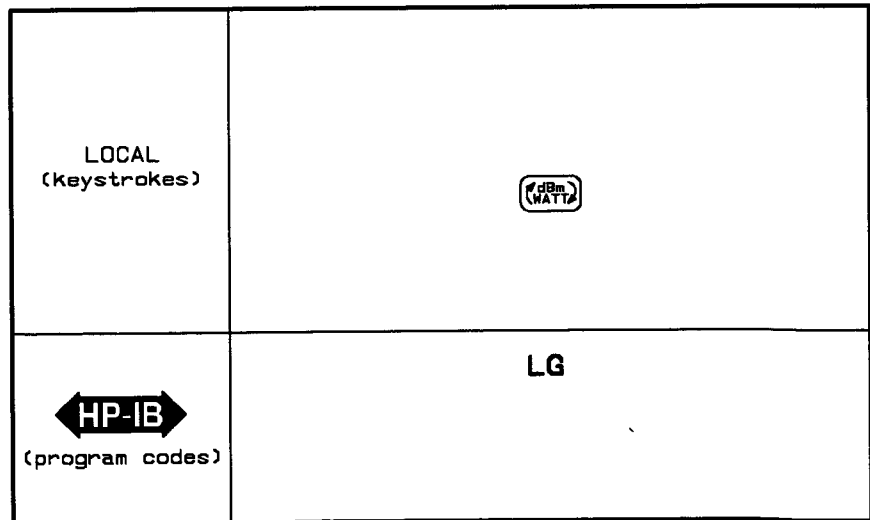

Program Codes

Parameter	Program Code
Logarithmic Units (dBm or dB)	LG
Linear Units (Watts or %)	LN

Indications

The status of the **dBm/WATT** key can be determined by observing the current measurement mode, the measurement unit annunciators, and the table above.

Comments

Logarithmic units cannot be used with a measured value that is zero or negative. If the value is zero or negative, Error 27 (illegal logarithmic operation) will be displayed.

With REL mode off, logarithmic units cannot be used to display A-B difference measurements where the SENSOR A power level is less than the SENSOR B power level. Likewise (with REL mode off), logarithmic units cannot be used to display B-A difference measurements where the SENSOR B power level is less than the SENSOR A power level.

PRESET sets the measurement units to Watts (linear units).

With no power applied to the sensor, the displayed power in single sensor measurement mode drifts both negative and positive (about zero). If the power meter is in logarithmic mode, negative drift results in a log error (Error 27). This is normal and does not require corrective action.

Related Sections

Error Messages
 PRESET
 REL (Relative Measurements)
 SENSOR A-B and SENSOR B-A

Error Messages

Description

The power meter generates error messages to indicate operating problems, incorrect keyboard or HP-IB entries, and service related problems.

Error messages are grouped as follows:

Errors 01 through 49 These are measurement errors, which indicate that not all conditions have been met to assure a calibrated measurement. Measurement errors can usually be cleared by readjusting the front panel controls or changing the equipment setup.

Errors 60 through 59 and 90 through 99 These are entry errors, which indicate that an invalid keyboard or HP-IB entry has been made. These errors require that a new entry or function selection be made.

Errors 60 through 69 These are service errors, which provide service-related information. Service errors are discussed in section 8 of the manual.

Error Displays

Errors are indicated on the front panel. The left side of the display shows a brief message (eight characters or less) indicating the nature of the problem. The right side of the display indicates the error code. In addition, the channel on which the error occurs is indicated in the right side of the display for some errors.

HP-IB Output Format

As long as the front panel display indicates an error condition, the instrument sends 9.0000E+40 as the measured data when addressed to talk.

If an error condition generates SRQ, the status byte and status message latch the error until the status message (program code SM) has been read by the HP-IB controller. Once the status message has been read, the status byte and status message are cleared if the error condition no longer exists. If multiple errors occur, the status message indicates the most recent error.

If an error condition does not generate SRQ (for example, the Service Request Mask has been set such that measurement or entry errors do not set the status byte's RQS bit true), the status byte and status message latch all entry errors. Measurement errors, however, are latched only if 9.0000E+40 has been sent over the HP-IB. The status byte and status message are cleared by removing the cause of the error and then reading the status message over the HP-IB.

Error Messages

Table 3-8, Error Messages, describes all measurement and entry errors. The error code, front panel error display, message, and action typically required to remove the error causing condition are given.

Table 3-8. Error Messages

Error Code	Error Display	Message	Action Required
Measurement Errors			
01	Cannot 0	Power meter cannot zero sensor A	Ensure that no RF power is being applied to sensor A.
02	Cannot 0	Power meter cannot zero sensor B	Ensure that no RF power is being applied to sensor B.
03	no rEF	Sensor A is not connected to reference oscillator during calibration	Connect sensor A to reference oscillator. Enter a negative reference cal factor if an external reference source is used. If error persists, check output of reference oscillator.
04	no rEF	Sensor B is not connected to reference oscillator during calibration	Connect sensor B to reference oscillator. Enter a negative reference cal factor if an external reference source is used. If error persists, check output of reference oscillator.
05	Cal-Err	Power meter cannot calibrate sensor A	Check sensor A connection to reference oscillator. Reference must be 1 mW.
06	Cal-Err	Power meter cannot calibrate sensor B	Check sensor B connection to reference oscillator. Reference must be 1 mW.
11	inPut-OL	Input overload on sensor A	Reduce input power to sensor A. ¹
12	inPut-OL	Input overload on sensor B	Reduce input power to sensor B. ¹
15	PLEASE 0	Sensor A's zero reference has drifted negative	Zero sensor A. If error persists, check input power.
16	PLEASE 0	Sensor B's zero reference has drifted negative	Zero sensor B. If error persists, check input power.
17	up rNg	Input power on sensor A is too high for current range	Select a higher range or reduce input power to sensor A. ²
18	up rNg	Input power on sensor B is too high for current range	Select a higher range or reduce input power to sensor B. ²
25	CALC OF	Overflow error	Change either the input power, offset, cal factor or measurement mode. ³

1 This error occurs when the input power exceeds 120% of the full-scale power for range 5 and only when the power meter is on range 5.

2 This error occurs when the power meter is on manual range and the input power exceeds 120% of full-scale for ranges 1,2,3, and 4.

3 Power calculations result in a value that is too large to calculate or display. The combination of input power, offset, cal factor and measurement mode results in a value whose absolute value is greater than 3.4028E+38.

Table 3-8. Error Messages (continued)

Error Code	Error Display	Message	Action Required
Measurement Errors (continued)			
26	CALC UF	Underflow error	Change either the input power, offset, cal factor or measurement mode. ¹
27	LOf Err	Illegal logarithmic operation	Change to linear measurement units, zero the power meter with no RF input power, or increase input power to greater than 0 Watts.
28	rEL Err	Invalid or missing reference value	Exit REL mode. ²
31	no Ch a	Channel A does not have a sensor connected to it	Connect a sensor to channel A or change channels (assuming a sensor is connected to channel B).
32	no Ch b	Channel B does not have a sensor connected to it	Connect a sensor to channel B or change channels (assuming a sensor is connected to channel A).
33	2 inPut \bar{s}	Both front and rear sensor A inputs have sensors connected (Option 002 only)	Remove one of the 2 sensors connected to sensor A input.
34	2 inPut \bar{s}	Both front and rear sensor B inputs have sensors connected (Option 002 only)	Remove one of the 2 sensors connected to sensor B input.

¹ Power calculations result in a value that is too small to calculate or display. The combination of input power, offset, cal factor and measurement mode results in a value whose absolute value is greater than 1.1755E-38.

² This error is cleared after two seconds or by selection of any other function.

Table 3-8. Error Messages (continued)

Error Code	Error Display	Message	Action Required
Entry Errors			
50	CF Error	Entered cal factor is out of range	Re-enter value between 1.0 and 150.0 ¹
51	OS Error	Entered offset is out of range	Re-enter value between -99.99 and +99.99 ¹
52	rg Error	Entered range number is out of range	Re-enter range number between 1 and 5 ¹
53	FL Error	Entered filter number is out of range	Re-enter filter number between 0 and 9. ¹
54	rc Error	Entered recall register number is out of range	Re-enter register number between 0 and 19. ¹
55	st Error	Entered storage register number is out of range	Re-enter register number between 1 and 19 ¹
56	rCF Err	Entered reference cal factor is out of range	Re-enter CAL ADJ value between 50.0 and 120.0 ¹
57	rCL Fail	Continuous memory failure	Refer to footnote below ²
58	Ad Error	Entered HP-IB address is out of range	Re-enter HP-IB address between range 0-30, 40-49, or 50-59. ¹
90		HP-IB data without valid prefix	Check, then re-enter valid prefix with data.
91		Invalid HP-IB code	Check, then re-enter correct HP-IB code.
Hardware Errors			
61-69		Service-related errors	Refer to Service-Related Errors in section 8, "Service"

1 This error indication is cleared after two seconds or by selecting any function. (The selected function will be executed.) When the error is cleared, the parameter that caused the error remains unchanged from its previous value.

2 Error 57 occurs when the instrument is turned on and the internal RAM contents have been lost. This is generally due to battery failure, but may also occur when the power meter is powered down during the end of a zero or calibration sequence. The error indication is cleared after two seconds or by selecting another function. (The selected function will be executed). Once the error indication is cleared, the power meter is configured in the PRESET state and the HP-IB address is taken from the value defined on the internal address switch.

Note



Hardware Errors NOT reported via SRQ.

Filters

(Includes AUTO FILTER and MNL Filter)

Description

The purpose of filtering is to reduce jitter in the display. Measured values are averaged with previous values before being displayed.

The power meter uses a variable digital filter to average power readings. The value shown in the display is the average of the last 2^N readings, where 2^N is the filter length and N is the filter number. The filter length can range from 1 (2^0) to 512 (2^9).

When a new power measurement is input to the filter, it is saved and the oldest reading is discarded. If the power meter's configuration changes such that the values in the filter are no longer valid (for example, a change in measurement mode, range or filter setting), the filter contents are set to zero. The filter starts filling up again, and the power meter displays the average of the accumulated power readings.

The filter length can be selected automatically (via AUTO FILTER) or manually (via MNL FILTER). For most applications, auto filter is the best mode of operation. Manual filter mode is useful mainly in specialized applications requiring high resolution or fast settling times.

In auto filter mode, the power meter automatically sets the filter length to satisfy the filtering requirements for most power measurements. The filter length depends solely upon the power range in which the power meter is currently operating. The following table lists the filter length and filter number for each range when the power meter is in auto filter mode.

Auto Filter Setting for Each Range		
Range	Filter Length	Filter Number
1	128	7
2	8	3
3	2	1
4	1	0
5	1	0

When the filtering is selected automatically, the resolution is four significant digits for measurements displayed in Watts or percent. The resolution is 0.01 dB for measurements displayed in dB or dBm.

In manual filter mode, the filter length is selected by entering a filter number between 0 and 9. Refer to the following table to cross-reference filter numbers to filter lengths.

Filter Number	Filter Length
0	1
1	2
2	4
3	8
4	16
5	32
6	64
7	128
8	256
9	512

Note



The filter length is independent of the measurement power range when the filter length is set manually.

An additional feature of the power meter is the hold filter mode. Hold filter mode provides a means of switching from auto filter mode to manual filter mode while retaining the auto filter setting.

Procedure

The filter length is set for the active entry channel. For dual sensor measurements, the filter length should be set for each sensor. To automatically select the filter length, press **AUTO FILTER**. To manually select the filter length, press **MNL FILTER**, enter a number (0-9), and then press **ENTER**. (The filter length is the result of 2 being raised to the power of the filter number.) To select hold filter mode, press **MNL FILTER** and then **ENTER**.

Example

To manually set the filter length to 128 (filter number=7):

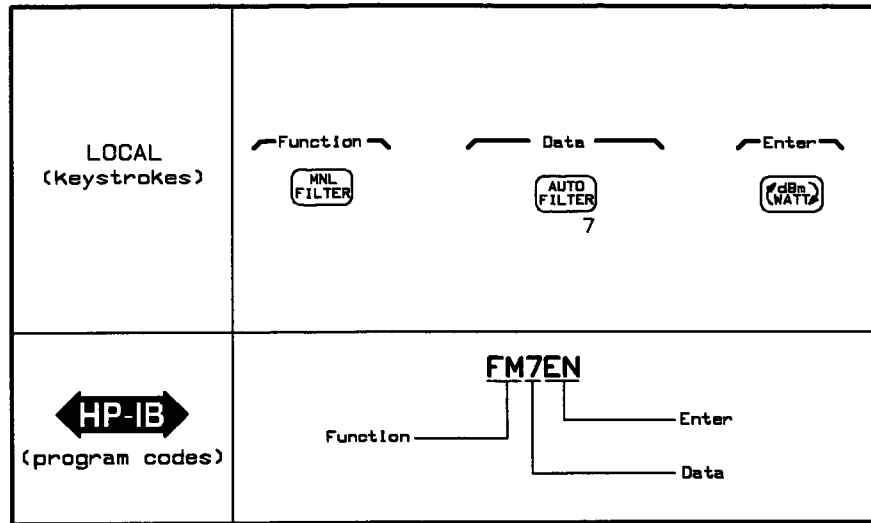

Program Codes

Parameter	Program Code
AUTO FILTER	FA
MNL FILTER	FM
Hold filter	FH
ENTER	EN

Indications

The MNL annunciator on the front panel display lights when the power meter is in manual filter or manual range mode. There is no front panel indication when the power meter is in auto filter mode.

Comments

By manually selecting a filter length that is significantly longer than the auto filter mode default length, the resolution of the display can be extended to five digits in Watts or to 0.001 in dBm on some power ranges. The range setting and filter number required for high resolution is defined in the following table.

Range	Filter Number Required for High Resolution
1	High resolution not available
2	8, 9
3	5, 6, 7, 8, 9
4	4, 5, 6, 7, 8, 9
5	3, 4, 5, 6, 7, 8, 9

In auto filter mode, the average of the last four values entered into the filter is compared to the average of the entire filter. If the difference between the two averages is greater than 12.5%, the contents of the digital filter are set to zero. The filter then starts storing new measurement values, and power meter displays the average of accumulated power readings. This feature shortens the settling time of the power meter when the input power changes substantially.

Only one digit is allowed for MNL FILTER data entries. If a second digit is entered, it replaces the one that is already there. The \square (decimal point) and \pm keys are ignored.

PRESET sets both sensor A and sensor B to auto filter mode.

Related Sections

PRESET
Range
SET A and SET B
STORE and RECALL

Limits

Description

The limits checking function allows the power meter to monitor the power level on each sensor and to indicate when that power is outside preset limits. High and low limits can be set, and the limits checking function is enabled only via remote programming.

Limit values are entered in dBm and need not be the same for each sensor. Allowable values range from -299.999 to $+299.999$ dBm. Values entered outside this range cause the limit to be set to the minimum or maximum value as appropriate.

When the limits checking function is enabled, the power meter uses the last high and low limit values set for each sensor.

Procedure

To set a high limit or a low limit for the active entry channel:

- a. Address the power meter to listen.
- b. Send a program string (in a Data message) consisting of program code LL (limit low) or LH (limit high), a numeric value, and program code EN (ENTER).

To enable the limits checking function, address the power meter to listen and then send a Data message with program code LM1. The limits checking function is disabled by program code LM0.

Example

To set sensor A's low limit to $+10$ dBm and high limit to $+20$ dBm, and to enable the limits checking function:

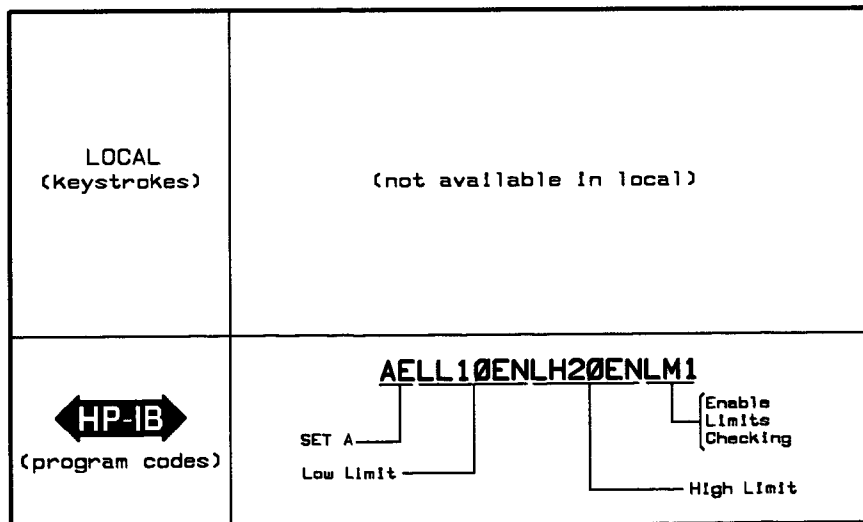

Program Codes

Parameter	Program Code
Low Limit	LL
High Limit	LH
Enable Limits Checking	LM1
Disable Limits checking	LM0

Indications

If the limits checking function is enabled and the input power exceeds the high limit or is less than the low limit, the out-of-limits condition is indicated on the front panel by a flashing A or B annunciator, depending on the measurement mode. The out-of-limits condition is indicated only for sensors used in the current measurement. For dual sensor measurements, the out-of-limits condition is indicated for the sensor(s) out of limits.

The out-of-limits condition can be indicated over the bus by setting the Service Request Mask to enable an out-of-limits condition to issue the Require Service Message, thus lighting the SRQ annunciator on the front panel.

Comments

PRESET sets both the high and low limits for each sensor to 0.000 dBm and disables the limits checking function.

Limits are checked against measured power plus offsets.

By setting the low limit to a value greater than the high limit (or setting the high limit to a value less than the low limit), a region can be defined. An out-of-limits condition occurs anytime displayed power drifts into this region (assuming the limits checking function is enabled).

If the limits checking function is enabled in remote mode and then the Power Meter is switched to local operation, the limits checking function remains enabled.

High and low limits cannot be stored or recalled.

Related Sections

PRESET
 Remote Operation, HP-IB
 SET A and SET B
 STORE and RECALL

Offset

Description

Offset values can be entered to each channel to compensate for gain or loss. The offset is added to the measured power before the result is displayed.

Offsets are entered in dB. The allowable range of values is -99.99 to +99.99dB in 0.01dB increments. Use positive values for gain and negative values for loss. Pressing the **OFFSET** key and then the **ENTER** key (without entering any data) sets the offset of the active entry channel to 0.00dB.

The display offset function provides another method for entering offset values. Pressing **OFFSET**, **DSP → OFS**, and then **ENTER** automatically enters the offset necessary for the power meter's display to indicate 0.00 dB or dBm for logarithmic units, or 100% or 1.00 mW for linear units, depending on the measurement mode. Existing offsets are taken into account in the calculation of the display offset value.

Procedure

To enter an offset for the active entry channel, press **OFFSET**, enter a value between -99.99 and +99.99dB and then press **ENTER**.

To enter the offset necessary for the power meter to display 0.00dB or dBm, 100%, or 1.00 mW (depending on the measurement mode), press **OFFSET**, **DSP→OFS**, and then **ENTER**.

Examples

To add a 20dB offset to channel B (assuming that channel B is the active entry channel):

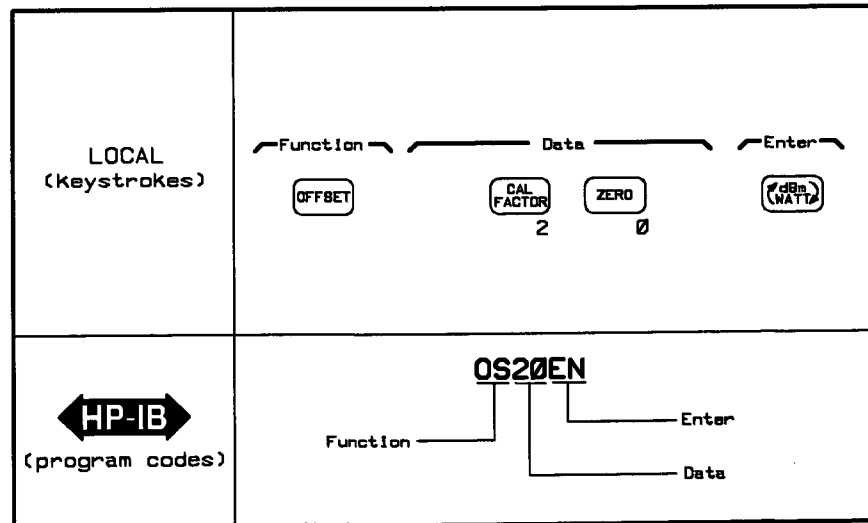

The next example uses the display offset function to compensate for the coupling factor of a directional coupler. Connect sensor A to the

coupler's test port, and connect sensor B to the coupler's incident port. To enter the correct offset for sensor B to read the power emerging from the directional coupler (correcting for any main line insertion loss as well as coupling factor):

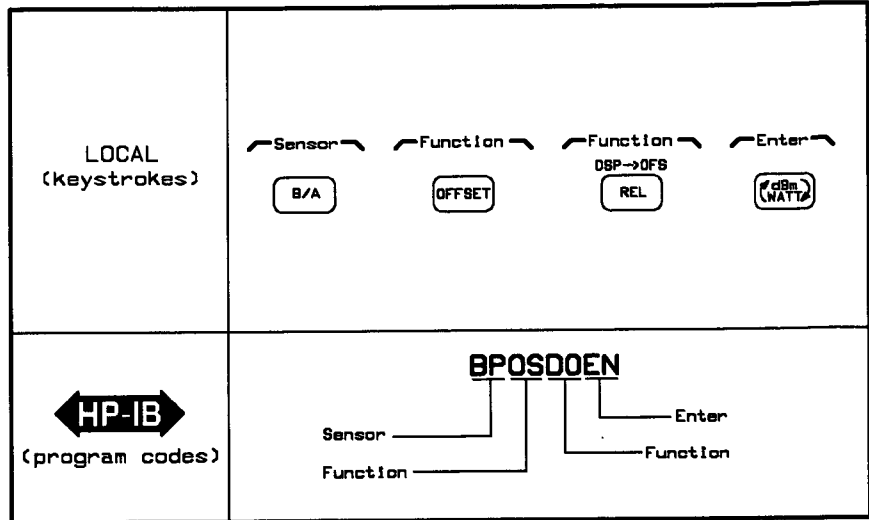

Program Codes

Parameter	Program Code
OFFSET	OS
Display Offset	DO
ENTER	EN

Indications

When an offset is added to a measurement, the front panel displays the value of the offset and the "dBOS" annunciator lights.

Comments

A dB offset can be added to a sensor whose display is in Watts. The power meter automatically converts the dB offset to Watts and adds that value to the sensor's measured power.

The following equations are used to calculate the value that is entered for the display offset function.

For measurement modes A–B or A/B:

Display Offset of active entry channel =

- a. Current OFFSET (active entry channel)

$$- 10 * \text{LOG} \left[\frac{\text{Power}(B) + \text{OFFSET}(B)}{\text{Power}(A) + \text{OFFSET}(A)} \right].$$
- b. Current OFFSET (active entry channel)

$$+ 10 * \text{LOG} \left[\frac{\text{Power}(B) + \text{OFFSET}(B)}{\text{Power}(A) + \text{OFFSET}(A)} \right].$$
- c. Current OFFSET (active entry channel)

$$- 10 * \text{LOG} [\text{Power (active entry channel)}].$$

If the display OFFSET value as calculated above results in an illegal OFFSET entry value, the number 999.9 will be displayed. The power meter generates Error 51 (OFFSET entry error) if an attempt to enter the illegal value is made.

Display offset function ignores REL mode when calculating the offset value.

PRESET sets both the sensor A and sensor B offset values to 0.00dB.

The DSP→OFS function is only active when it is preceded by OFFSET.

Related Sections

dBm/WATT (Logarithmic/Linear Units)
 Error Messages
 PRESET
 REL (Relative Measurements)
 SET A and SET B
 STORE and RECALL

Preset

Description

The **PRESET** key sets the power meter to a known state. Preset conditions are shown in Table 3-9.

Table 3-9. PRESET Conditions

Parameter	Condition
Sensor A and B	
CAL ADJ	100.0%
CAL FACTOR	100.0%
OFFSET	0.00 dB
Filter	AUTO
Range	AUTO
Measurement Mode	Sensor A
Reference Oscillator (OSC)	Off
Active Entry Channel	A
Measurement Units	Watts
REL	Off
Remote Only Functions	
Sensors A and B	
Low Limit	0.000 dBm
High Limit	0.000 dBm
Limits checking	Disabled
Trigger Mode	Free Run
Group Trigger Mode	Trigger with Delay
Display Function	Display Enable

Procedure

To set the power meter to the conditions indicated in Table 3-9, press the **PRESET** key.

Program Codes

The program code for PRESET is PR.

Comments

PRESET does not affect zero and calibration information stored for each sensor. Although PRESET sets the CAL ADJ value to 100.0%, it does not initiate a calibration using the new value for CAL ADJ.

PRESET produces the same results as the Device Clear command over the HP-IB.

Storage register 0 is set to the preset condition when a continuous memory error (Error 57) occurs.

Related Sections

CAL ADJ

CAL FACTOR

dBm/WATT (Logarithmic/Linear Units)

Error Messages

Filters

Limits

OFFSET

Range

REL (Relative Measurements)

STORE and RECALL

Range

(Includes AUTO RANGE and MNL RANGE)

Description

The power meter divides each sensor's power range into 5 ranges of 10dB each. Range 1 is the most sensitive (lowest power levels), and Range 5 is the least sensitive (highest power levels). Range 5 can be less than 10 dB if the sensor's power range is less than 50 dB. The range can be set either automatically or manually for the active entry channel.

AUTO RANGE automatically selects the correct range for the current measurement.

MNL RANGE enables the range to be selected manually. Valid range numbers are 1 through 5. Only one digit is permitted for range entries. If a second digit is entered, it replaces the first digit.

Another feature of the power meter is the hold range mode. Hold range provides a means of switching from auto range to manual range while retaining the current auto range setting.

Procedure

To select auto range, press **AUTO RANGE**. To select manual range, press **MNL RANGE**, enter a numeric value and then press **ENTER**. To select hold range mode, press the **MNL RANGE** key and then the **ENTER** key.

Example

To select range 3 manually:

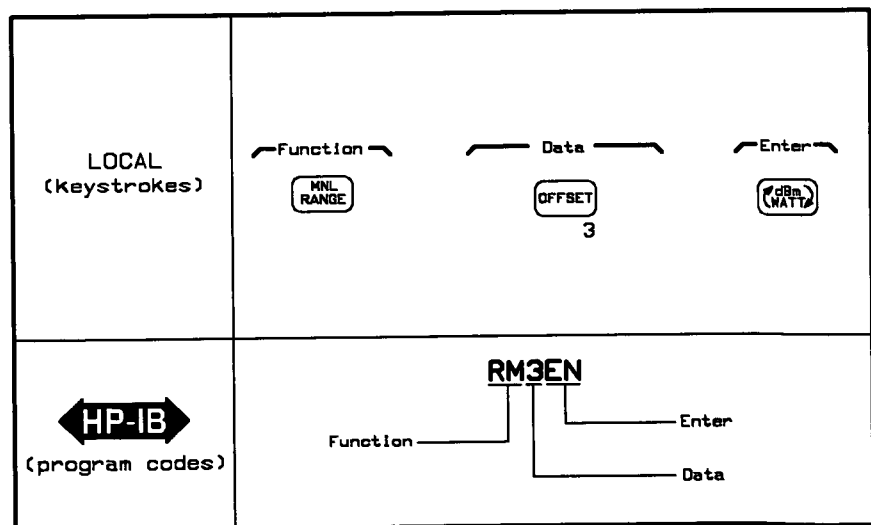

Program Codes

Parameter	Program Code
AUTO RANGE	RA
MNL RANGE	RM
Hold Range	RH
ENTER	EN

Indications

The MNL annunciator on the front panel display lights when the power meter is in manual or hold range mode, or manual or hold filter mode. There is no front panel indication when the power meter is auto ranging.

Comments

PRESET sets both sensor A and sensor B to AUTO RANGE.

If you are only interested in power readings in one range, manual range can be used for faster readings.

Use manual range when using the rear panel RCDR output so that the power meter does not change ranges while outputting data. The recorder output provides a 0 to 1 Vdc output for each range.

Pressing the **AUTO RANGE** key when the power meter is already in auto range mode causes the instrument to step down one range, if possible. (There is a 20% overlap on ranges.) If the power reading can be displayed on either range, the power meter stays on the lower range. In linear mode, this provides a means for down ranging to obtain greater resolution in borderline situations. For example, with an HP 8481A power sensor measuring a power level of 1.153 mW, the range could be either range 4 (1 to 10 mW) or range 3 (0.1 to 1.2 mW with 20% overrange). The display in range 4 would read 1.15 mW, but in range 3 would read 1.153 mW.

Related Sections

- Error Messages
- PRESET
- Recorder Output
- SET A and SET B

Recorder Output

Description

The rear panel RCDR output produces a dc voltage that corresponds to the power level in Watts of sensor A or sensor B, depending on the measurement mode. Only single sensor power measurements produce a valid dc output voltage at the RCDR output. The RCDR output is disabled (OV) during dual sensor and relative measurements. This dc voltage ranges from 0 to +1.0 Vdc. For each of the Power Meter's five ranges, +1.0 Vdc corresponds to a full-scale indication. The output impedance is 1 k*.

Some uses of the RCDR output include recording swept measurements on an X-Y recorder, leveling input for external ALC, or monitoring output power on a strip chart recorder. A setup for recording swept measurements is shown in Figure 3-7.

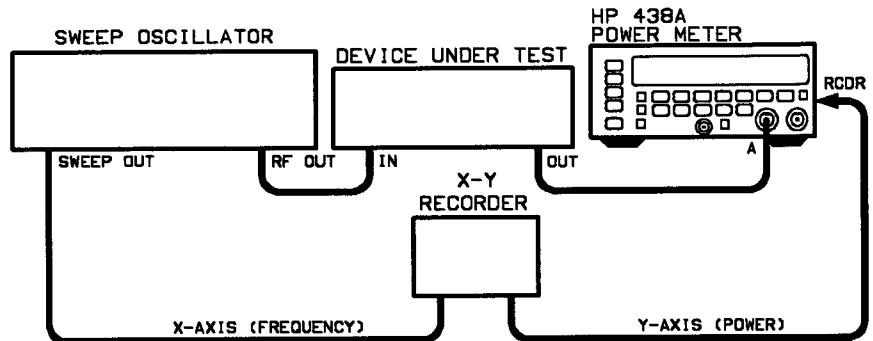

Figure 3-7. Test Setup For Recording Swept Measurements

Comments

Cal factor and offsets have no effect on the recorder output.

The most stable results are obtained on ranges 3, 4, and 5.

Use MNL RANGE when using the RCDR output to prevent the power meter from changing ranges while outputting data.

Related Sections

- Range
- REL (Relative Measurements)
- SENSOR A and SENSOR B

Rel

(Relative Measurements)

Description

Relative mode permits any measurement result to be compared in dB or % to a reference value. Pressing the REL key enters or exits relative mode. Once relative mode has been entered, the first reading is saved as a reference value. Successive measurements are displayed relative to the reference value.

If a new measurement mode is selected while relative mode is enabled, REL is disabled and the reference value is lost.

Procedure

Press **REL** to toggle in and out of relative mode.

Press **dBm/WATT** to alternate between dB and percent.

Example

To enter relative mode and make relative measurements (assuming that the Power Meter is not in relative mode):

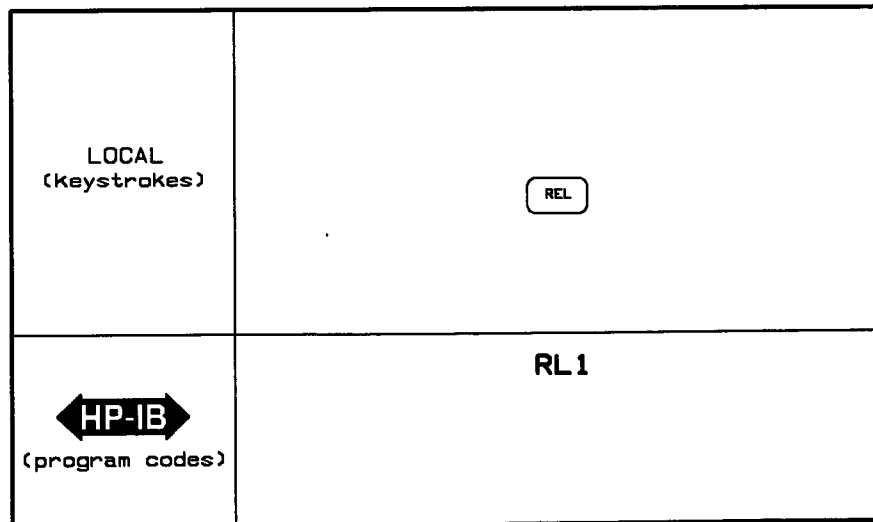

Program Codes

Parameter	Program Code
Enter REL Mode	RL1
Exit REL Mode	RL0

Indications

When the power meter is displaying a relative measurement, the REL annunciator on the front panel display lights. The displayed value is the measurement result relative to the reference in dB or %.

Comments

Relative measurements cannot be output via the rear panel RCDR output.

If the reference is zero or negative power, the measurement result can be displayed in dB as long as the measured power does not change signs (that is, positive to negative or vice versa) while REL mode is on. If the measured power does change signs while displaying dB in REL mode, Error 27 (illegal logarithmic operation) occurs.

If a negative reference is used, the ratio indication (%) will be displayed in absolute value.

The reference value is stored if the power meter is in REL mode when the instrument configuration is saved.

The reference value, once set, cannot be read.

Related Sections

dBm/WATT (Logarithmic/Linear Measurement Units)

SENSOR A and SENSOR B

SENSOR A-B and SENSOR B-A

SENSOR A/B and SENSOR B/A

STORE and RECALL

Sensor A and Sensor B

(Single Sensor Measurements)

Description

SENSOR A and SENSOR B cause the power meter to make single sensor measurements. Absolute power is displayed for the selected sensor in either dBm or Watts. In addition, SENSOR A sets the active entry channel to A, and SENSOR B sets the active entry channel to B.

Procedure

To select a single sensor measurement mode, press **SENSOR A** or **SENSOR B**.

Example

To select SENSOR A as the measurement mode:

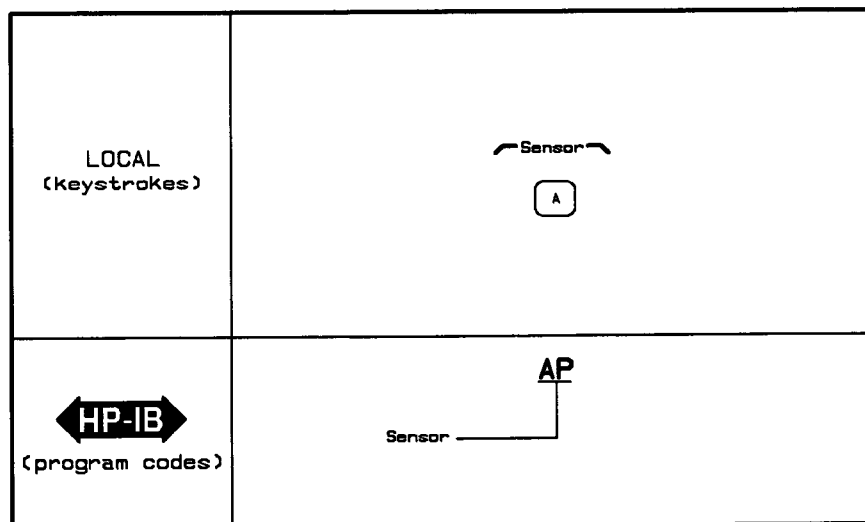

Program Codes

Parameter	Program Code
SENSOR A	AP
SENSOR B	BP

Indications

The middle block of annunciators on the front panel display indicate the measurement mode and the measurement units. The cal factor and offset (if any) for the selected sensor are also indicated in the front panel display.

Comments

Filter, range, offset, cal factor, and limits can be set for the selected sensor.

PRESET sets the measurement mode to SENSOR A.

Single sensor measurements can be displayed relative to a stored reference. In REL mode readings are displayed in either dB or percent.

Changing the measurement mode causes the contents of the digital filter to be discarded.

Related Sections

CAL FACTOR

dBm/WATT (Logarithmic/Linear Units)

Filters

OFFSET

PRESET

Range

REL (Relative Measurements)

SET A and SET B

STORE and RECALL

Sensor A-B and Sensor B-A

(Dual Sensor Difference Measurements)

Description

SENSOR A-B and SENSOR B-A cause the power meter to make dual sensor difference measurements. The power meter displays the numerical difference of the power values of both sensors. The power values for sensors A and B include all offsets and cal factors that have been set for each individual channel. Measurement results are displayed in either dBm or Watts. In addition, A-B sets A as the active entry channel, and B-A sets B as the active entry channel.

Procedure

To make a difference measurement, press the **SHIFT** key and then select A-B or B-A, as desired.

Example

To select B-A measurement mode:

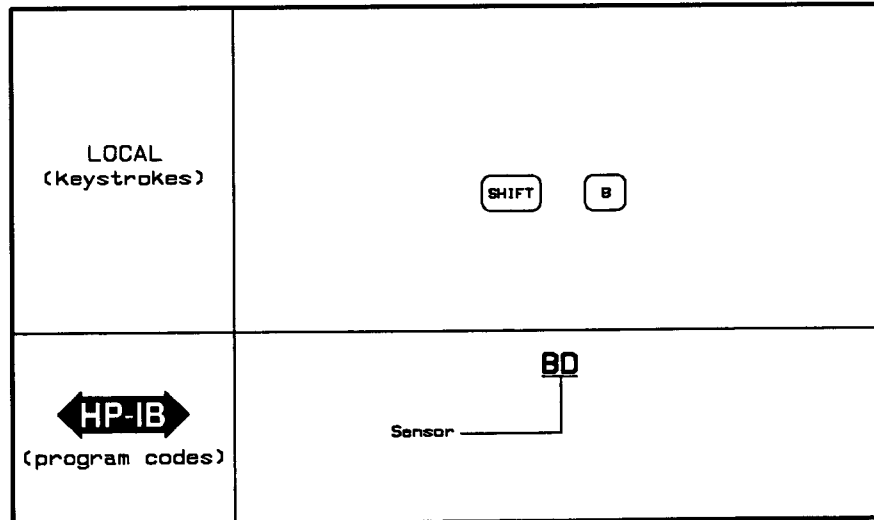

Program Codes

Parameter	Program Code
SENSOR A-B	AD
SENSOR B- A	BD

Indications

The middle block of annunciators on the front panel display indicate the measurement mode (either A–B or B–A) and the measurement units (either dBm or Watts).

Comments

Cal factor, offset, range, limits, and filter are set separately for each sensor.

Logarithmic units (dBm) cannot be used in A–B difference measurements where the sensor A power level is less than the sensor B power level. Likewise, logarithmic units cannot be used in B–A difference measurements where the sensor B power level is less than the sensor A power level.

Difference measurements can be displayed relative to a stored reference. In REL mode, readings are displayed in either dB or percent,

Changing the measurement mode causes the contents of the digital filter to be discarded. The filter buffer then starts filling up with values from the new measurement mode. The power meter displays the average of the accumulated readings.

Related Sections

- Cal Factor
- dBm/Watt (Logarithmic/Linear Measurement Units)
- Filters
- Limits
- OFFSET PRESET
- PRESET
- Range
- REL (Relative Measurements)
- SET A and SET B
- STORE and RECALL

Sensor A/B and Sensor B/A

(Dual Sensor Ratio Measurements)

Description

SENSOR A/B and SENSOR B/A cause the power meter to make dual sensor ratio measurements. The power meter displays the ratio of the sensors' power values in either dB or percent. The power value of each sensor includes offsets and cal factors in addition to measured power. Also, A/B sets A as the active entry channel, and B/A sets B as the active entry channel.

Procedure

To make B/A ratio measurements, press **B/A**. To make A/B ratio measurements, press the **SHIFT** key and then **B/A**.

Example

To make B/A ratio measurements:

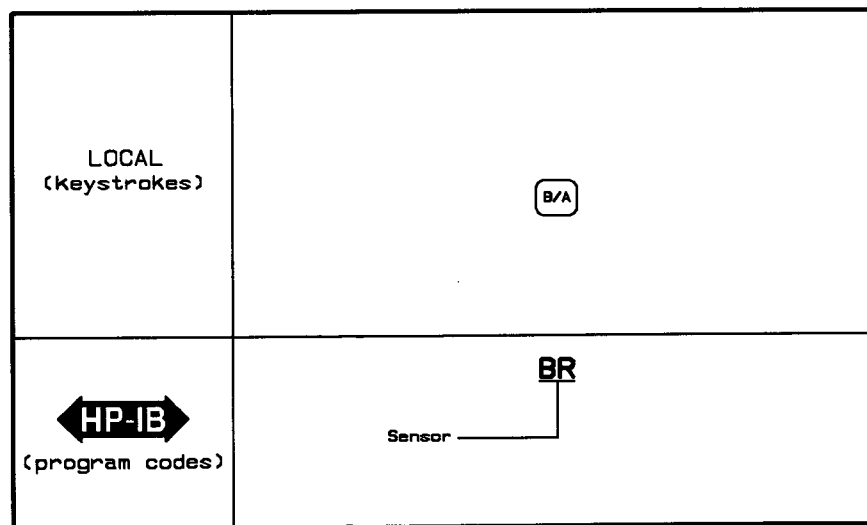

Program Codes

Parameter	Program Code
SENSOR A/B	AR
SENSOR B/A	BR

Indications

The middle block of annunciators on the front panel display indicate the measurement mode (A/B or B/A) and the measurement units (dB or %).

Comments

Cal factor, range, filter, limits, and offset are set separately for each sensor.

Ratio measurements can be displayed relative to a stored reference. In REL mode, readings are displayed in either dB or percent.

Changing the measurement mode causes the contents of the digital filter to be discarded. The filter buffer then starts filling up with values from the new measurement mode. The power meter displays the average of the accumulated readings.

Ratios where the denominator is equal to zero cause Error 27 (log error) to be displayed.

Logarithmic measurement units (dB) cannot be used if the ratio is negative. To do so would cause Error 27 (log error) to be displayed.

Related Sections

CAL FACTOR

dBm/WATT (Logarithmic/Linear Units)

Error Messages

Filters

Limits

OFFSET

Range

REL

SET A and SET B

STORE and RECALL

Set A and Set B

Description

SET A and SET B are used to select the channel on which measurement parameter changes are to be made. Measurement parameters consist of the following:

- Cal Adj (reference calibration factor)
- Cal Factor
- Filters
- Limits
- Offset
- Range
- Zero

SET A and SET B allow measurement parameters to be set for one channel while working in any measurement mode.

Selecting measurement mode SENSOR A, A-B, or A/B automatically sets the active entry channel to channel A. Selecting measurement mode SENSOR B, B-A, or B/A automatically sets the active entry channel to channel B.

Procedure

To select the active entry channel, press **SET A** for channel A or **SET B** for channel B.

Example

To designate channel B as the active entry channel:

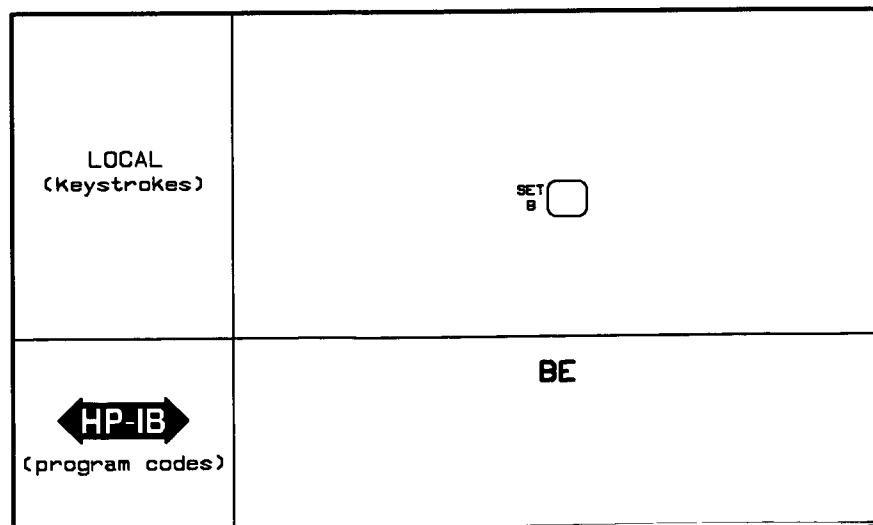

Program Codes

Parameter	Program Code
SET A	AE
SET B	BE

Indications

When a measurement parameter is being entered, an annunciator on the right side of the display lights to indicate the active entry channel.

Comments

PRESET sets the active entry channel to A.

Related Sections

CAL ADJ
Cal Factor
Filters
Limits
OFFSET
PRESET
Range
SENSOR A and SENSOR B
SENSOR A-B and SENSOR B-A
SENSOR A/B and SENSOR B/A

Store and Recall

Description

The power meter can store instrument configurations for recall at a later time. The following information can be stored in the power meter's internal registers:

- Measurement Mode
- REL mode status (on or off)
- Reference value if in REL mode
- Reference Oscillator status (on or off)
- Active entry channel (A or B)
- Measurement units (logarithmic or linear)
- Cal factor for each sensor
- Offset for each sensor
- Range for each sensor
- Filter for each sensor
- Cal Adj value for each sensor

Registers 1 through 19 are available for storing instrument configurations. Registers 0 through 19 are available for recall. Register 0 always contains the previous power meter configuration. Thus, RECALL 0 provides a way to recover from an entry error.

Procedure

To store an instrument configuration, press **STORE**, enter a number from 1 to 19, and then press **ENTER**.

To recall an instrument configuration, press **RECALL**, enter a number from 0 to 19, and then press **ENTER**.

Example

To recall an instrument configuration that has been stored in register 2:

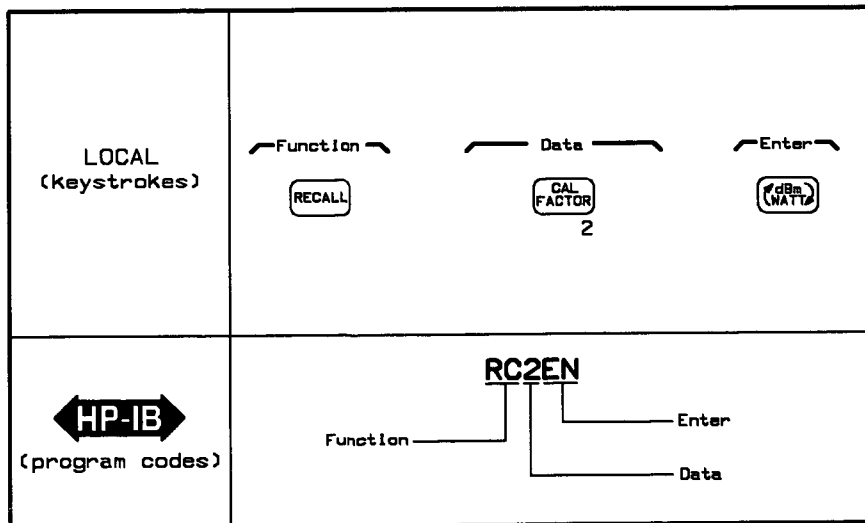

Program Codes

Parameter	Program Code
RECALL	RC
STORE	ST
ENTER	EN

Indications

When the stored contents of a register are recalled, the power meter changes to the recalled parameter values.

The power meter executes a RECALL 0 at power-up. This places the power meter in the same state that it was in when power was removed.

The Cal Adj value (reference calibration factor) for each sensor can be stored and recalled but the internal calibration settings are not stored.

PRESET has no effect on the storage registers 1 through 19. Register 0, however, is set to the PRESET conditions when the **PRESET** key is pressed.

Storage register 0 is set to the PRESET state when a continuous memory error (Error 57) occurs.

High and low limits cannot be stored.

Related Sections

- CAL ADJ
- CAL FACTOR
- dBm/WATT (Logarithmic/Linear Units)
- Error Messages
- Filters
- Limits
- OFFSET
- PRESET
- Range
- REL (Relative Measurements)
- SET A and SET B

Zero

Description

ZERO is used to adjust the power meter's internal circuitry for a 0 power indication when no power is applied to the sensor. Pressing the **ZERO** key automatically zeroes all five of the power meter's ranges. For dual sensor measurements, each channel of the power meter must be zeroed separately.

Note



Be sure that no power is applied to the sensor while the power meter is zeroing. Any applied RF input power introduces an offset that affects all subsequent measurements.

Procedure

To zero the power meter to the sensor connected to the active entry channel, press **ZERO**.

Example

To zero the power meter:

<p>LOCAL (keystrokes)</p>	<p>ZERO</p>
<p>HP-IB (program codes)</p>	<p>ZE</p>

Program Codes

Parameter	Program Code
ZERO	ZE

Indications

The power meter display shows eight dashes and a moving decimal point while zeroing. When the zeroing is completed, new zero values are stored and the instrument is returned to its previous state.

Comments

Zero the power meter before entering the reference calibration factor.

The power meter's internal reference oscillator automatically turns off during zeroing. If the reference oscillator was on before the zeroing was initiated it will be returned to the on state when zeroing is completed.

To determine whether or not the power meter needs to be zeroed, remove any power to the sensor and then read the front panel display. If the display does not indicate 0 power, the power meter needs to be zeroed. Any residual nonzero reading, if not corrected, will be added to all subsequent measurements, resulting in an error. This error may be insignificant when measuring moderate to high power values, but it can be unacceptable when measuring low power values.

Error 57 (recall fail) occurs when the power meter is turned on and the internal RAM contents have been lost. This is generally due to battery failure but may also occur when the instrument is powered down while zeroing.

For best accuracy, HP 8484A Power Sensors should be connected to a device with the RF power off before zeroing.

Zeroing data cannot be stored and recalled, but it is remembered when the instrument is turned off.

PLEASE 0 (Error 15 or 16, sensor dependent) is displayed when the zero reference drifts negative.

Related Sections

- CAL ADJ
- Error Messages
- Range
- STORE and RECALL



Performance Tests

4-1. Introduction

The procedures in this section test the instrument's electrical performance using the specifications of Table 1-1 as the performance standards. All tests can be performed without access to the interior of the instrument. A simpler operational test is included in section 3 under "Basic Functional Checks".

Note



If the performance tests are to be considered valid, the following conditions must be met:

- a. The power meter must have a 1 hour warm-up for all specifications.
 - b. The line voltage for all instruments must be 100, 120, 220, or 240 Vac +5%, -10%; and the line frequency must be 48 to 66 Hz. The power meter has the additional capability of operating on line frequencies of 360 to 440 Hz, but the line voltage is limited to a nominal 100 or 120 Vac.
 - c. The ambient temperature must be 0°C to 55°C.
-

4-2. Equipment Required

Equipment required for the performance tests is listed in Table 1-3, "Recommended Test Equipment". Any equipment that satisfies the critical specifications given in the table may be substituted.

4-3. Performance Test Record

Results of the performance test may be tabulated in Table 4-1, Performance Test Record. The Performance Test Record lists all of the performance test specifications and the acceptable limits for each specification. If performance test results are recorded during an incoming inspection of the instrument, they can be used for comparison during periodic maintenance or troubleshooting procedures. The test results may also prove useful in verifying proper adjustments after repairs are made.

4-4. Performance Tests

The performance tests given in this section are suitable for incoming inspection, troubleshooting, or preventive maintenance. During any performance test, all shields and connecting hardware must be in place. The tests are designed to verify published instrument specifications. Perform the tests in the order given and record the data on the test card and/or in the data spaces provided at the end of each procedure.

4-5. Calibration Cycle

This instrument requires periodic verification of performance to ensure that it is operating within specified tolerances. The performance tests described in this section should be performed at least once each year; under conditions of heavy usage or severe operating environments, the tests should be more frequent. Adjustments that may be required are described in section 5, "Adjustments".

**4-6. Abbreviated
Performance Test**

Refer to section 3, "Operation", for a Basic Functional Checks test.

4-7. Test Procedures

It is assumed that the person performing the following tests understands how to operate the specified test equipment. Equipment settings, other than those for the power meter, are stated in general terms. It is also assumed that the technician will select the power sensor, cables, adapters and probes required for test setups illustrated in this section.

4-8. Zero Carryover Test

Specification

Electrical Characteristics	Performance Limits	Conditions
Accuracy: Zero set (Digital settability of zero)	$\pm 0.5\%$ full scale	Most sensitive range. Decrease percentage by factor of 10 for each higher range ± 1 count.

Description

After the power meter is initially zeroed, the change in the digital readout is monitored as the power meter is stepped through its ranges. This test also takes drift and noise into account, since drift, noise and zero carryover readings cannot be separated.

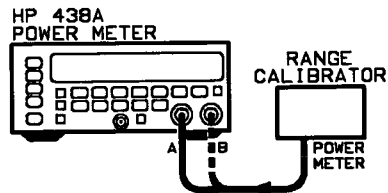

Figure 4-1. Zero Carryover Test Setup

- Equipment**
- Range HP 11683A
 - Power Sensor HP 11730A

Procedure

1. Connect the equipment as shown in Figure 4-1.
2. Set the power meter controls as follows:
 - LINE ON
 - PRESS PRESET
3. Set the range calibrator switches as follows:
 - FUNCTION STANDBY
 - LINE ON
4. Press the power meter's **ZERO** switch and wait (approximately 15 to 17 seconds) for the display to reappear and stabilize. Verify that the reading is 0.00 ± 0.06 .

Note

The power meter is now zeroed on range 1 (most sensitive).

5. Press **MNL RANGE**, **1**, **ENTER**.
6. After the power meter reading has stabilized, verify that the indication is within the limits shown.

Power Meter Range	Min	Actual Results A	Actual Results B	Max
1	-0.06 μ W	_____	_____	0.06 μ W
2	-0.1 μ W	_____	_____	0.1 μ W
3	-0.001 mW	_____	_____	0.001 mW
4	-0.01 mW	_____	_____	0.01 mW
5	-0.1 mW	_____	_____	0.1 mW

7. Repeat steps 5 and 6 by entering **2**, then **3**, then **4**, and **5**.
8. Repeat steps 2 through 7 for Channel B by pressing **B** in step 2.
9. Repeat steps 2 through 7 for Channel A and B when rear panel Option 002 inputs are installed.

4-9. Instrument Accuracy Test

Specification

Electrical Characteristics	Performance Limits	Conditions
Accuracy: Instrumentation, includes sensor linearity. ¹		
Single channel mode	$\pm 0.2\%$ Plus ± 0.02 dB	Within same calibration range Outside calibration range
Dual channel mode (Ratio or difference)	Multiply single channel specification by 2	

¹ When operating in ranges 5 add the corresponding sensor power linearity percentage.

Description

After the power meter is initially calibrated on the 1 mW range, the readout is monitored as the range calibrator is switched to provide reference inputs corresponding to each of the power meter operating ranges.

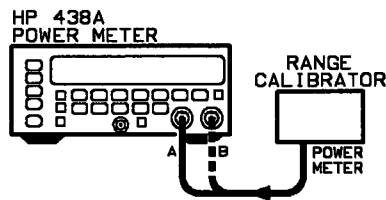

Figure 4-2. Instrument Accuracy Test Setup

Equipment

Range Calibrator HP 11683A
 Power Sensor Cable HP 11730A

Procedure

1. Connect the equipment as shown in Figure 4-2.
2. Set the power meter controls as follows:

LINE ON
 SENSOR A
 PRESS PRESET

3. Set the range calibrator switches as follows:

FUNCTIONSTANDBY
 POLARITYNORMAL
 RANGE 1 mW
 LINE ON

4. Press the power meter **ZERO** key, and wait for the readout to reappear. Verify that the reading is $0.00 \pm 0.06 \mu\text{W}$.
5. Set the range calibrator FUNCTION switch to CALIBRATE.
6. Press the power meter **CAL ADJ** key, then press the **±** key to get a minus (-) sign, then press **100**, **ENTER**. The minus sign indicates use of an external reference source. If the minus sign is not used there will be a NO REF error on the display.
7. Verify that the power meter display reads $1.000 \pm 0.006 \text{ mW}$.

Note



The range calibrator output level is adjustable in 5dB increments. Thus, the 3 μW , 30 μW , 300 μW , 3 mW, and 30 mW legends on the RANGE switch are approximations. The true values for these settings are 3.16, 31.6, and 316 μW , 3.16 mW and 31.6 mW. It may be necessary to re-zero the meter before each measurement.

8. Set the range calibrator RANGE switch to the positions shown in the following table. For each setting, verify that the power meter autoranges properly, and that the display is within the limits shown.
9. Set the range calibrator RANGE switch to STANDBY. Connect the calibrator to channel B.
10. Press the power meter channel **k** and repeat steps 4 through 6 to test channel B.
11. Set the power meter dBm/WATT switch to the dBm position and verify that the display changes to the dBm mode, and that the indication is within $20.00 \pm 0.04 \text{ dBm}$.

19.96 dBm _____ 20.04 dBm

12. Set the range calibrator RANGE switch to -10 dBm.
13. Verify that the power meter displays $-10.00 \pm 0.04 \text{ dBm}$.

-9.96 dBm _____ -10.04 dBm

14. Press the power meter **REL** key and verify that the display indicates $0.00 \pm 0.01 \text{ dB}$.

Range Calibrator Setting	Min	Actual Results	Max
3 μ W	3.13 μ W	_____	3.19 μ W
10 μ W	9.90 μ W	_____	10.10 μ W
30 μ W	31.3 μ W	_____	31.9 μ W
100 μ W	99.0 μ W	_____	101.0 μ W
300 μ W	0.314 mW	_____	0.318 mW
1 mW	0.995 mW	_____	1.005 mW
3 mW	3.13 mW	_____	3.19 mW
10 mW	9.90 mW	_____	10.10 mW
30 mW	31.3 mW	_____	31.9 mW
100 mW	99.0 mW	_____	101.0 mW

Note



It is not necessary to check instrument accuracy in dBm. The power meter uses the same internal circuitry to measure power and mathematically converts watts to dBm.

20 μ w

4-10. Power Reference Level Test

Specification

Electrical Characteristics	Performance Limits	Characteristics
Power reference	1.0 mW	Internal 50 MHz oscillator factory set to $\pm 0.7\%$ traceable to National Bureau of Standards.
Power reference Accuracy	$\pm 1.2\%$ $\pm 0.9\%$	Worst case. RSS for one year.

Description

The power reference oscillator output is factory adjusted to 1 mW $\pm 0.7\%$. To achieve this accuracy, Hewlett-Packard employs a special measurement system accurate to 0.5% (traceable to the National Bureau of Standards) and allows for a transfer error of $\pm 0.2\%$ in making the adjustment. If an equivalent measurement system is employed for verification, the power reference oscillator output can be verified to 1 mW $\pm 1.9\%$ ($\pm 1.2\%$ accuracy plus $\pm 0.5\%$ verification system error plus $\pm 0.2\%$ transfer error = 1.9% maximum error). The power reference oscillator can be set to $\pm 0.7\%$ using the same equipment and following the adjustment procedure. To ensure maximum accuracy in verifying the power reference oscillator output, the following procedure provides step by step instructions for using specified Hewlett-Packard test instruments of known capability. If equivalent test instruments are used, signal acquisition criteria may vary and reference should be made to the manufacturer's guidelines for operating the instruments.

Note



The power meter may be returned to the nearest Hewlett-Packard office to have the power reference oscillator checked and/or adjusted. Refer to section 2, "Packaging".

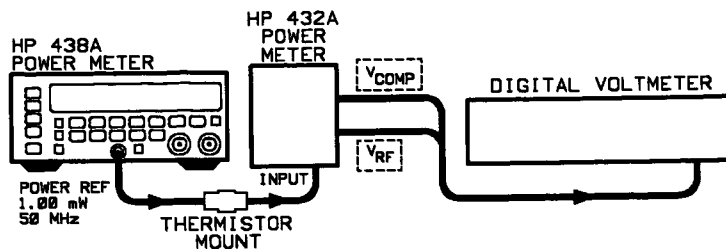

Figure 4-3. Power Reference Level Test Setup

Equipment	Test Power Meter	HP 432A
	Thermistor Mount	HP 478A Option H75/H76
	Digital Voltmeter (DVM)	HP 3456A

- Procedure**
1. Set the DVM to measure resistance. Connect the DVM between the Vrf connector on the rear panel of the test power meter, and pin 1 on the thermistor mount end of the test power meter interconnect cable.
 2. Round the DVM reading to two decimal places. Record this value as the internal bridge resistance (R) of the test power meter (approximately 200 ohms).

R. _____

3. Connect the test power meter to the power meter as shown in Figure 4-3.
4. Set the power meter LINE switch to ON and the OSC switch off (LED off).

Note



Wait thirty minutes for the test power meter thermistor mount to stabilize before proceeding to the next step.

5. Set the test power meter RANGE switch to Coarse Zero and adjust the front panel Coarse Zero control to obtain a zero meter indication.
6. Fine Zero the test power meter on the most sensitive range, then set the test power meter RANGE switch to 1 mW.

Note



Ensure that DVM input leads are isolated from chassis ground when performing the next step.

7. Set the DVM to measure microvolts. Connect the positive and negative input leads, respectively, to the Vcomp and Vrf connectors on the rear panel of the test power meter.

8. Observe the reading on the DVM. If less than 400 microvolts, proceed to the next step. If 400 microvolts or greater, press and hold the test power meter Fine Zero switch and adjust the Coarse Zero control so that the DVM indicates 200 microvolts or less. Then release the Fine Zero switch and proceed to the next step.
9. Round the DVM reading to the nearest microvolt. Record this value as V0.

V0_____

10. Set the power meter OSC switch to ON (LED on). Record the reading observed on the DVM as V1.

V1_____

11. Disconnect the DVM negative input lead from the Vrf connector on the test power meter. Reconnect it to test power meter chassis ground.

Observe the DVM reading. Record the reading as Vcomp.

V comp_____

12. Calculate the power reference oscillator output level (Prf) from the following formula:

$$Prf = \frac{2V_{comp}(V_1 - V_0) + V_0^2 - V_1^2}{4R(CalibrationFactor)}$$

Where:

Prf=power reference oscillator output level

Vcomp=previously recorded value

V1=previously recorded value

V0=previously recorded value

R=previously recorded value

Calibration Factor=value for thermistor mount at 50 MHz (traceable to the National Bureau of Standards).

13. Verify that Prf is within the limits shown in the following table. Record the reading.

Min	Actual	Max
0.988 mW	_____	1.012 mW

Table 4-1. Performance Test Record

Hewlett-Packard Company

Tested by _____

Model HP 438A
Power Meter

Serial Number _____ Date _____

Paragraph Number	Test	Minimum Result	Actual Result	Maximum Result
4-8.	Zero Carryover			
	Power Meter Range			
	1	-0.06 μ W	_____	0.06 μ W
	2	-0.1 μ W	_____	0.1 μ W
	3	-0.001mW	_____	0.001 mW
	4	-0.01 mW	_____	0.01 mW
4-9.	Instrument Accuracy			
	Watt Mode			
	3 μ W	3.13 μ W	_____	3.19 μ W
	10 μ W	9.90 μ W	_____	10.10 μ W
	30 μ W	31.3 μ W	_____	31.9 μ W
	100 μ W	99.0 μ W	_____	101.0 μ W
	300 μ W	0.313 mW	_____	0.319 mW
	1 mW	0.995 mW	_____	1.005 mW
	3 mW	3.13 mW	_____	3.19 mW
	10 mW	9.90 mW	_____	10.10 mW
	30 mW	31.3 mW	_____	31.9 mW
	100 mW	99.0 mW	_____	101.0 mW
	dBm Mode			
	20 dBm	19.96 dBm	_____	20.04 dBm
	-10 dBm	-9.96 dBm	_____	-10.04 dBm
Rel Mode	-0.01 dBm	_____	+0.01 dBm	
4-10.	Power Reference			
Prf	0.988 mW	_____	1.012 mW	



Adjustments

5-1. Introduction

This section contains adjustments and checks that ensure proper performance of the power meter. Adjustments are not required on any fixed periodic basis, and normally are performed only after a performance test has indicated that some parameters are out of specification. Performance tests should be completed after any repairs that may have altered the characteristics of the instrument. The test results will make it possible to determine whether or not adjustments are required. Allow 60 minutes for the power meter to warm up, and then remove the top and bottom covers, also loosen the screws holding the A3 CPU Assembly and A5 Main Amplifier Assembly for access to the test and adjustment points.

To determine which performance tests and adjustments to perform after a repair, refer to paragraph "5-6. Post-Repair Adjustments".

5-2. Safety Considerations

This section contains a warning that must be followed for your protection and to avoid damage to the equipment being used.

Warning



Adjustments described in this section are performed with power applied to the instrument and with protective covers removed. Maintenance should be performed only by trained personnel who are aware of the hazards involved. When the maintenance procedure can be performed without power, the power should be removed.

5-3. Equipment Required

Most of the adjustment procedures include a list of recommended test equipment, and the test equipment is also identified on the test setup diagrams. If substitutions must be made, the equipment used must meet the critical specification listed in Table 1-3 in section 1.

5-4. Factory Selected Components

Factory selected components are identified on the schematics and parts lists by an asterisk(*) which follows the reference designator. The nominal value of the selected component is shown. Table 5-1 lists the reference designator, the service sheet where the component is shown, the value range, and the basis for selecting a particular value.

5-5. Interrelated Adjustments

The -15V adjustment on the A9 Regulator Assembly should be the first item checked during any adjustment procedure. The -15V source and the $+15\text{V}$ source are such that they are equal but opposite in sign. The $+5\text{V}$ (D) digital is measured and adjusted second before the other adjustment procedures are started.

Note

Make adjustments only in the order specified.

5-6. Post-Repair Adjustments

Table 5-2 lists the adjustments related to repairs or replacement of any of the assemblies.

Table 5-1. Factory Selected Components

Reference Designator	Service Sheet	Range of Values	Basis of Selection
G1A1R2 G1A1VR2 combination (G2A1R2 G2A1VR2 Option 002)	11	825 Ω with 5.11 V Zener or 1470 Ω with 8.25 V Zener	If the reference power is outside the range of 1.000 ± 0.0007 mW between 0°C and 55°C , and if the G1A1R2, G1A2VR2 combination is 825 Ω 5.11 V then change the G1A1R2, G1A1VR2 combination to 1470 Ω 8.25 V. However, if the G1A1R2, G1A1VR2 combination is already 1470 Ω 8.25 V, then a problem exists elsewhere.

Table 5-2. Post-Repair Adjustments, Tests, and Checks

Assembly Repaired	Related Adjustment or Performance Test	Reference Service Sheet
A1 Keyboard	None	1
A2 Display	None	5
A3 Central Processing Unit	5-7, 5-8, 5-9	1, 2, 3, 4
A4 Input Amplifier	5-7, 5-8, 5-10, 5-11	6
AS Main Amplifier	5-7, 5-8, 5-9	7, 8
A8 Rectifier	4-10, 4-11, 4-12, 4-13, 5-7, 5-8	9
A9 Regulator	4-8, 4-9, 5-7, 5-8	9, 10
G1 50 MHz Reference Oscillator	5-7, 5-8, 5-12, 5-13	11

5-7. ±15 Volt Power Supply Adjustment

Reference Service Sheet 10

Description The +15 volt supply is measured, then the -15 volt supply is measured and adjusted so that the supplies are equal in amplitude but of opposite sign.

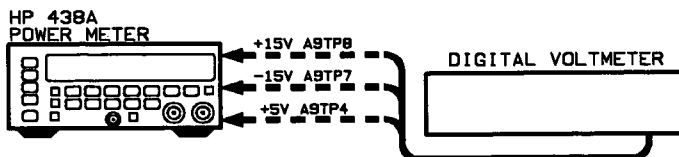

Figure 5-1. Power Supply Adjustments Setup

Equipment Digital Voltmeter (DVM) HP 3456A

- Procedure**
1. Remove the top and bottom covers of the power meter. Loosen the screws that secure the A3 CPU Assembly. Turn the instrument ON and allow for warm-up.
 2. Connect the DVM between the +15V testpoint A9TP8 and chassis ground. Measure and record the value of the +15 volts. The voltage should be between 14.25 and 15.75 Vdc.

+15 V _____

3. Connect the DVM between the -15V testpoint A9TP7 and chassis ground. Adjust -15V, A9R16, until the DVM reading is within 0.05 Vdc of the numerical value from step 2. Ignore the difference in sign for this adjustment.

5-8. +5 Volt Power Supply Adjustment

Reference Service Sheet 9

Description The +5 volt supply is measured and adjusted.

Equipment Digital Voltmeter (DVM) HP 3456A

Procedure 1. See Figure 5-1. Connect the DVM between the +5V testpoint A9TP4 and ground. Adjust +5V, A9F3 until the DVM reads 5.00 ±0.05 volts.

5-9. Analog to Digital Converter Slope Adjustment

Reference Service Sheet 8

Description The Analog to Digital Converter is adjusted for a central reading.

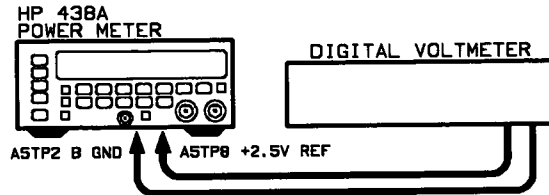

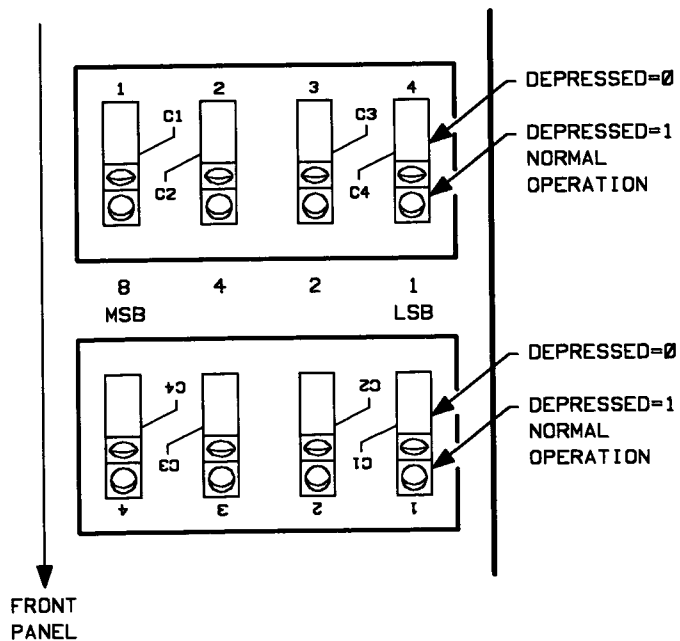

Figure 5-2. Analog to Digital Converter Slope Adjustment Setup

Equipment Digital Voltmeter (DVM) HP 3456A

Procedure 1. Turn the power meter OFF. Place all 4 switches of A3S1 to the test position. This would be positions where the switches are all opposite to the normal operating position.

Note  A3S1 can be loaded on the printed circuit board so that it has one of the two orientations shown.



2. Turn the power meter ON. The instrument should now display
-- -- -- -- --. Connect the DVM between B-GND A5TP2 and
+2.5V REF A5TP8 testpoints on A5. Read the DVM.

3. Enter the reading to 5 digits (4 decimal places) into the power meter
by entering the numbers into the keyboard, then pressing **ENTER**.
4. Adjust the ADC SLOPE, A5R61, so that the display reading is
centered about zero. (The reading may be from +5.00 to -5.00, try
to get as close to zero as possible.)
5. Turn the power meter OFF. Return A3S1 to its original position.

5-10. 220 Hz Frequency Adjustment

Reference Service Sheet 6

Description The 220 Hz is adjusted for maximum power meter readout.

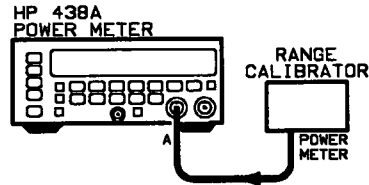

Figure 5-3. 220 Hz Frequency Adjustment Setup

Equipment Range Calibrator HP 11683A

Procedure

1. Turn both the power meter and the range calibrator ON. Set the range calibrator controls as follows:

LINE ON
 RANGE 1 mW
 FUNCTION STANDBY
 POLARITY NORMAL

2. Connect the range calibrator output to channel A using the sensor cable. Press **PRESET** on the power meter then press **ZERO**, and allow time (approximately 15 to 17 seconds) for the power meter zeroing process.
3. Set the range calibrator function switch to calibrate.
4. On the power meter press **CAL ADJ**, **-**, **100**, then **ENTER**. This procedure allows the power meter to calibrate using an external reference, the range calibrator output.
5. Adjust 220 Hz, A4R43, for the maximum front panel reading.

5-11. Ranges 4 and 5 Shaper Adjustment, Channel A and B

Reference Service Sheet 6

Description Ranges 4 and 5 Shaper circuits are adjusted for proper gain.

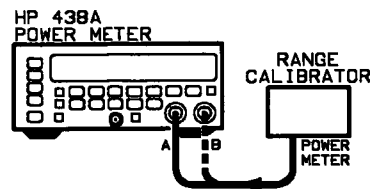

Figure 5-4. Ranges 4 and 5 Shaper Adjustment Setup

Equipment Range Calibrator HP 11683A

Procedure

1. Connect range calibrator to channel A input connector.
2. Set the range calibrator controls as follows:

LINE	ON
RANGE	1 mW
FUNCTION	STANDBY
POLARITY	NORMAL
3. Turn the power meter ON. Press **PRESET**. After zeroing the power meter, set the range calibrator to calibrate, then press **CAL ADJ**, **100**, and **ENTER** on the power meter.
4. Set the range calibrator range to 10 mW.
5. Adjust RNG 4, A4R26, until the power meter reads 10.00 ± 0.01 mW.
6. Set the range calibrator range to 100 mW.
7. Adjust RNG 5, A4R34, until the power meter reads 100.0 ± 0.1 mW.
8. Repeat steps 4 through 7 to check that interaction between steps has not caused a shift in settings.
9. Repeat the procedure for channel B of the power meter by making connection to channel B from the range calibrator.
10. Repeat the above procedure, starting with step 3, except press **B** on the power meter. Adjust RNG 4 SHP, A4R27, and RNG 5 SHP, A4R35, as in steps 5 and 7 above.

5-12. Power Reference Oscillator Frequency Adjustment

Note



Adjustment of the Power Reference Oscillator frequency may also affect the output level of the oscillator. Thus after the frequency is adjusted 50.0 ± 0.5 MHz, the output level should be checked as described in section 4. A procedure for adjusting the output to the specified level is provided in the next paragraph.

Reference

Service Sheet 11

Description

Variable inductor G1A1L1 is adjusted to set the power reference oscillator output frequency to 50.0 ± 0.5 MHz.

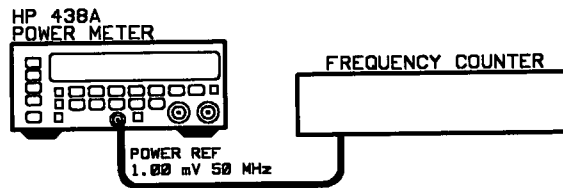

Figure 5-5. Power Reference Oscillator Frequency Adjustment Setup

Equipment

Frequency Counter HP 5328A Option 031

Procedure

1. Connect the equipment as shown in Figure 5-5 and set up the counter to measure frequency.
2. Set the power meter LINE switch to ON (in) and the POWER REF OSC switch to off (LED off).
3. Set the power meter POWER REF OSC switch to on (LED on) and observe the indication on the counter. If the counter display reads 50.0 ± 0.5 MHz, no adjustment of the power reference oscillator frequency is necessary. If it is not within these limits, adjust the power reference oscillator frequency as described in steps 4 and 5.
4. Remove the power meter top cover, and loosen the screws holding the A3 CPU Assembly. Swing the assembly out. The screwdriver adjustment is accessible through a hole in the deck.
5. Adjust G1A1L1 to obtain a 50.00 ± 0.5 MHz indication on the counter.

5-13. Power Reference Oscillator Level Adjustment

Reference Service Sheet 11

Description The power reference oscillator is factory-adjusted to $1.0 \text{ mW} \pm 0.7\%$ using a special measurement system accurate to 0.5% (traceable to the National Institute of Standards and Technology) and allowing for a 0.2% transfer error. To ensure maximum accuracy in readjusting the power reference oscillator, the following procedure provides step-by-step instructions for using specified Hewlett-Packard instruments of known capability. If equivalent instruments are used, signal acquisition criteria may vary and reference should be made to the manufacturer's guidelines for operating the equipment.

Note



The power meter may be returned to the nearest HP office to have the power reference oscillator checked and/or adjusted. Refer to section 2, "Packaging".

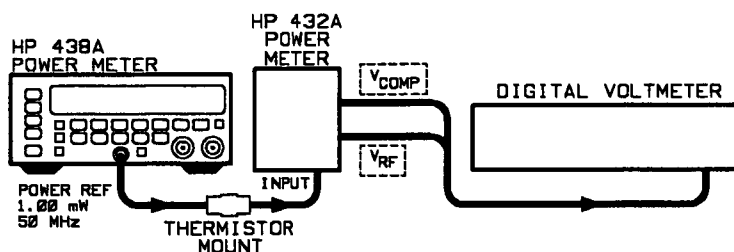

Figure 5-6. Power Reference Oscillator Level Adjustment Setup

Equipment

Test Power Meter	HP 432A
Thermistor Mount	HP 478A-H75/H76
Digital Voltmeter (DVM)	HP 3456A

- Procedure**
1. Set the DVM to measure resistance and connect the DVM between the Vrf connector on the rear panel of the test power meter and pin 1 on the thermistor mount end of the test power meter interconnect cable.
 2. Round the DVM reading to two decimal places. Record this value as the internal bridge resistance (R) of the test power meter (approximately 200 ohms).

R (Internal Bridge Resistance) _____

3. Connect the test power meter to the power meter as shown in Figure 5-5.

4. Set the power meter LINE switch to ON and the POWER REF OSC switch to OFF. Wait thirty minutes for the test power meter thermistor mount to stabilize before proceeding to the next step.
5. Set the test power meter range switch to coarse zero. Adjust the front panel coarse zero control to obtain a zero meter indication.
6. Fine zero the test power meter on the most sensitive range, then set the test power meter range switch to 1 mW.

Note

Ensure that the DVM input leads are isolated from chassis ground when performing the next step.

7. Set the DVM to measure microvolts. Connect the positive and negative input leads, respectively, to the Vcomp and Vrf connectors on the rear panel of the test power meter.
8. Observe the reading on the DVM. If less than 400 microvolts, proceed to the next step. If 400 microvolts or greater, press and hold the test power meter fine zero switch and adjust the coarse zero control so that the DVM reads 200 microvolts or less. Then release the fine zero switch and proceed to the next step.
9. Round the DVM reading to the nearest microvolt. Record this value as V0.

V0_____

10. Disconnect the DVM negative input lead from the Vrf connector on the test power meter. Reconnect the lead to chassis ground.
11. Set the power meter POWER REF OSC to ON. Record the reading observed on the DVM as Vcomp.

Vcomp_____

12. Disconnect the DVM negative input lead from chassis ground. Reconnect it to the Vrf connector on the rear panel of the test power meter. The DVM is now set up to measure V1 which represents the power reference oscillator output level.
13. Calculate the value of V1 equal to 1 mW from the following equation:

$$V_1 - V_0 = V_{COMP} - \sqrt{(V_{COMP})^2 - (10^{-3})(4R)(EFFECTIVE\ EFFICIENCY)}$$

Where:

V_0 = previously recorded value

V_{COMP} = previously recorded value

10^{-3} = 1 milliwatt

R = previously recorded value

EFFECTIVE EFFICIENCY = value for thermister mount at 50 MHz (traceable to the National Institute of Standards and Technology).

14. Remove the power meter top cover and adjust the LEVEL ADJUST potentiometer G1A1R4 so that the DVM reads the calculated value of V_1 .

Typical Calculations

1. ACCURACY:

DVM Measurements:	$(V_{COMP}) \pm 0.018\%$
	$(V_1 - V_0) \pm 0.023\%$
	$(R) \pm 0.03\%$
Math Assumptions:	$\pm 0.01\%$
EFFECTIVE EFFICIENCY CAL (NIST):	$\pm 0.5\%$
MISMATCH UNCERTAINTY:	$\pm 0.1\%$
(Source & Mount SWR ≤ 1.05)	$\leq 0.7\%$

2. MATH ASSUMPTIONS:

$$P_{RF} = \frac{2V_{COMP}(V_1 - V_0) + V_0^2 - V_1^2}{(4R)(EFFECTIVE\ EFFICIENCY)}$$

Assume:

$$V_0^2 - V_1^2 = (V_1 - V_0)^2 - (V_1 + V_0)^2 = -V_1^2 + 2V_1 - V_0^2$$

Want:

$$V_0^2 - V_1^2$$

Therefore error:

$$= (V_1^2 + 2V_1V_0 - V_0^2) - (V_0^2 - V_1^2)$$

$$= -2V_0^2 + 2V_1V_0 = 2V_0(V_1 - V_0)$$

If:

$$2V_0(V_1 - V_0) \ll 2V_{COMP}(V_1 - V_0)$$

That is:

if $V_0 \ll V_{COMP}$, then the error is negligible.

For example:

If $V_{COMP} \sim 4$ volts and $V_0 < 400 \mu\text{V}$, then the error is $< 0.01\%$.
(typically V_0 can be set to $< 50 \mu\text{V}$).

3. Derivation of the formula for $V_1 - V_0$:

$$P_{RF} = \frac{2V_{COMP}(V_1 - V_0) + V_0^2 - V_1^2}{(4R)(\text{EFFECTIVE EFFICIENCY})}$$

$$\text{Desired } P_{RF} = 1 \text{ mW} = 10^{-3} \text{ W}$$

Therefore:

$$10^{-3} = \frac{2V_{COMP}(V_1 - V_0) + V_0^2 - V_1^2}{(4R)(\text{EFFECTIVE EFFICIENCY})}$$

Let

$$(4R)(\text{EFFECTIVE EFFICIENCY})(10^{-3}) = K$$

Substitute $-(V_1 - V_0)^2$ for $V_0^2 - V_1^2$

(see Math Assumptions under Accuracy)

Then

$$0 = (V_1 - V_0)^2 - 2V_{COMP}(V_1 - V_0) + K$$

or

$$V_1 - V_0 = V_{COMP} - \sqrt{(V_{COMP})^2 - K}$$

