

**Agilent 16200B External DC Bias Adapter**

# **Operation and Service Manual**

**First Edition**



**Agilent Technologies**

**Agilent Part No. 16200-90001**

**October 2000**

Printed in Japan

---

## Notices

The information contained in this document is subject to change without notice.

This document contains proprietary information that is protected by copyright. All rights are reserved. No part of this document may be photocopied, reproduced, or translated to another language without the prior written consent of the Agilent Technologies.

Agilent Technologies Japan, Ltd.

Component Test PGU-Kobe

1-3-2, Murotani, Nishi-Ku, Kobe-shi, Hyogo, 651-2241 Japan

Copyright © Agilent Technologies Japan, Ltd. 2000

---

## Manual Printing History

The manual's printing date and part number indicate its current edition. The printing date changes when a new edition is printed. (Minor corrections and updates that are incorporated at reprint do not cause the date to change.) The manual part number changes when extensive technical changes are incorporated.

October 2000      First Edition (part number: 16200-90001)

---

## Safety Summary

The following general safety precautions must be observed during all phases of operation, service, and repair of this instrument. Failure to comply with these precautions or with specific WARNINGS elsewhere in this manual may impair the protection provided by the equipment. In addition it violates safety standards of design, manufacture, and intended use of the instrument.

Agilent Technologies assumes no liability for the customer's failure to comply with these requirements.

- **Ground The Instrument**

To avoid electric shock hazard, the instrument chassis and cabinet must be connected to a safety earth ground by the supplied power cable with earth blade.

- **DO NOT Operate In An Explosive Atmosphere**

Do not operate the instrument in the presence of flammable gasses or fumes. Operation of any electrical instrument in such an environment constitutes a definite safety hazard.

- **Keep Away From Live Circuits**

Operating personnel must not remove instrument covers. Component replacement and internal adjustments must be made by qualified maintenance personnel. Do not replace

components with the power cable connected. Under certain conditions, dangerous voltages may exist even with the power cable removed. To avoid injuries, always disconnect power and discharge circuits before touching them.

- **DO NOT Service Or Adjust Alone**

Do not attempt internal service or adjustment unless another person, capable of rendering first aid and resuscitation, is present.

- **DO NOT Substitute Parts Or Modify Instrument**

Because of the danger of introducing additional hazards, do not install substitute parts or perform unauthorized modifications to the instrument. Return the instrument to a Agilent Technologies Sales and Service Office for service and repair to ensure that safety features are maintained.

- **Dangerous Procedure Warnings**

Warnings, such as the example below, precede potentially dangerous procedures throughout this manual. Instructions contained in the warnings must be followed.

---

**WARNING**

---

**Dangerous voltages, capable of causing death, are presenting this instrument. Use extreme caution when handling, testing, and adjusting this instrument.**

---

## Safety Symbol

General definitions of safety symbols used on the instrument or in manuals are listed below.



Instruction Manual symbol: the product is marked with this symbol when it is necessary for the user to refer to the instrument manual.



Alternating current.



Direct current.



On (Supply).



Off (Supply).



In position of push-button switch.



Out position of push-button switch.



Frame (or chassis) terminal. A connection to the frame (chassis) of the equipment which normally include all exposed metal structure.

---

**WARNING**

---

**This warning sign denotes a hazard. It calls attention to a procedure, practice, condition or the like, which, if not correctly performed or adhered to, could result in injury or death to personnel.**

---

**CAUTION**

---

This Caution sign denotes a hazard. It calls attention to a procedure, practice, condition or the like, which, if not correctly performed or adhered to, could result in damage to or

---

destruction of part or all of the product.

---

**NOTE**

Note denotes important information. It calls attention to a procedure, practice, condition or the like, which is essential to highlight.

---

---

## Certification

Agilent Technologies certifies that this product met its published specifications at the time of shipment from the factory. Agilent Technologies further certifies that its calibration measurements are traceable to the United States National Institute of Standards and Technology, to the extent allowed by the Institution's calibration facility, or to the calibration facilities of other International Standards Organization members.

---

## Warranty

This Agilent Technologies instrument product is warranted against defects in material and workmanship for a period corresponding to the individual warranty periods of its component products. Instruments are warranted for a period of one year. Fixtures and adapters are warranted for a period of 90 days. During the warranty period, Agilent Technologies Company will, at its option, either repair or replace products that prove to be defective.

For warranty service or repair, this product must be returned to a service facility designated by Agilent Technologies. Buyer shall prepay shipping charges to Agilent Technologies and Agilent Technologies shall pay shipping charges to return the product to Buyer. However, Buyer shall pay all shipping charges, duties, and taxes for products returned to Agilent Technologies from another country.

Agilent Technologies warrants that its software and firmware designated by Agilent Technologies for use with an instrument will execute its programming instruction when property installed on that instrument. Agilent Technologies does not warrant that the operation of the instrument, or software, or firmware will be uninterrupted or error free.

---

## Limitation of Warranty

The foregoing warranty shall not apply to defects resulting from improper or inadequate maintenance by Buyer, Buyer-supplied software or interfacing, unauthorized modification or misuse, operation outside the environmental specifications for the product, or improper site preparation or maintenance.

---

**IMPORTANT**

No other warranty is expressed or implied. Agilent Technologies specifically disclaims the

---

---

implied warranties of merchantability and fitness for a particular purpose.

---

## Exclusive Remedies

The remedies provided herein are buyer's sole and exclusive remedies. Agilent Technologies shall not be liable for any direct, indirect, special, incidental, or consequential damages, whether based on contract, tort, or any other legal theory.

---

## Assistance

Product maintenance agreements and other customer assistance agreements are available for Agilent Technologies products.

For any assistance, contact your nearest Agilent Technologies Sales and Service Office. Addresses are provided at the back of this manual.

---

## Typeface Conventions

<b>Bold</b>	Boldface type is used when a term is defined. For example: <b>icons</b> are symbols.
<i>Italic</i>	Italic type is used for emphasis and for titles of manuals and other publications.
<b>[Hardkey]</b>	Indicates a hardkey labeled "Hardkey."
<b>Softkey</b>	Indicates a softkey labeled "Softkey."
<b>[Hardkey] - Softkey1 - Softkey2</b>	Indicates keystrokes <b>[Hardkey] - Softkey1 - Softkey2</b> .



<b>1. General Information</b>	
Introduction . . . . .	10
Using the 16200B . . . . .	10
Product Description . . . . .	10
Accessories Supplied . . . . .	10
Options Available . . . . .	11
Operating and Safety Precautions . . . . .	11
Operating . . . . .	11
Service . . . . .	11
Specifications . . . . .	12
<b>2. Preparation for Use</b>	
Introduction . . . . .	14
Initial Inspection . . . . .	14
Environmental Considerations . . . . .	16
Operating and Storage . . . . .	16
Instruction for Cleaning . . . . .	16
Fuse . . . . .	16
Connecting the Adapter for Use . . . . .	17
Repacking the Adapter . . . . .	18
<b>3. Operation</b>	
Using the 16200B with the 4291B . . . . .	20
Calibration . . . . .	20
Connecting the 16200B . . . . .	20
LOAD, SHORT and OPEN Compensation . . . . .	20
Compensation Procedure . . . . .	20
Using the 16200B with the other instruments . . . . .	22
Connecting the 16200B . . . . .	22
Calibration . . . . .	22
Connecting the Test Fixture to the 16200B . . . . .	22
Fixture Compensation . . . . .	22
Evaluating the DUT . . . . .	23
DC Bias . . . . .	23
You Can NOT Use the Internal DC BIAS Source of Your Instrument . . . . .	23
Requirement for External Current Source . . . . .	23
Current Limiting Resistor . . . . .	23
Additional Error . . . . .	23
<b>4. Service</b>	
Replaceable Parts . . . . .	26
Schematic Diagram . . . . .	27





---

**1** **General Information**

## Introduction

The purpose of this manual is to enable you to use your 16200B External DC Bias Adapter efficiently and confidently. This manual contains both general and specific information. To use the 16200B to perform a specific function (without having to read the entire manual), follow the directions in “Using the 16200B”.

---

## Using the 16200B

The 16200B has been designed to operate with the 4287A, 4291B, 4294A, 4395A, 4396B.

- To install the 16200B, refer to Chapter2.
  - To operate the 16200B, refer to Chapter3.
  - To order replaceable parts for the 16200B, refer to Chapter4.
- 

## Product Description

The 16200B has been designed to operate with the 4287A, 4291B, 4294A, 4395A, 4396B.

By connecting an external dc current source to the 16200B, the 16200B can supply a bias current across components of up to  $\pm 5$  A dc through a 7 mm one port type test fixture.

---

## Accessories Supplied

The following accessories are supplied with the 16200B:

**Table 1-1**                      **Furnished Accessories**

Description	Part Number	Quantity
Operation and Service Manual	16200-90001	1

## Options Available

The option 001 is supplied for the 16200B:

**Table 1-2 Option 001**

Description	Part Number	Quantity
Shorting Device (1mm × 0.5mm)	16191-29005	1
Shorting Device (1.6mm × 0.8mm)	16191-29006	1
Shorting Device (2mm × 1.25mm)	16191-29007	1
Shorting Device (3.2mm × 1.6mm)	16191-29008	1
LOAD Device (1mm × 0.5mm)	5182-0433	5
LOAD Device (1.6mm × 0.8mm)	5182-0434	5
LOAD Device (2.0mm × 1.25mm)	5182-0435	5
LOAD Device (3.2mm × 1.6mm)	5182-0436	5

## Operating and Safety Precautions

### Operating

You need observe only normal precautions when handling and operating the 16200B. Do not exceed the operating input power, voltage, and current level and signal type appropriate for the measurement instrument being used; refer to your instrument's operation manual.

### CAUTION

Electrostatic discharge (ESD) can damage the highly sensitive microcircuits in the 16200B External DC Bias Adapter. ESD damage is most likely to occur as the 16200B is being connected or disconnected. Protect the 16200B from ESD damage by wearing a grounding strap that provides a low resistance path to ground. Alternatively, ground yourself to discharge any static charge build-up by touching the outer shell of any grounded instrument chassis before touching the test port connectors.

Never touch a test port connector's center contacts.

Use a work station equipped with an anti-static work surface.

### Service

The voltage levels in this adapter do not warrant more than normal caution for operator safety. Nevertheless, service should be performed only by qualified personnel.

## Specifications

This section lists the complete 16200B specifications. These specifications are the performance standards and limits against which the 16200B is tested. When shipped from the factory, the 16200B meets the following specifications:

External DC Bias	Up to $\pm 5\text{A}$ , $\pm 40\text{ V}$ can be applied to the DC BIAS INPUT BNC connector.
Frequency Range	1 MHz to 1 GHz
Applicable Instrument	4287A, 4291B, 4294A, 4395A, 4396B
Applicable Fixture	16191A, 16192A, 16193A, 16194A, 16092A, 16093A/B, 16196A/B/C
Input Resistance	$1\text{ k}\Omega \pm 10\%$
Operating Temperature	0 to $55^\circ\text{C}$
Non-operating Temperature	$-40$ to $70^\circ\text{C}$
Operating Humidity	$\leq 95\%$ RH (@ $40^\circ\text{C}$ )
Non-operating Humidity	$\leq 95\%$ RH (@ $65^\circ\text{C}$ )
Dimensions	170 mm (W) $\times$ 70 mm (H) $\times$ 130 mm (D)
Weight	900 g

---

## **2** Preparation for Use

## **Introduction**

This chapter explains how to install the 16200B External DC Bias Adapter. The topics covered include initial inspection, ambient environmental considerations, connecting the adapter for use, and repacking the adapter.

---

## **Initial Inspection**

The adapter has been carefully inspected electrically and mechanically before being shipped from the factory. It should be in perfect physical condition, no scratches, dents or the like, and it should be in perfect electrical condition. Verify the adapter's physical condition by carefully performing an incoming inspection to check the adapter for signs of physical damage and missing contents. If any discrepancy is found, notify the carrier and Agilent Technologies promptly. Your Agilent Technologies sales office will arrange for repair and replacement without waiting for the claim to be settled.

1. Inspect the shipping container for damage, and keep the shipping materials until the inspection is satisfactorily completed.
2. Verify that the shipping container contains everything listed in Table 2-1.
3. Inspect the exterior of the 16200B for any signs of damage.

**Figure 2-1**      **Product Overview**



**Table 2-1**      **Contents**

Description	Agilent Part Number	Quantity
External DC BIAS Adapter	-	1
Operation and Service Manual	16200-90001	1

**Table 2-2**      **Option 001**

Description	Agilent Part Number	Quantity
Shorting Device (1mm × 0.5mm)	16191-29005	1
Shorting Device (1.6mm × 0.8mm)	16191-29006	1
Shorting Device (2mm × 1.25mm)	16191-29007	1
Shorting Device (3.2mm × 1.6mm)	16191-29008	1
LOAD Device (1mm × 0.5mm)	5182-0433	5
LOAD Device (1.6mm × 0.8mm)	5182-0434	5
LOAD Device (2.0mm × 1.25mm)	5182-0435	5
LOAD Device (3.2mm × 1.6mm)	5182-0436	5

## **Environmental Considerations**

### **Operating and Storage**

The 16200B should be operated within an ambient temperature range of 0°C to 55°C and relative humidity up to 95% RH at 40°C (non-condensing).

The 16200B may be stored within a temperature range of -40°C to +70°C, and at a relative humidity of up to 90% RH at +65°C (non-condensing).

---

## **Instruction for Cleaning**

For cleaning, wipe with soft cloth that is soaked with water and wrung tightly without undue pressure.

---

### **Fuse**

Use the following fuse:

Agilent Part Number: 2110-0056  
(UL/CSA type, Normal-Blow 6A 250V)

If you need this fuse, contact your nearest Agilent Technologies Sales and Service Office.



## Connecting the Adapter for Use

**CAUTION** Make sure that the current source is turned off before you start making connections.

**Figure 2-2** Connecting the Adapter

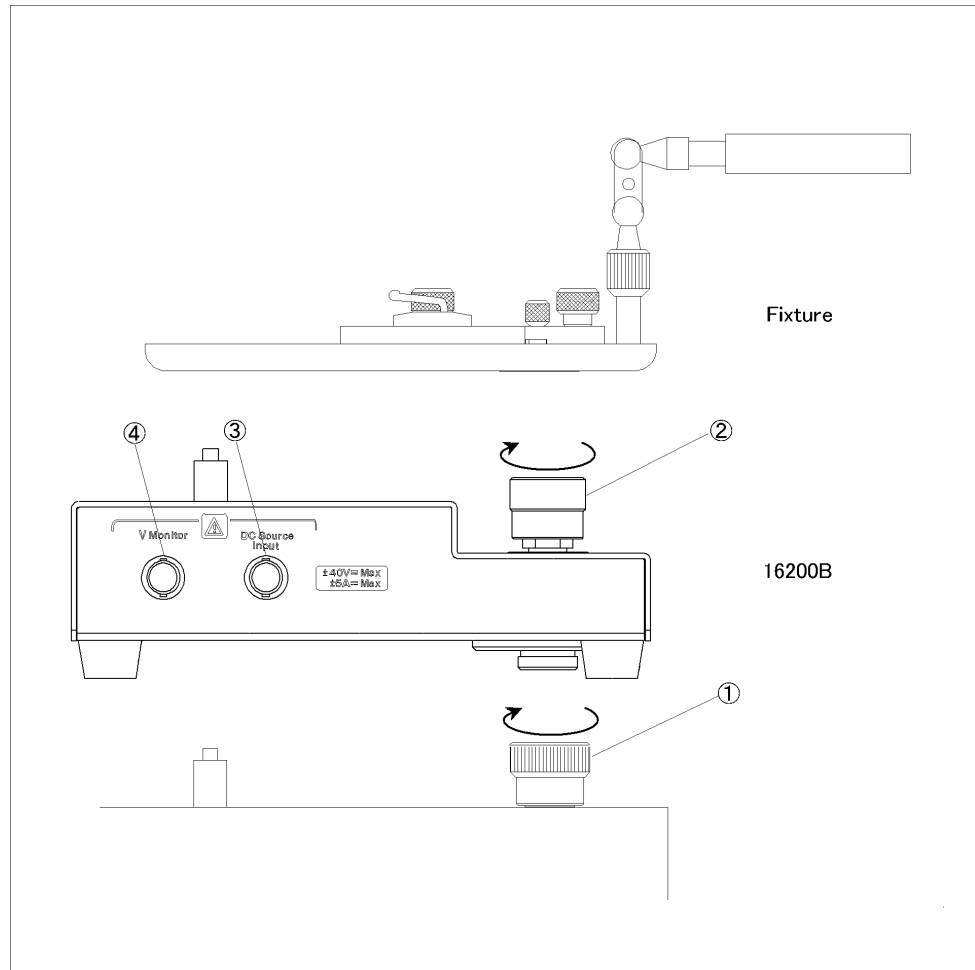

1. This is connected to the 7 mm Connector on the test station.
2. This is connected to a 7 mm Connector on a test fixture.
3. *DC Source Input*. This terminal is connected to an external current source in order to apply dc bias current to the DUT.
4. *V Monitor*. This terminal is connected to a Volt Meter to monitor the dc bias level.

## **Repacking the Adapter**

If it is necessary to ship the adapter(s) to an Agilent Technologies service center, each adapter should be repacked using the original factory packaging materials.

Alternatively, comparable packaging materials may be used. Wrap the adapter in heavy paper and pack in anti-static plastic packing material. Use sufficient shock absorbing material on all sides of the 16200B to provide a thick, firm cushion and to prevent movement. Seal the shipping container securely and mark it *FRAGILE*.

---

## **3** **Operation**

This chapter describes how to use the 16200B with the instruments.

## Using the 16200B with the 4291B

This section describes how to use the 16200B with the 4291B.

### Calibration

Calibration must be performed at the 7 mm connector on the test head and before the 16200B is attached to the test station. Refer to the calibration procedure described in the 4291B RF Impedance/Material Analyzer User's Guide.

### Connecting the 16200B

After the calibration of the test station has been completed, connect the connector on the underside of the 16200B to the 7 mm connector on the test station and connect the connector on the underside of the test fixture to the 7 mm connector on the upper side of the 16200B.

### LOAD, SHORT and OPEN Compensation

The 16200B and the test fixture have inherent stray capacitance, residual inductance, and residual resistance which, if not properly compensated for before making measurements, will degrade measurement accuracy. To correct for these residuals and thus minimize measurement error, the measuring instrument's LOAD, SHORT and OPEN compensation capability must be used.

#### Configuration for Compensation Key Sequence

1. Press **[CAL]**
2. Press **COMPEN KIT, MODIFY, DEFINE STANDARD, LOAD: RESIST(R)**
3. Press **[5] [1] [×1]**
4. Press **STD DONE (DEFINE), KIT DONE (MODIFIED)**
5. Set the oscillator level, frequency and other parameters to the desired levels.

### Compensation Procedure

#### LOAD Fixture Compensation

LOAD Compensation corrects the phase-shift induced error, making the Electrical Length Compensation unnecessary. From the LOAD devices supplied with the adapter, select a LOAD with an impedance value that is accurately known and stable and that is nearest in size to the DUT. Mount the selected LOAD device on the test fixture. Refer to "Performing SHORT Compensation" in "Fixture Compensation" in 4291B RF Impedance/Material Analyzer User's Guide for a detailed description of how to mount devices on the test fixture.

After mounting the LOAD device in the test fixture, perform the LOAD Compensation on the 4291B. When LOAD Compensation is finished, the **LOAD** softkey label is underlined on the display screen. Remove the LOAD device from the test fixture.

### **SHORT Fixture Compensation**

From the shorting devices supplied with the test fixture or the adapter, select the shorting device that is nearest in size to the DUT, and mount it on the test fixture.

After mounting the shorting device in the test fixture, perform SHORT Compensation. When SHORT Compensation is finished, the **SHORT** softkey label is underlined on the display screen. Remove the shorting device from the test fixture.

### **OPEN Fixture Compensation**

First mount the DUT in the test fixture and then remove it to create an OPEN condition with an air gap that is the same size as the DUT. After removing the DUT from the test fixture, perform OPEN Compensation. When OPEN Compensation is finished, the **OPEN** softkey label is underlined on the display screen.

### **Completing the Compensation Procedure**

When LOAD, SHORT and OPEN Compensation have all been successfully completed, press the following front panel key sequence:

1. Press **DONE COMPEN**

---

**CAUTION**

---

Do NOT turn on the external DC voltage source while compensation is in progress.

## Using the 16200B with the other instruments

This section describes how to use the 16200B with the 4287A, 4294A, 4395A or 4396B.

### Connecting the 16200B

To connect the DC Bias Adapter to the instrument, an accessory is required. Table 3-1 shows the required accessories. For a more detail procedure to connect the 16200B to the accessory, refer to their manual.

**Table 3-1 Required Accessory to connect the 16200B**

<b>Instrument</b>	<b>Required Accessory</b>
4294A	42942A Terminal Adapter
4287A	Test Fixture Stand with Test Head (furnished with the 4287A)
4395A	43961A Impedance Test Kit
4396B	43961A Impedance Test Kit

### Calibration

Calibration must be performed on the DC Bias Adapter before the Test Fixture is attached. Execute the calibration in accordance with the Operation Manual for the measuring instrument you are using.

### Connecting the Test Fixture to the 16200B

After the calibration of the DC Bias Adapter has been completed, connect the connector on the underside of the test fixture to the 7 mm connector on the upper side of the 16200B. For a more detailed procedure, refer to the fixture's manual.

### Fixture Compensation

The test fixture has inherent stray capacitance, residual inductance, and phase-shift induced error which, if not properly compensated for before making measurements, will degrade measurement accuracy. To correct for these residuals and thus minimize measurement error, the measuring instrument's OPEN and SHORT compensation capability and electrical compensation must be used. Execute the fixture compensation and set the electrical length in accordance with the Operation Manual for the measuring instrument you are using.

---

## Evaluating the DUT

Insert the DUT in the test fixture and make the desired measurements.

Next, attach the dc power supply cable to the DC source input, turn on an external dc power supply and adjust the voltage on the power supply to the desired value. The impedance, capacitance and other values may then be read on the display screen on the measurement instrument.

---

**CAUTION** Do NOT short the high and low terminals when the voltage source is turned *ON*.

---

**CAUTION** When measuring an electrolytic capacitor and a positive bias voltage is used, the positive terminal of an electrolytic capacitor must be connected to the test fixture's high terminal. When using a negative bias voltage, connect the negative terminal of an electrolytic capacitor to the test fixture's high terminal.

---

**NOTE** When measuring high value capacitors, allow sufficient time for the capacitor to charge to the applied voltage.

---

---

## DC Bias

### You Can NOT Use the Internal DC BIAS Source of Your Instrument

The 16200B contains a capacitor, series connected between the 7 mm terminal and the component under test. Its function is to block the applied dc voltage from flowing back into the measuring instrument. Also, because of its location, this capacitor makes it impossible to bias samples from the measuring instrument's internal bias source. Thus, the 16200B can not be used for applications in which the instrument's internal bias source is used.

### Requirement for External Current Source

The external dc current source used for biasing samples connected to the 16200B must be capable of delivering 5A.

### Current Limiting Resistor

When external dc voltage source is used, a 2 k $\Omega$ (2W) current limiting resistor should be connected in series with the dc voltage output.

### Additional Error

The additional error for impedance measurement may be calculated using the following equation:

Where  $1 \text{ MHz} \leq f \leq 1 \text{ GHz}$  and dc bias is 0 A:

Operation  
**DC Bias**

$$\left(1 + \frac{f}{500}\right)^3 \left(\frac{Z_x}{50} + \frac{5}{Z_x}\right) \%$$

Where the dc bias current applied:

$$\left(\frac{1}{4} + \frac{Z_x}{200}\right) I \%$$

Where f is measurement frequency in MHz,  
Zx is impedance of DUT in  $\Omega$ ,  
I is current in A.



---

## **4** **Service**

This chapter gives service information for the 16200B. The Replaceable Parts List and the Schematic Diagram are included.

## Replaceable Parts

Figure 4-1 and Table 4-1 identify the replaceable mechanical parts. The parts listed can be ordered from your nearest Agilent Technologies office. Ordering information should include the Agilent part number and the quantity required.

**Figure 4-1** Replaceable Parts Identifiers

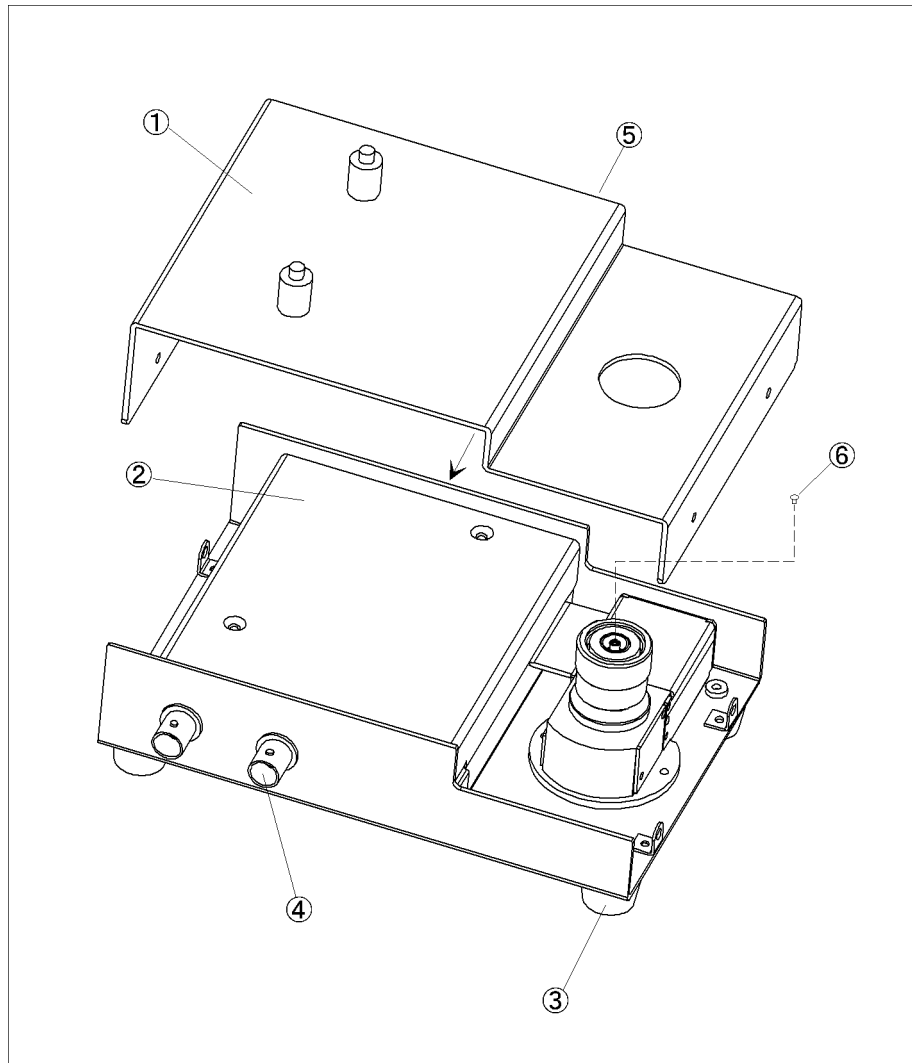

**Table 4-1 Replaceable Mechanical Parts**

Reference Designator	Agilent Part Number	Qty.	Description
1	16200-00621	1	Top Cover
2	16200-65002	1	Body
3	0403-0786	4	Bumper Foot
4	1250-0083	2	Connector BNC (for “Ext DC Bias“ and monitoring for DC Bias level)
5	2110-0565	1	Fuse Cover
	2110-0056	1	Fuse (6A)
6	1250-0907	1	CONTACT CENTER

## Schematic Diagram

Figure 4-2 shows the schematic diagram of the 16200B.

**Figure 4-2**

**16200B Schematic Diagram**

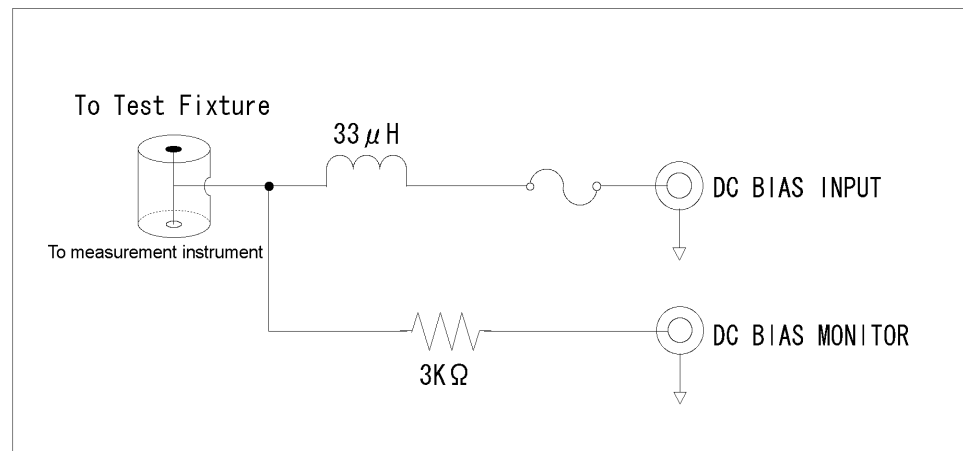

AL004002

Service  
**Schematic Diagram**