

Agilent 16034E Test Fixture

Operation and Service Manual

Third Edition

Agilent PN 16034-90041

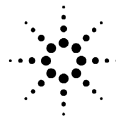

Agilent Technologies

Innovating the HP Way

December 1999

Printed in: Japan

Notices

The information contained in this document is subject to change without notice.

This document contains proprietary information that is protected by copyright. All rights are reserved. No part of this document may be photocopied, reproduced, or translated to another language without the prior written consent of the Agilent Technologies.

Agilent Technologies Japan, LTD.

Component Test PGU-Kobe

1-3-2, Murotani, Nishi-Ku, Kobe-shi, Hyogo, 651-2241 Japan

Copyright © 1992, 1998, 1999 Agilent Technologies Japan, Ltd.

Manual Printing History

The manual's printing date and part number indicate its current edition. The printing date changes when a new edition is printed. (Minor corrections and updates that are incorporated at reprint do not cause the date to change.) The manual part number changes when extensive technical changes are incorporated.

July 1992 First Edition (part number: 16034-90040)

August 1998 Second Edition (part number: 16034-90041)

December 1999 Third Edition (part number: 16034-90041)

Safety Summary

The following general safety precautions must be observed during all phases of operation, service, and repair of this instrument. Failure to comply with these precautions or with specific WARNINGS elsewhere in this manual may impair the protection provided by the equipment. In addition it violates safety standards of design, manufacture, and intended use of the instrument.

The Agilent Technologies assumes no liability for the customer's failure to comply with these requirements.

- Ground The Instrument

To avoid electric shock hazard, the instrument chassis and cabinet must be connected to a safety earth ground by the supplied power cable with earth blade.

- **DO NOT Operate In An Explosive Atmosphere**

Do not operate the instrument in the presence of flammable gasses or fumes. Operation of any electrical instrument in such an environment constitutes a definite safety hazard.

- **Keep Away From Live Circuits**

Operating personnel must not remove instrument covers. Component replacement and internal adjustments must be made by qualified maintenance personnel. Do not replace components with the power cable connected. Under certain conditions, dangerous voltages may exist even with the power cable removed. To avoid injuries, always disconnect power and discharge circuits before touching them.

- **DO NOT Service Or Adjust Alone**

Do not attempt internal service or adjustment unless another person, capable of rendering first aid and resuscitation, is present.

- **DO NOT Substitute Parts Or Modify Instrument**

Because of the danger of introducing additional hazards, do not install substitute parts or perform unauthorized modifications to the instrument. Return the instrument to a Agilent Technologies Sales and Service Office for service and repair to ensure that safety features are maintained.

- **Dangerous Procedure Warnings**

Warnings, such as the example below, precede potentially dangerous procedures throughout this manual. Instructions contained in the warnings must be followed.

WARNING

Dangerous voltages, capable of causing death, are presenting this instrument. Use extreme caution when handling, testing, and adjusting this instrument.

Certification

Agilent Technologies certifies that this product met its published specifications at the time of shipment from the factory. Agilent Technologies further certifies that its calibration measurements are traceable to the United States National Institute of Standards and Technology, to the extent allowed by the Institution's calibration facility, or to the calibration facilities of other International Standards Organization members.

Warranty

This Agilent Technologies instrument product is warranted against defects in material and workmanship for a period corresponding to the individual warranty periods of its component products. Instruments are warranted for a period of one year. During the warranty period, Agilent Technologies will, at its option, either repair or replace products that prove to be defective.

For warranty service or repair, this product must be returned to a service facility designated by Agilent Technologies. Buyer shall prepay shipping charges to Agilent Technologies and Agilent Technologies shall pay shipping charges to return the product to Buyer. However, Buyer shall pay all shipping charges, duties, and taxes for products returned to Agilent Technologies from another country.

Agilent Technologies warrants that its software and firmware designated by Agilent Technologies for use with an instrument will execute its programming instruction when properly installed on that instrument. Agilent Technologies does not warrant that the operation of the instrument, or software, or firmware will be uninterrupted or error free.

Limitation Of Warranty

The foregoing warranty shall not apply to defects resulting from improper or inadequate maintenance by Buyer, Buyer-supplied software or interfacing, unauthorized modification or misuse, operation outside the environmental specifications for the product, or improper site preparation or maintenance.

IMPORTANT

No other warranty is expressed or implied. Agilent Technologies specifically disclaims the implied warranties of merchantability and fitness for a particular purpose.

Exclusive Remedies

The remedies provided herein are buyer's sole and exclusive remedies. Agilent Technologies shall not be liable for any direct, indirect, special, incidental, or consequential damages, whether based on contract, tort, or any other legal theory.

Assistance

Product maintenance agreements and other customer assistance agreements are available for Agilent Technologies products.

For any assistance, contact your nearest Agilent Technologies Sales and Service Office. Addresses are provided at the back of this manual.

Safety Symbol

General definitions of safety symbols used on the instrument or in manuals are listed below.



Instruction Manual symbol: the product is marked with this symbol when it is necessary for the user to refer to the instrument manual.

WARNING

This warning sign denotes a hazard. It calls attention to a procedure, practice, condition or the like, which, if not correctly performed or adhered to, could result in injury or death to personnel.

CAUTION

This Caution sign denotes a hazard. It calls attention to a procedure, practice, condition or the like, which, if not correctly performed or adhered to, could result in damage to or destruction of part or all of the product.

NOTE

Note denotes important information. It calls attention to a procedure, practice, condition or the like, which is essential to highlight.

Contents

1. Operation	
Product Description	10
Operation	11
Specifications	13
Typical Characteristics	14
2. Service	
Maintenance	16

1 **Operation**

This Operating note provides Operating and service information for the Agilent 16034E Test Fixture. Specifications are listed in Table 1-1.

Product Description

This test fixture is designed to facilitate easy and accurate measurements of chip type components and similar types not furnished with lead wires. Connection of sample components to the 16034E is done by simply pressing the loading lever to left, inserting sample components in the V-mount center section (between fixture jaws) and releasing lever. Components which may be measured with the 16034E are the rectangular paralleled chip, cylindrical chip, and other similar in shape and type to components shown in Table 1-1.

Figure 1-1

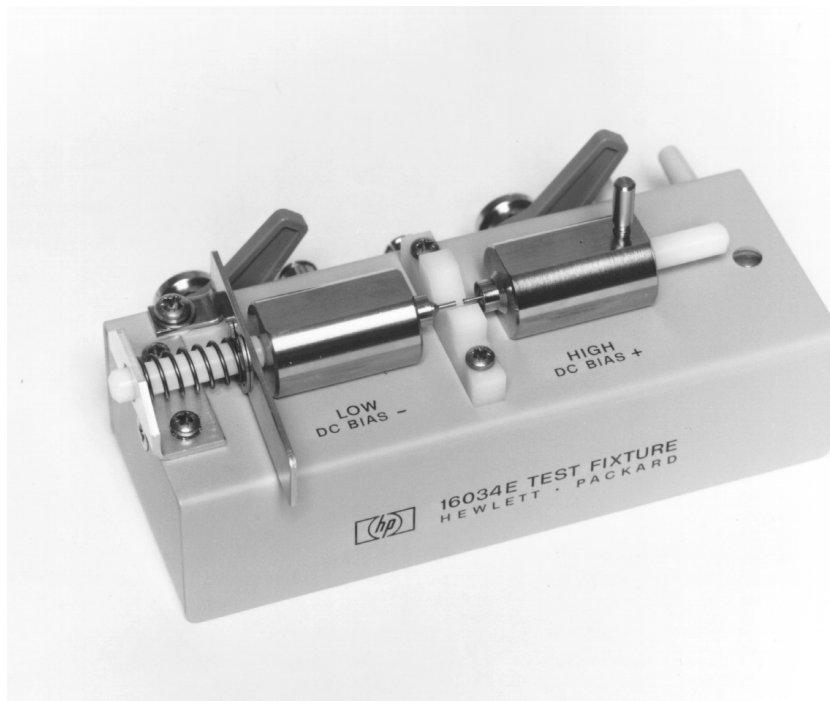

Operation

The set up and measurement procedure is as follows:

1. Set the cable length to 0m.
2. Connect the 16034E directly to the UNKNOWN terminals.
3. Loosen the knob A.

Figure 1-2

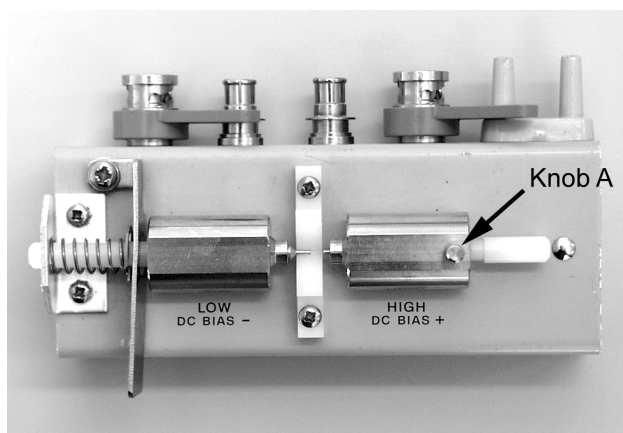

4. Adjust the contact pin position on the V-mount center section with the knob B to adapt your DUT size.

Figure 1-3

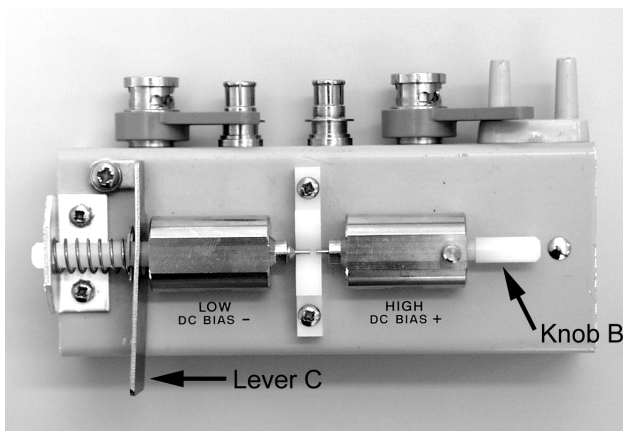

5. Tighten the knob A to fix the contact pin.
6. Make the right and the left contact pins contact.
7. Perform the short compensation described in the instrument's operation manual.
8. Pressing the loading lever C to left.
9. Hold the lever C so that the gap of contact is as same as the DUT's length.

Operation
Operation

10. Perform the open compensation described in the instrument's operation manual.
11. Inserting a sample components in the V-mount center section (between fixture jaws).
12. Releasing the lever C to fix the DUT.

Figure 1-4

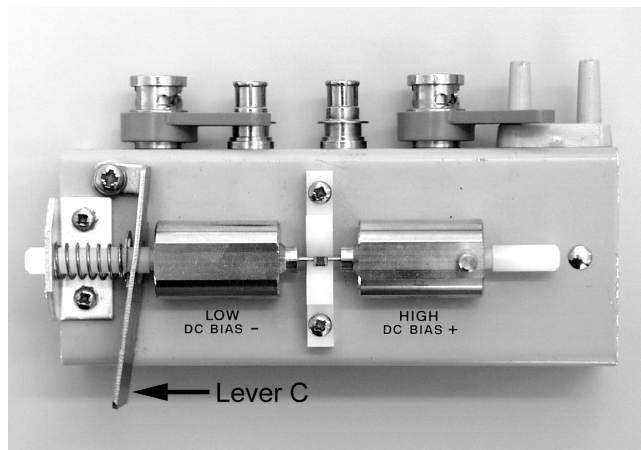

WARNING

DO NOT APPLY MORE THAN $\pm 40\text{V}$ OF DC BIAS VOLTAGE TO THE UNKNOWN TERMINALS. AN ELECTRICAL SHOCK HAZARD WILL EXIST DURING OPERATION WHEN THE DC BIAS VOLTAGE IS GREATER THAN $\pm 40\text{V}$ DC.

Specifications

Table 1-1 Specification of the 16034E.

Function:	For use with 4 terminal-pair LCR Meters and Impedance Analyzers.
Measurable components:	Chip type components (Not furnished with lead wires)
Dimension of measurable components:	<div style="text-align: center;"> <p>Rectangular parallel electrode chip components Cylindrical shaped chip components</p> <p>L: 0.1 ~ 8.0mm H: 0.5~10.0mm W: 0.5~10.0mm T: 0.5~ 3.0mm</p> </div>
Frequency:	≤ 40 MHz
Maximum Voltage:	± 40 V peak max.(AC + DC)
Dimensions of test fixture:	128 (W) \times 60 (H) \times 71 (D) mm
Weight:	270 g

Typical Characteristics

Table 1-2

Typical characteristics

Incremental Error at $f \geq 1$ MHz	
Parameter reading error (%)	Offset Value for D
$\pm 1.50 \times \left(\frac{f}{10}\right)^2$	

NOTE

f is the measurement frequency in MHz. The incremental errors calculated from the equations given in this table are additive when measurements are made above 1MHz. The incremental error is applicable after completion of the OPEN/SHORT compensation.

Figure 1-5

2 **Service**

Maintenance

An exploded view of the 16034E for parts identification is shown in Figure 2-1 and Figure 2-2. Do not disassemble any further than shown. Maintenance consists principally of cleaning contacts and replacing worn or damaged parts. Take special care when cleaning contacts.

To order parts, use the Agilent Technologies part numbers listed in Table 2-1. If a faulty part is located in an assembly that cannot be disassembled, order the next higher assembly or return the fixture to the nearest Agilent Technologies Sales/Service Office for repair or replacement.

Figure 2-1 Parts Identification

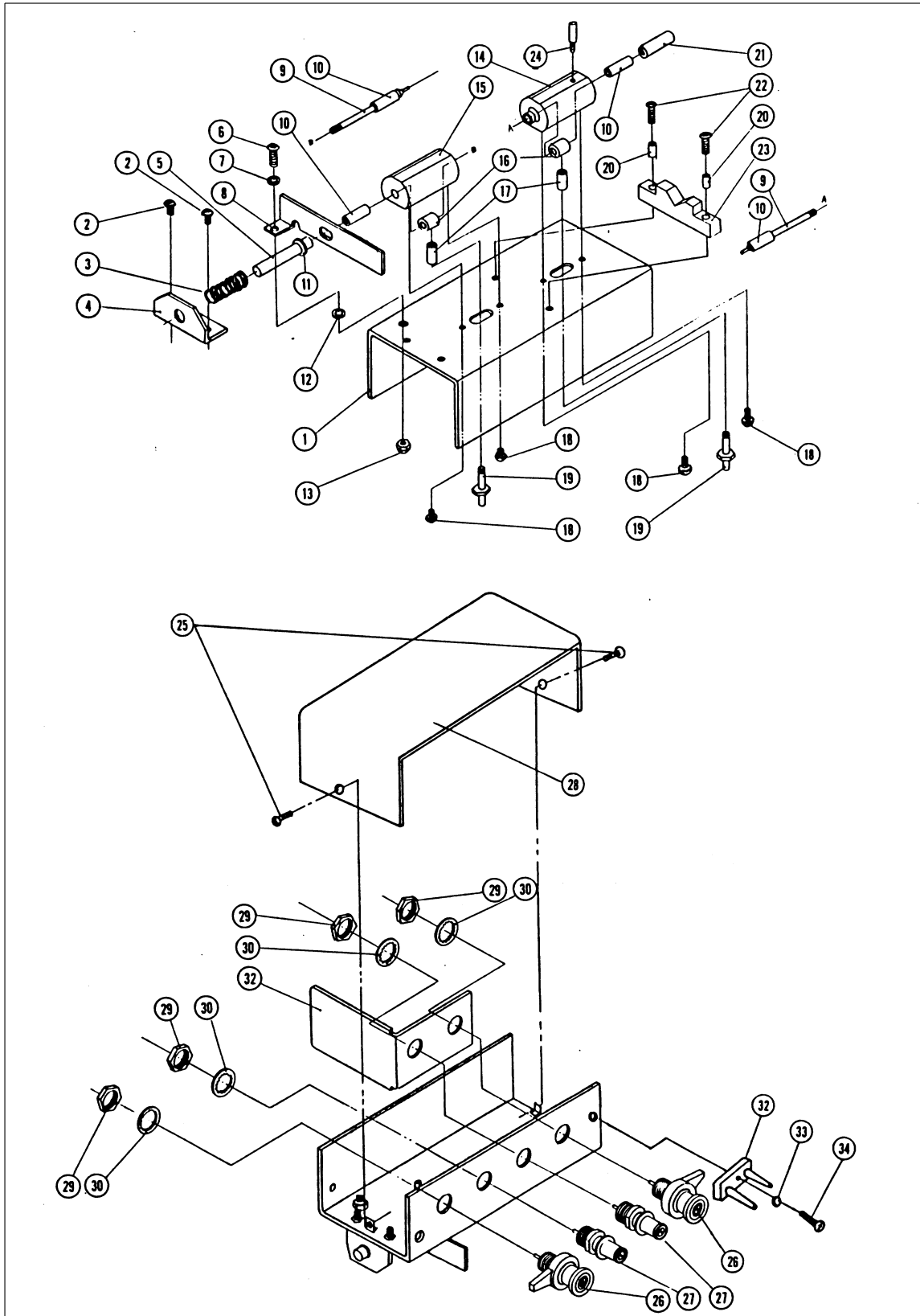

Figure 2-2 Parts Identification

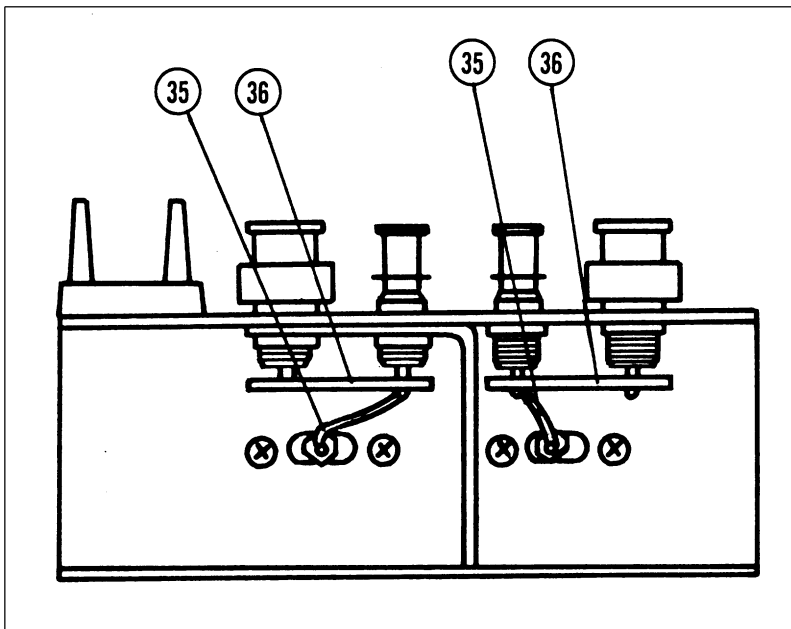

Table 2-1

Reference Designation	Agilent Part No.	Qty.	Description
1	16034-00221	1	TOP COVER
2	2200-0103	2	SCREW
3	1460-0323	1	SPRING
4	16034-01202	1	BRACKET
5	16034-25004	1	KNOB
6	2360-0201	1	SCREW
7	3050-0228	1	WASHER
8	16034-05001	1	LEVER
9	16034-23001	2	SHAFT
10	16034-25002	4	COLLAR
11	0510-0083	1	ERING
12	3050-1138	1	WASHER
13	2420-0006	1	NUT
14	16034-20002	1	BLOCK
15	16034-20001	1	BLOCK

Reference Designation	Agilent Part No.	Qty.	Description
16	16034-24001	2	COLLAR
17	16034-25001	2	COLLAR
18	2200-0101	4	SCREW
19	16034-20003	2	PLUG
20	0380-0044	2	COLLAR
21	16034-25003	1	KNOB
22	2200-0769	2	SCREW
23	16034-25005	1	BLOCK
24	16034-23013	1	SCREW
25	2360-0192	2	SCREW
26	16012-7122	2	BNC ASS'Y
27	1250-1798	2	BNC
28	16034-00222	1	BOTTOM COVER
29	2950-0043	4	NUT
30	2190-0016	4	WASHER
31	16034-00601	1	SHIELD PLATE
32	16047-40000	1	STOPPER
33	2190-0206	1	WASHER
34	2200-0105	1	SCREW
35	16034-68021	2	J.W.L
36	16047-00617	2	PLATE