

Keysight Technologies

Improving Throughput in Network Analyzer Applications

Application Note

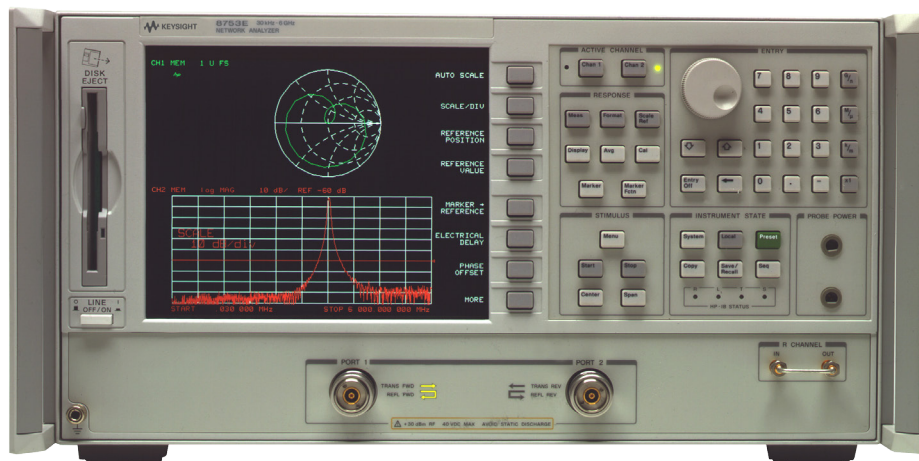

Table of Contents

2	Introduction
3	Throughput Considerations
5	Sweep Speed
12	Instrument State Recall Speed
13	Automation and Data Transfer Speed
15	Measurement Accuracy
18	Device Connection Time
20	Instrument Uptime
20	Product Quality
20	Conclusion
21	Checklist for Increasing Measurement Throughput
22	Appendix
23	Third-Party Companies.

Introduction

In today's competitive environment, prices for electronic components are continually decreasing. Reducing manufacturing cost by improving throughput, while maintaining product quality, is an important goal for many production test engineers and managers. The topic of improving throughput is very broad, and it can span methods from how to minimize testing and the number of specifications to using just-in-time (JIT) manufacturing with a Kanban inventory-control system. This note will not cover broad throughput issues such as whether distributed testing versus centralized testing is more efficient or cost effective. Instead, this application note will focus only on test processes that include network analyzers.

Even within the relatively focused topic of network analyzer applications, many factors need to be considered when deciding how to improve throughput. It isn't always as simple as analyzing instrument specifications and choosing a network analyzer with the best measurement speed per data point. It is also important to consider all the aspects of throughput that may be applicable for your situation. This application note explores a variety of throughput issues and how they might affect different applications. It suggests ways to improve network analyzer performance for better throughput in specific situations, and how to get an accurate picture of how an analyzer's performance might impact overall throughput.

This application note broadly covers network analyzer throughput and applies to many different models of the Keysight Technologies, Inc. network analyzers. Therefore, for specific details on how to use certain features with the Keysight 8753, 8711, or 8720 families of network analyzers, please refer to the operating and programming manuals for these products.

The level of information presented here assumes that the reader has some familiarity with network analyzers and their usage. If you need basic information, please refer to the references listed in the appendix.

Throughput Considerations

When considering throughput, it is important to examine the overall measurement process, which is likely to consist of a number of steps. For example, a production line might have a process where operators use network analyzers to perform manual tuning on filters. The process might include connecting a filter, recalling a test setup (or instrument state) on the analyzer, tuning, and watching for a desired result (indicated perhaps by markers that display values, or limit lines that display whether a device passes or fails). More tuning might be necessary, then the operator might move on to a different instrument state to tune another parameter, and so on. (See Figure 1.)

Another example is an automated final test that uses a part handler. Here the process might include the part handler placing a part in a test fixture, setting up an instrument state, taking data, transferring data to a PC, having a PC perform calculations or store data to a file, and then setting up an analyzer for the next test. The instrument-state setup might be done by recalling an instrument-state file that had previously been set up and stored, or the PC could issue commands to the analyzer to set up the desired conditions.

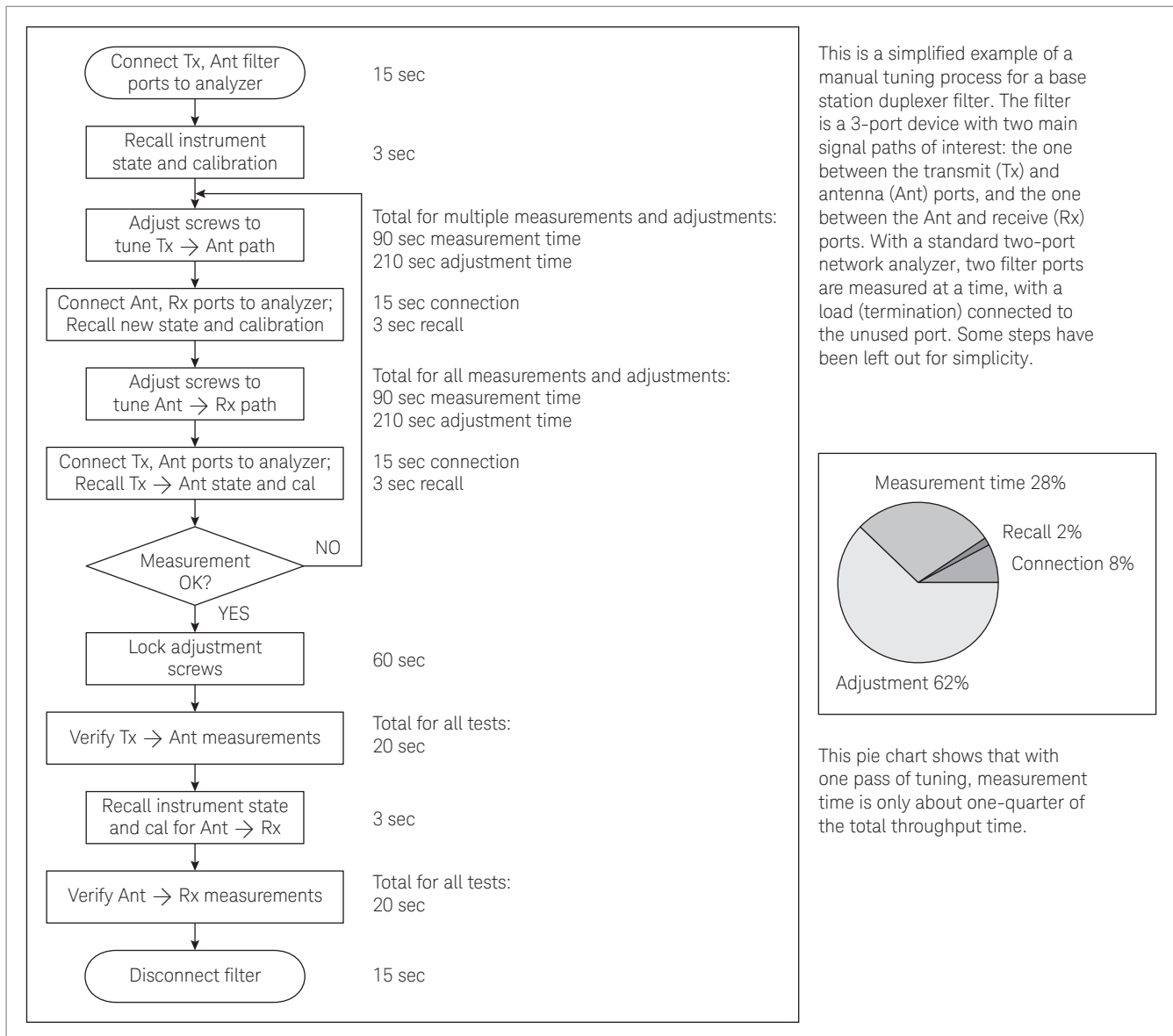

Figure 1. Example manual-tuning process for a base-station filter

These two examples demonstrate how throughput issues might be different in various applications. For manual tuning, faster sweep speed is important. However, once the user perceives a continuous update of data (approximately 30 updates per second), any faster update speed would not be noticeable or result in an increase in filter throughput. Conversely, faster sweep speed could be useful in automated testing where a computer is faster than an analyzer. Part-handler speed and data-transfer speed are not relevant to the manual tuning application, but the time needed to manually connect the test device is relevant. The time required to recall or set up an instrument state is important in both applications.

It is also important to consider the relative importance and value of improving each part of the process. Many people focus on the sweep time of a network analyzer when trying to improve throughput, but improving sweep time alone does not always provide the best throughput improvement. For example, in a multiport test application, if it takes the operator 1.5 minutes to connect a new device into place, while the analyzer takes 10 seconds to perform the test, then cutting the analyzer test time in half only reduces the total test time from 100 seconds to 95 seconds for a 5% improvement. However, reducing the device connection time to 1 minute will reduce the total test time to 70 seconds, which is a 30% improvement.

The complete test process might include additional items such as calibration time that are not part of testing every device, but they might need to be done occasionally and will affect the overall throughput. Calibration time can range from a few minutes for a simple one-port calibration to several hours for a series of two-port calibrations for testing a high dynamic-range multiport device.

For this application note, throughput considerations are divided into the following topics:

- Sweep speed
- Instrument state recall speed
- Automation and data transfer speed
- Measurement accuracy
- Device connection time
- Instrument uptime
- Product quality

Each topic will be described in greater detail and suggestions for improving throughput in each area will be provided

Sweep Speed

Sweep speed (also referred to as sweep time) can be a confusing term; not everyone means the same thing when referring to sweep speed. In general, sweep speed refers to the amount of time needed for the analyzer to take one sweep of the source and acquire data over the defined range. Many analyzers' technical specifications report a number in the form of time per data point, which one might assume would yield the sweep time when multiplied by the number of points in a trace. Many instruments also have a function that reports a value for hardware sweep time. However, users may never get this sweep time in their measurements, because in reality what they will get is the "cycle time." This cycle time includes sweep (hardware) set-up time, band-switch times (when the source or receiver crosses frequency bands), data-acquisition time, retrace time (for the source to move from the end of one sweep to the start of the next one), data-calculation and formatting time, and display update time (see Figure 2). Also, error-correction time might not be included, and if two-port calibration is used, the analyzer might need to take two sweeps instead of one for each display update (see the "Measurement Accuracy" section for more details on calibration). So, for the purpose of consistency in this application note, "sweep speed" refers to "cycle time" unless otherwise stated.

Also, it is important not to assume that an analyzer's sweep speed under actual test conditions will be the same as the time-per-point number published in the technical specifications. In most technical specifications, the value reported is a best-case number. Often it is measured at the instrument's widest IF bandwidth (which might have too much trace noise and too little dynamic range to be useful), with a single-band sweep to avoid band switch delays, and with the highest number of points (to spread out the effects of overhead items such as sweep set-up time and obtain the smallest time value per point). Actual sweep speed is closely tied to an instrument's set-up parameters, including the number of points and frequency range, and the degree of accuracy and amount of dynamic range required (which also impact the type of calibration necessary).

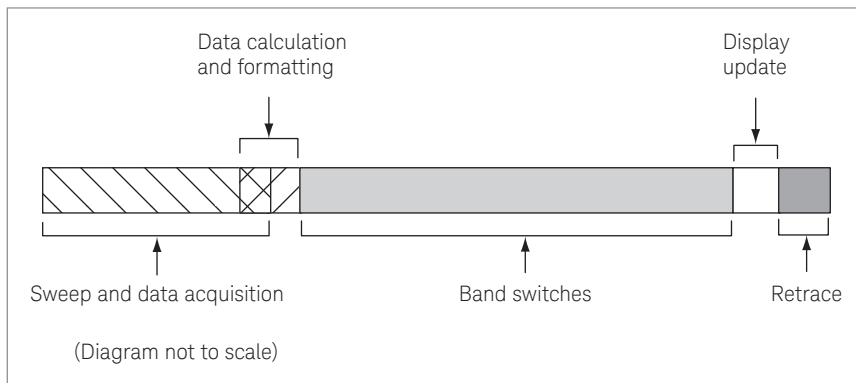

Figure 2. Components of cycle time

Here are some ideas to optimize sweep speed and cycle time.

IF Bandwidth: Use the widest IF bandwidth with acceptable dynamic range and trace noise.

Wider IF bandwidths result in faster measurements, but they also give you more trace noise (ripples in high-power-level measurements) and higher noise floor (less dynamic range). Typically, a ten-fold reduction in IF bandwidth will give you a 10 dB reduction in the noise floor. Use the widest IF bandwidth that will give you reasonable results, especially with regard to trace noise and dynamic range. Figure 3 shows an example of some typical relationships between IF bandwidth, trace noise, and sweep speed for the Keysight 8753E RF network analyzer.

Note that narrowing the IF bandwidth in some Keysight network analyzers such as those in the 8753 and 8720 families has the same effect as increasing point-by-point averaging in other analyzers such as the 8510. In the 8753 and 8720 families, the averaging feature performs a trace-by-trace average. Refer to the operating manuals for these analyzers for more details.

Test Set Changes: Consider special test set configurations for higher dynamic range.

If a lower noise floor is required only in the forward direction, you can configure the test set to bypass the usual coupler loss on port 2 for transmitted signals. The Keysight 8720D family provides this capability with Option 012, direct sampler access. As shown in Figure 4, you can connect the output of your device under test directly into the B sampler, instead of to port 2. This direct connection increases your dynamic range by about 20 dB, which is the amount of the coupling loss.

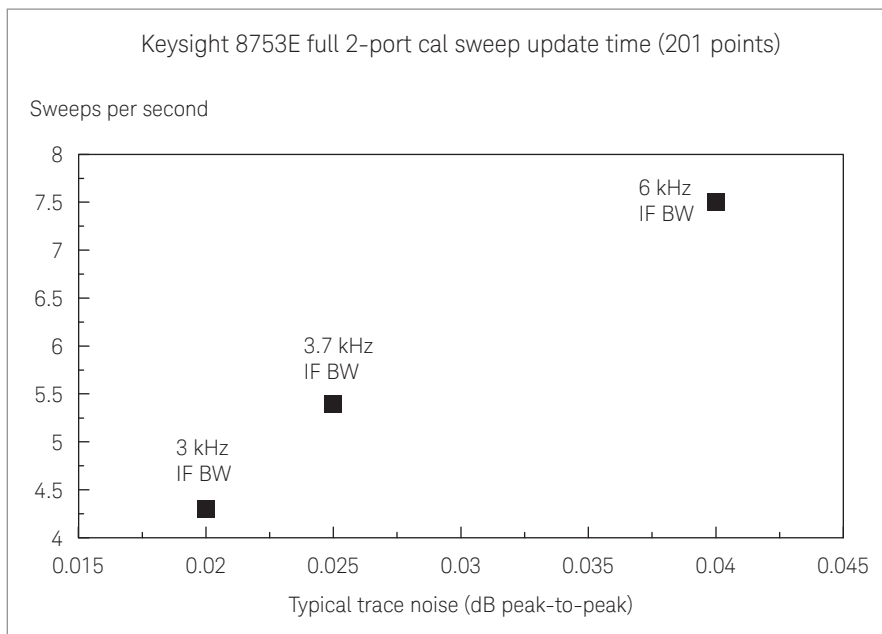

Figure 3. IF bandwidth vs. trace noise and sweep speed

For analyzers such as the 8753, you can get a special version of the test set with the coupler reversed on port 2 (see Figure 5). The reversed coupler will improve the sensitivity because the signal entering port 2 is routed to the sampler via the through arm of the coupler (with a few dB of loss) rather than the coupled arm, which has a loss equal to the coupling factor (typically 15 to 20 dB). The output power from port 2 will now be reduced by the coupling factor, so reverse direction measurements will have less dynamic range than normal, which is why this configuration is only recommended if high dynamic range is needed in one direction. The same noise floor improvement can be obtained for measurements in the reverse direction by reversing the port 1 coupler (with the corresponding loss of dynamic range for forward measurements).

Using one of these special test set configurations allows you to use a higher and faster IF bandwidth to achieve the same dynamic range compared to a standard test set, so you can use these configurations to get faster measurements even if you don't need the improved dynamic range to test your device's specifications.

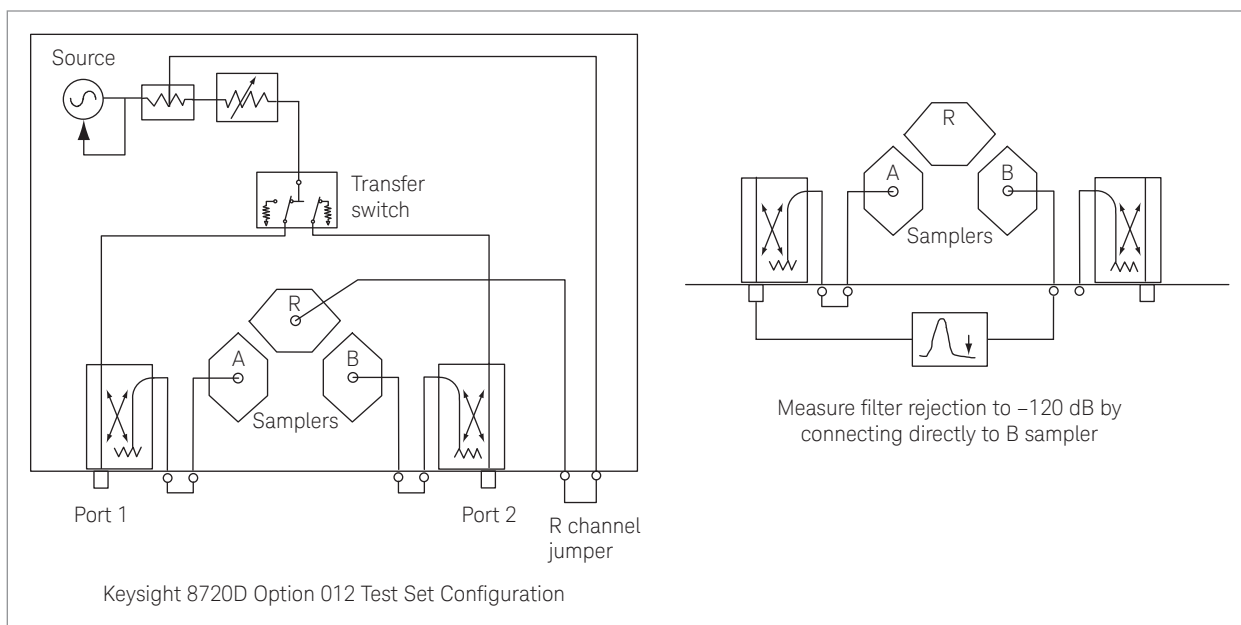

Figure 4. Improving dynamic range with direct sampler access

Source power: Use the highest source power that does not overload the device or network analyzer.

To extend the upper limit on dynamic range, use the highest source power from the network analyzer that will not overload the device under test or cause the analyzer's receiver to overload.

Frequency span: Choose smaller frequency spans that minimize the number of band switches.

Test only the frequency spans that are necessary for your device. Information on the band switch frequencies for each network analyzer can usually be found in the operating or service manual.

Number of points: Use the minimum number of points required for the measurement.

For most analyzers, sweeping fewer points results in less time per sweep. However, network analyzer sources have a maximum sweep rate limited by the hardware. Once this limit is reached, reducing the number of points will not further reduce the sweep time.

List frequency sweep: Use list mode to focus test data where you want it.

List frequency sweep allows you to define an arbitrary list of frequency points at which the analyzer makes measurements. This capability is useful for optimizing sweep time, because you can choose a larger number of sweep points in frequency ranges of interest, while minimizing the number of points for ranges that are not as important.

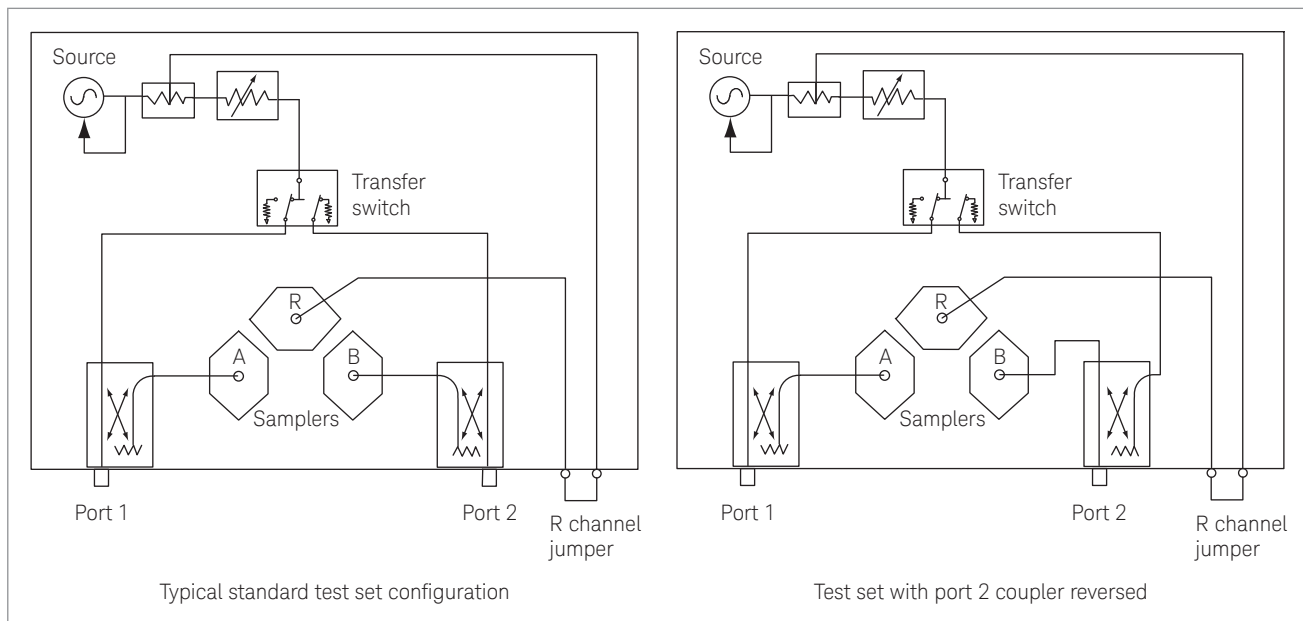

Figure 5. Improving dynamic range with a reversed port-2 coupler

For example, in a filter measurement, you might choose to measure many points in the reject bands and in the passband, but very few points on the skirts of the filter. The frequency list can even skip over frequency ranges where no data is needed. This will enable you to get the detail you want, with fewer total points measured. Also, you can choose to sweep a single segment in the list without losing calibration or needing to interpolate the calibration data.

Some network analyzers such as the Keysight 8753E also offer an enhanced version of this mode that provides two additional features:

- a. Swept list mode:** Many network analyzers normally default to a stepped sweep mode when list frequency is used, which slows the analyzer down. In swept list mode, the network analyzer sweeps a segment instead of stepping the source, resulting in a faster measurement.
- b. Ability to change IF bandwidth and power level for each segment:** For regular list frequency mode, the same IF bandwidth and power level are used for all segments in the sweep. Swept list mode includes a feature that allows you to choose a higher power level and smaller IF bandwidth in segments where better dynamic range is needed, such as in the reject bands of a filter. You can use a wider IF bandwidth and lower power for faster measurements in segments with high-level (low loss) signals, such as in the passband of a filter. The ability to change power levels can be especially helpful for a device such as a filter combined with a low-noise amplifier, where high power is desired for measuring the reject bands, but lower power is needed in the passband to avoid damaging the amplifier or the analyzer's receiver. When the best dynamic range is not needed, you can also use higher power with a wider IF bandwidth for measuring filter stopbands to provide adequate dynamic range while sweeping more quickly.

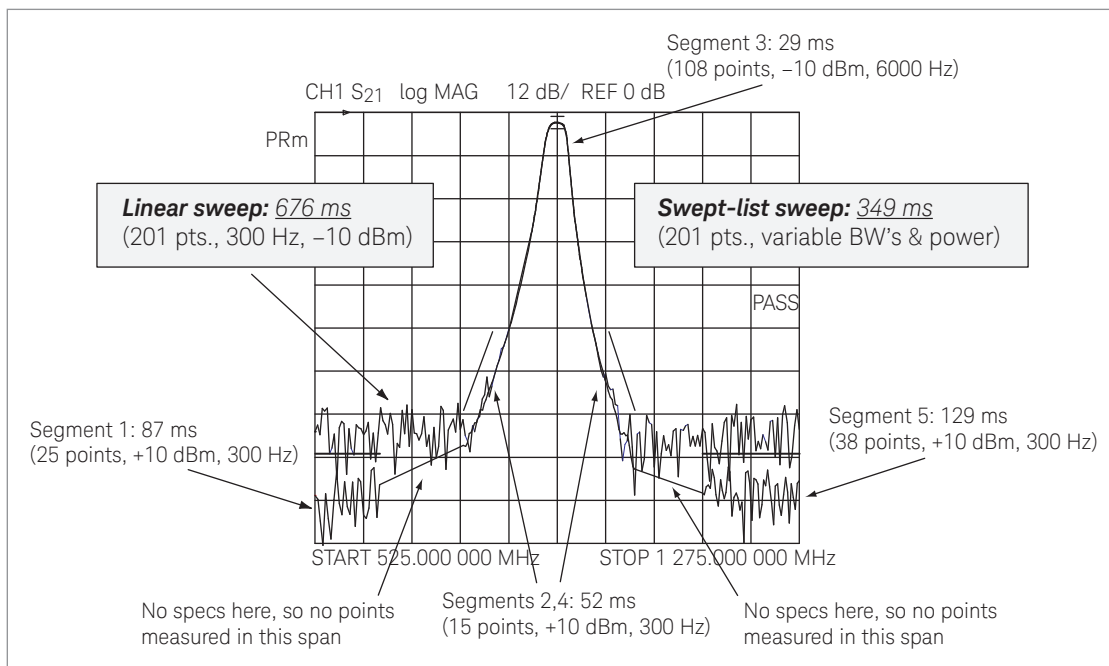

Figure 6. Linear sweep vs. swept list frequency filter measurement

Averaging: Use the minimum number of averages necessary for the measurement.

Averaging can be useful for reducing noise and improving dynamic range. But it might also be helpful to compare the effects of using a narrower IF bandwidth versus averaging to achieve the same noise reduction to see which yields a faster measurement.

Type of calibration: Choose the fastest type of calibration for the required level of accuracy.

For most network analyzers, sweep speed is about the same for uncorrected measurements and measurements done using a response calibration, enhanced response calibration, or one-port calibration. However, sweep speed might be at least twice as slow for a full two-port calibration. A full two-port calibration requires both forward and reverse sweeps to update all four S-parameters for error correction, even when only a single S-parameter is displayed. So, use the calibration that yields the fastest sweep speed for the desired level of accuracy. See the section on Measurement Accuracy for more details.

Fast two-port mode: For faster tuning with full two-port calibration, minimize reverse sweeps.

If a full two-port calibration is used for a tuning application, the sweep speed and trace update time can be improved by using a feature in some Keysight network analyzers called fast two-port mode. Normally, the analyzer will switch the output power sequentially between port one and port two in order to measure all four S-parameters, which is necessary for calculating the corrected results with two-port calibration. This means it takes the analyzer two sweeps (one forward, one reverse) before it can update the trace. With fast two-port mode, you can specify how many forward sweeps the analyzer should take before it switches the power to port two to take the reverse sweep. The analyzer will then update the trace on every forward sweep (using data from the last reverse sweep), until it takes the next reverse sweep. This makes it twice as fast until the reverse sweep is taken. Fast two-port mode can also be used to tune reverse parameters by specifying the number of reverse sweeps to take before the analyzer takes a single forward sweep.

Fast two-port mode provides a more real-time response for tuning. It gives good results because the reverse S-parameters only have a secondary effect on the corrected forward S-parameters. Generally, updating the reverse parameters less often will not cause large errors on the forward parameters. All data is fully error-corrected immediately after the reverse sweep is taken.

Sweep modes

- **Chopped vs. alternate mode: Use alternate sweep instead of chopped mode for better dynamic range.** The default sweep mode in most Keysight network analyzers is chopped mode, in which both input ports are measured when active (using their corresponding samplers) during one sweep by measuring on one sampler and then switching to the other at each point. Chopped mode provides the fastest measurements, but it might not be the best mode in all situations. There is also a mode called alternate sweep, in which only one sampler is measured during a sweep. The analyzer measures the other sampler during the next sweep. Alternate mode is slower, but it provides the best dynamic range by turning off the unused sampler to reduce crosstalk. It is also selected automatically when the measurement channels are uncoupled, so two different instrument states can be measured on the two channels sequentially. Using alternate mode can yield faster results than using a lower IF bandwidth (with chopped mode) to get better dynamic range, or recalling an additional instrument state to make another measurement.
- **Swept vs. stepped sweep: Use swept mode to minimize sweep time when possible.** Many analyzers can also do a frequency sweep in swept mode, stepped mode, or a combination of both, depending on the instrument state settings. Setting the sweep time to “auto” mode (usually the default) causes the analyzer to sweep as quickly as possible for the current settings. Some analyzers also allow you to specifically select either swept mode or stepped mode. Use swept mode when possible, since this will be faster. However, some measurements might require slower sweep time, especially measurements through devices with long electrical delay such as cables or surface acoustic wave (SAW) devices. The slower sweep time can be set either by selecting stepped mode, or by entering a longer sweep time value. You can verify if the device needs a slower sweep time by examining the measurement results using both the faster and slower sweep speeds. If there is no significant difference, then it is acceptable to use the faster setting for that measurement.

Unnecessary functions: Turn off unnecessary functions to reduce sweep time.

Sometimes you turn on a feature when designing a test, but later on you might forget to turn it off when the feature is no longer needed. This might cause the analyzer to take extra time to update information that's not being used. For example, turn off unused markers, averaging, smoothing, limit tests, or measurements of other parameters if they are not needed. For some analyzers, turning off the display in an automated environment might result in faster measurements.

Instrument State Recall Speed

An instrument state is a particular set of stimulus and response parameters that controls how an analyzer makes a specific measurement. It includes the frequency range, number of points, IF bandwidth, power level, and other front panel settings. It may also include calibration data and memory traces. Recalling an instrument state is a quick way to set up an instrument for a particular measurement. The fastest recalls are done from the analyzer's internal memory, but recalls can also be done from a floppy or hard disk file, or from an external controller.

Recall speed depends greatly on the content of the memory register or instrument state that's being recalled. More complicated states will take longer. For example, a simple instrument state with a measurement on one channel only and no calibration can be recalled much faster than one with measurements set up on both channels with full two-port calibration, and limit lines and limit testing turned on. For the Keysight 8753E network analyzer, the recall times for these two states are about 0.5 seconds and 0.9 seconds, respectively (with mostly preset conditions and no optimization). Therefore, it is very difficult to specify a single number for instrument state recall speed. It is best to examine the recall time for the instrument state that is needed for the application.

In many cases, you might see times given for just "recall," rather than "recall with single sweep." These times may be quite different, because at some point, the analyzer needs to take time to actually set up the source and receiver to take a data sweep. If the analyzer is in "hold" mode while the recall is being done, it usually won't take the time to set up for a new sweep. However, as soon as you trigger the analyzer to take a sweep, the analyzer has to do the setup, so the time for a recall with single sweep is often significantly longer than the time for just a recall. Realistically, you will need to know the time for recall with single sweep to approximate your real measurement conditions.

One way to reduce recall time in some network analyzers is to turn off spur avoidance before storing the instrument state. This is a feature in many network analyzers to reduce low-level spurious signals. You can check if this is needed for your measurement by seeing if your data changes with spur avoidance on or off. Turning spur avoidance off allows the analyzer to bypass the calculations and setup that are needed during an instrument state recall, making the recall faster. Similarly, you can turn off other hardware corrections such as sampler correction. If you do, you should calibrate and make measurements under the same conditions so that the calibration can compensate for the lack of hardware correction.

On some newer network analyzers, a very effective way to reduce recall time is to turn the display off, since the analyzer does not spend processing time to display the new instrument state. For example, a typical simple instrument state that takes an 8753E about 0.4 seconds to recall with the display on takes only 0.2 seconds to recall with the display turned off. The amount of speed improvement will vary depending on the instrument state conditions.

If an external controller is being used to control the test, it might be faster or more convenient to use the analyzer's learn string to quickly save the current instrument state or restore a previous state. The learn string is a compact data string that includes the front panel settings, but not calibration or memory trace data. Learn strings might not be compatible between different models of network analyzers, so you need to be careful if your environment includes a mix of network analyzers. For more details, consult the programming manual for your network analyzer.

Recalling an instrument state might not be the fastest way to set up and make a new measurement. For example, with a two-channel network analyzer, you can uncouple the channels and set up two different instrument states on the two channels, such as two frequency ranges or different numbers of points. You will need to check whether it is faster to switch from one channel to the other, or to do an instrument state recall to obtain the second instrument state. Another example is when two instrument states only differ slightly from each other (for example, when you only need to change a few settings from the factory preset state). It might be faster to just change those settings instead of recalling a new instrument state. Automating these changes, with remote commands via GPIB or built-in automation features such as test sequencing, can help make changes easy and repeatable.

If an application requires measurements over a series of different frequency ranges, consider using list-frequency mode instead of instrument state recalls. Each desired frequency range can be set up as a segment in the frequency list. All of the segments can be calibrated at once, and afterwards you can choose to sweep any one of the segments individually, without losing the calibration, instead of having to recall a series of different instrument states.

Automation and Data Transfer Speed

Sooner or later, most production managers consider automating part or all of their test processes to improve throughput. An important part of test process development is deciding what and how much to automate, and deciding on the method of automation. The first decision is whether to use some form of automation internal to the network analyzer or to use some type of external controller. The main choices are:

1. External controller (for example, a PC or workstation)
2. Internal programming language (for example, built-in IBASIC in the Keysight 8711 family of network analyzers)
3. Other internal automation (for example, test sequencing in the Keysight 8752, 8753, or 8720 network analyzer families)

External automation with a controller is probably best if data manipulation or storage is required. In this case there are additional considerations, such as the operating system to use, programming language or software package, and type of GPIB card to install to communicate with the network analyzer. You can use programs such as Keysight VEE that help you write test software quickly, or design your own software in your preferred programming language. This can require training or experience in programming or software.

Internal automation might be easier than external automation in some situations. Often internal automation is easier to learn if there is a keystroke-recording mode that lets a user quickly duplicate a test. Both the 8711's IBASIC and the test sequencing feature in other Keysight network analyzers provide this capability. An internal programming language like IBASIC can be quite powerful, but it does require some programming expertise to use it effectively and go beyond simple keystroke recording. Test sequencing is simpler, but also less extensive, and it is not suitable for data manipulation. However, both forms of internal automation can be quite powerful. For example, you can use either method to program the analyzer's parallel port to control an external test set, read a limit test result, and send an external trigger signal to control a part handler.

Here are some general ideas for improving automation and data transfer speed:

1. Use the analyzer's single sweep mode to ensure that a measurement is complete before starting data transfer. Otherwise, the analyzer might send data to the PC in the middle of a sweep, so the data received by the PC is a mixture of data from the old sweep and the new one.
2. Pick a data format and the associated commands that provide the fastest transfer speeds for the application. The number of bytes per data point that need to be transferred depends on the format. The analyzer's internal format is usually the fastest, but it requires reformatting in a PC to be interpreted. ASCII data transfers are the slowest.
3. Use the fastest data transfer method available. Many Keysight network analyzers have "fast data transfer" commands that may be helpful in certain cases, because they transfer an array as a block compared to the usual byte-by-byte transfer.
4. Transfer the minimum amount of data needed. Users should try different methods to see what yields the fastest results in their application. For example, it might be faster to transfer a trace with only a few points in it (possibly using a frequency list) instead of using markers to read out data. Some analyzers also have a command for obtaining the maximum and minimum values within each limit line segment, which can yield sufficient data.
5. Consider whether error correction should be done internally in the analyzer, or in an external controller. In newer analyzers with faster CPUs, internal calculation time can be faster than the time needed to transfer data out and do the calculation in an external controller. However, in some cases, it might be better to do the error correction externally. One example is for multiport applications where many different calibrations are required for each test device, and there might not be enough room in the analyzer's memory to store all the required correction arrays.

Measurement Accuracy

This application note assumes that the reader has some familiarity with the concepts of measurement errors and error correction or calibration in network analyzers. For more details, refer to the “Applying Error Correction to Network Analyzer Measurements” application note. The appendix also lists other references on calibration.

To review briefly, measurement accuracy (or uncertainty) can be thought of as how close a measurement is to the true or correct value you are trying to measure. No network analyzer is perfect. The factors that contribute to measurement uncertainty can be grouped into the following types of errors:

- Systematic: Caused by imperfections in the test equipment and test setup. These are generally repeatable and can be characterized and removed through calibration (also called error correction).
- Random: Errors that vary randomly as a function of time, including connector repeatability and changes from movements of cables. These cannot be removed by calibration.
- Drift: Errors due to temperature changes or drift over time. These errors can be removed by repeating the calibration.

Network analyzers offer a variety of calibration methods that remove some or all of the systematic errors. Calibration methods that correct more errors also take more time to perform, since more calibration standards need to be measured. More accurate calibrations can also slow down the measurement time, so the user needs to compromise between the desired measurement accuracy and the test process speed (including calibration time).

How often to calibrate is another issue. Recalibration will correct for drift errors, which may be caused by changes in the hardware over time, temperature changes in the environment, or changes in the test setup such as movement of cables. How often a new calibration is required will depend mostly on the environment and the desired level of accuracy. Many users perform validation checks by measuring a verification device. If the measurement falls within acceptable limits, the previous calibration is still considered good. Keysight provides verification kits that contain devices with factory-measured data that can be used for this purpose.

The level of accuracy that is required depends on the application (tuning vs. final test) and the specifications of the device under test. Better accuracy means lower measurement uncertainty, so you can reduce guard bands and still have less likelihood of incorrect pass/fail results. Tighter guard bands improve throughput by allowing more devices to pass without sacrificing quality. These same devices might have failed test limits based on wider guard bands when they were actually good devices.

For applications that do not require the highest accuracy, analyzers with transmission/reflection test sets, such as the 8711C family or the 8752C, can be an economical solution. These analyzers offer the types of calibration methods listed in the table below. The time required for performing the calibration will vary depending on the number of calibration standards that need to be measured.

Calibration type	Errors corrected	Number of standards required
Response	Reflection OR transmission: Frequency response/tracking	1
Response and isolation	Reflection: Tracking and directivity OR Transmission: Tracking and crosstalk	2
One-port	Reflection only: directivity, source match, and reflection tracking	3
Enhanced response (Available only in newer Keysight network analyzers such as the 8711C family)	Transmission: tracking and source match AND Reflection: directivity, source match, and reflection tracking	4

These calibration methods are good for improving throughput because they have almost no impact on sweep speed, and the calibrations themselves are quick and easy to perform. Since these methods only correct for some of the errors that might be present in a measurement, they are best suited to certain types of devices. For example, devices that have very good input and output match will be less affected by source and load match errors, so response or one-port calibrations can yield good results. One-port calibrations can also yield good results for devices with high loss in the transmission path or high isolation between ports. However, a device that has low insertion loss will have its measurements affected by source and load match errors. For example, a filter that has low insertion loss in its passband will show ripples in the measurement due to these errors. Some of these ripples might have peaks with magnitudes greater than 0 dB, indicating gain in a passive device, which is clearly an error.

For better accuracy, a network analyzer with an S-parameter test set is needed, such as the 8753 or 8720 families. These systems can provide full two-port error correction such as short-open-load-thru (SOLT) calibration. SOLT calibration corrects for twelve errors: reflection tracking, directivity, source match, transmission tracking, load match, and crosstalk, in both the forward and reverse directions. Twelve measurements need to be made (using four known standards) to correct for all of these errors, so it takes longer to perform a calibration (although the two measurements required for the crosstalk correction can be omitted if the measurement does not require a low noise floor). This type of calibration provides the best accuracy, but it does require the analyzer to take both a forward and reverse sweep to update all four S-parameters for each updated measurement display. Two-port calibration will slow down the perceived sweep speed, since it effectively takes two sweeps for every trace update instead of one.

Another form of two-port calibration uses through-reflect-line (TRL) standards. This method is primarily used in noncoaxial environments such as measurements in test fixtures or on-wafer. It requires a network analyzer with four receivers, such as the Keysight 8720D with Option 400 or 8510C. There are a number of variations of TRL calibration, including TRL* for network analyzers with only three receivers, LRM using line-reflect-match standards, or TRM using through-reflect-match standards. From a throughput standpoint, TRL calibration (and its variations) have the same effect on sweep speed as a full two-port calibration, because it also requires measurement of all four S-parameters to calculate corrected data for each displayed sweep update.

When performing two-port calibrations, you may need to perform the isolation portion of the calibration for the best dynamic range. For isolation, at least 16 averages are recommended. Turn averaging on only during the isolation portion if you do not need it for other calibration standards. Turn averaging off prior to finishing the calibration. This will allow you to make measurements at the faster conditions (with no averaging) without the analyzer indicating that conditions have been changed after the calibration was complete.

A quick check on whether accuracy is being compromised for sweep speed can be done by making a measurement with the settings for the best accuracy, saving the results as a memory trace, then changing the settings or calibration type, and comparing the new results with the memory trace.

Note that for the best accuracy, it is necessary to perform a calibration as close to the actual measurement plane as possible. For example, for an on-wafer measurement, the setup might include an S-parameter test set, test port cables, and a wafer probe station. The calibration should be performed on-wafer using a calibration substrate in order to remove systematic errors caused by all the components between the network analyzer and the wafer probe tips.

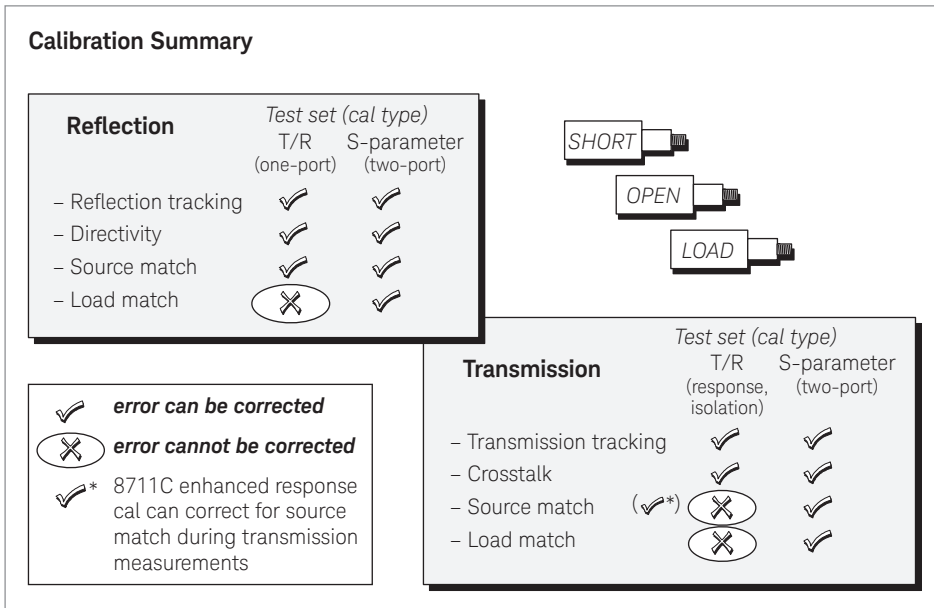

Figure 7. Correctable errors for different test sets and calibration types

Some devices have connectors that make them “noninsertable,” meaning that the connectors are the wrong type to fit in place of a zero-length through connection between the test-port cables. The connectors can have the same type and sex on each port, or they can be different types, such as type-N on one side and 3.5 mm on the other. One way to calibrate in this situation is the swap-equal-adapters method, which uses one adapter to perform the transmission calibration, but a different adapter for the reflection calibration and actual measurement. The two adapters need to be as equal as possible, especially in loss, electrical length, and match.

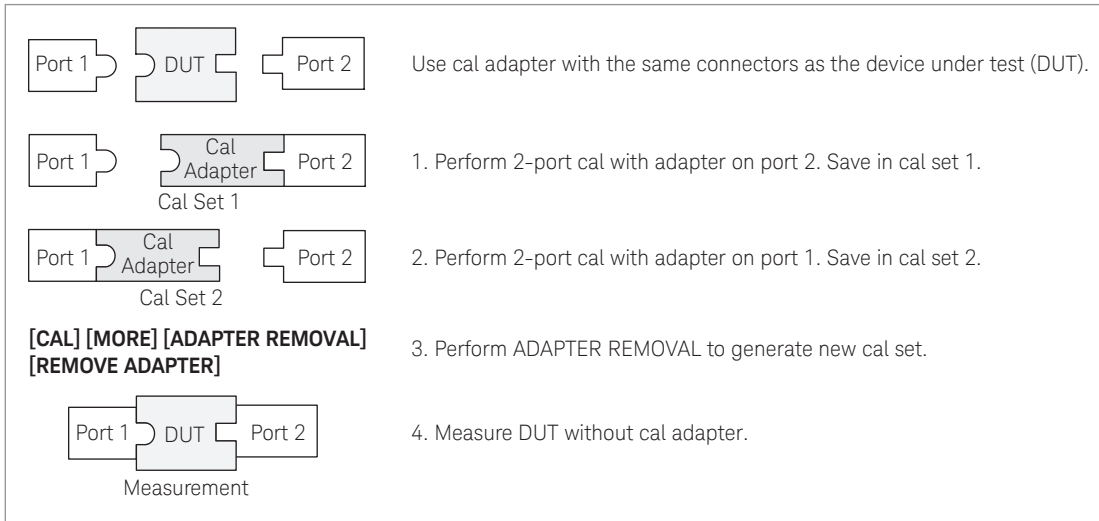

Figure 8. Adapter-removal calibration procedure

A more accurate way to perform calibrations for noninsertable devices is to use adapter-removal calibration. Figure 8 outlines the main steps for performing this procedure. The electrical length of the adapter must be specified within one-quarter wavelength (entered as a time value, similar to electrical delay). Type-N, 3.5-mm, and 2.4-mm calibration kits for the Keysight 8510 and 8720 family network analyzers contain adapters that are specified for this purpose. Refer to the operating manual or on-screen help text (for the 8753 and 8720 network analyzers) for more information.

Device Connection Time

The time needed to disconnect a device and connect a new one can be a significant portion of the total test process time, especially for multiport test devices. Most test processes will include one or more of the following:

- Manual connections
- Part handlers
- Multiport devices

For two-port devices that are measured with a transmission/reflection test set, the user must manually turn the device around in order to make measurements in the reverse direction. Users can save time by using switching test sets, which can switch the output power to either port so both forward and reverse measurements can be made with a single connection. (Note that switching test sets generally do not offer additional error correction capability, so these measurements are still less accurate than those made with an S-parameter test set.)

If manual connections are being used for a two-port device, it is possible to speed up the connection time using a part handler to automate the process. Gravity-feed part handlers tend to be faster and less expensive than pick-and-place part handlers, but they are more limited in the types of device packages they can handle. Using a part handler generally requires a custom test fixture, which adds development time and can also add calibration time, so this might not be helpful in all situations. For devices that require coaxial connections, push-on connectors can make the connection faster, but they will be less repeatable and can result in more measurement uncertainty.

Special test fixtures that allow a user to connect devices more quickly can be useful, with or without a part handler. Many companies make their own fixtures since they have many custom packages for their devices. When designing a test fixture, it is important to have good RF performance (low loss and low parasitics), and ease of calibration within the fixture should be considered. Because of the difficulty in making good RF fixtures, full two-port calibration is generally required, requiring a set of in-fixture calibration standards. There are some vendors who specialize in making test fixtures and calibration standards. The appendix contains some references for vendors and more information on designing and calibrating fixtures.

If you already use a part handler, the easiest way to speed up connection time is to use a faster part handler, although that will probably be more expensive. Another improvement is to consider using the analyzer's internal automation capability to control the part handler, instead of relying on an external controller, as described in the section on "Automation and Data Transfer Speed." Using internal automation can be faster since no data has to be transferred outside of the analyzer before a decision can be made and a command sent to the part handler.

For multiport devices, some operators use the analyzer to test two ports at a time, with terminations at the unused ports, and then switch the cable connections around to make the other necessary measurements. For devices with many ports, this process can be very tedious and time-consuming, and it can also contribute to operator fatigue.

One alternative is to use a multiport test set that allows the operator to make connections to all of the ports once, and then have the analyzer make all necessary tests without changing connections. Keysight provides a variety of test sets for its network analyzers, including the 8753D Option K36 three-port duplexer test set (also available for the 8711, 8752C, and 8720 families), the 87075C 75 ohm multiport test sets with the innovative "SelfCal" feature for the 8711C family, and the 87050A/B series of 50 ohm test sets for the 8711, 8753, or 8720 families. Other test set designs provide two sets of test ports for one network analyzer, so that the operator can connect a new device while another device is being tested.

Some vendors offer multiport solutions for Keysight network analyzers. For example, the SPTS-4 four-port S-parameter test system from ATN Microwave (see Appendix) provides full four-port error-corrected measurements with an 8753 network analyzer. Users can also build their own test sets to switch signals to and from the network analyzer to the proper ports of the test device.

Instrument Uptime

Many people overlook an instrument's availability when considering throughput, but it is actually a very important part. A fast network analyzer has little value if the analyzer breaks or has to be sent out for service or maintenance frequently, causing a production line to shut down, or requiring arrangements for spare instruments. When making a purchase, consider instrument quality, expected failure rate, calibration interval, and turn-around time for repair or calibration, all of which add to the maintenance cost. The location of the nearest service center and the availability of on-site repair are some of the factors in the turn-around time.

Product Quality

Making measurements faster and increasing throughput is not the only concern for manufacturing companies. Many companies are also using techniques like statistical quality control (SQC) or continuous process improvement (CPI) to improve the quality of their products and to reduce waste (and lower costs) by finding problems earlier in the manufacturing process. Network analyzers can help with this task by providing an efficient interface for data collection. Examples include providing hardcopy printouts, saving data to disk files in easy-to-use formats, or fast transfers of data to an external controller.

Traceability of a test instrument's performance is important to ensure quality, especially if your company is ISO-9000 compliant. If you are relying on a certain level of performance from the analyzer in order to make your measurements, it is important to note whether these are guaranteed instrument specifications or only "typical" instrument performance values that might vary from one analyzer to another. Variation in instrument performance will affect the consistency and repeatability of measurements made on different production lines.

Another issue is whether the network analyzer's specifications are sufficiently complete to determine the accuracy of your measurements. Some network analyzers only specify the dynamic accuracy, the uncorrected systematic errors, or the residual errors after a calibration. However, having only one of these specifications is not enough to determine total measurement uncertainty. To get the total measurement uncertainty for a calibrated transmission or reflection measurement, you need to combine the effects of dynamic accuracy with other system errors such as the residual systematic errors. Most Keysight network analyzers provide graphs of the total measurement uncertainties for a test system based on particular test port connectors.

Conclusion

The task of improving throughput while maintaining product quality requires the consideration of many different aspects of the network analyzer and the test device, besides the most obvious data sheet items such as the microseconds per point sweep speed. Optimizing the important areas for each application can provide a more thorough and effective way to improve overall throughput. The following checklist is a brief summary of the key points presented in this application note.

Checklist for Increasing Measurement Throughput

Sweep speed

- Use the widest IF bandwidth with acceptable dynamic range and trace noise
- For better dynamic range, change setup to bypass coupler loss
- Use the highest source power that does not overload the device or network analyzer
- Choose smaller frequency spans to minimize band switches
- Use the minimum number of points
- Use swept list mode, including setting IF bandwidth and power for each segment
- Minimize use of averaging, and compare speed of averaging vs. using smaller IF bandwidth
- Choose the fastest type of calibration for required level of accuracy
- For tuning while using full two-port calibration, try fast two-port mode to minimize reverse sweeps
- Try using alternate sweep instead of chopped mode for improving dynamic range
- Use swept mode instead of stepped mode and minimize sweep time when possible
- Turn off unnecessary functions like markers, averaging, smoothing, limit tests, unused parameters

Instrument state recall

- Turn off spur avoidance and hardware corrections
- Turn off display (for newer network analyzers)
- For automated test, try using learn strings instead of recalling instrument states
- Consider using uncoupled channels to set up two instrument states instead of using a recall
- Consider using list frequency mode instead of recalling instrument states with different frequency ranges

Automation and data transfer

- Consider using internal automation where possible
- Use fastest data format for data transfers
- Use any available fast data transfer commands
- Transfer minimum amount of data needed
- Consider whether to use internal error correction or to use an external computer for calculations

Measurement accuracy

- Use calibration type that gives you the best compromise between measurement speed and accuracy
- Calibrate as close to the device under test as possible
- Use adapter-removal calibration where appropriate

Device connection

- Part handlers may speed connection time, but will probably require test fixtures
- Be aware of fixture design and calibration considerations
- Consider using multipoint test sets to simplify connections

Instrument uptime

- Choose analyzer with low failure rate, fast turn-around time, and reasonable cost for repairs and calibrations

Maintaining product quality

- Use easiest ways to collect necessary data from the analyzer (printouts, data transfers to PCs, etc.)
- Make sure analyzer has necessary specifications to guarantee the desired level of accuracy

Appendix

Related Keysight Application Notes

Understanding the Fundamental Principles of Vector Network Analysis, Application Note

Exploring the Architectures of Network Analyzers, Application Note

Applying Error Correction to Network Analyzer Measurements, Application Note

Network Analyzer Measurements: Filter and Amplifier Examples, Application Note

In-fixture Microstrip Device Measurements Using TRL Calibration*, Application Note

Specifying Calibration Standards for the Keysight 8510 Network Analyzer, Application Note

Applying the Keysight 8510 TRL Calibration for Non-Coaxial Measurements, Application Note

Measuring Noninsertable Devices, Application Note

Suggested reading

"Design of an Enhanced Vector Network Analyzer," Frank David et al., Hewlett-Packard Journal, April 1997.

"Calibration for PC Board Fixtures and Probes," Joel Dunsmore, 45th ARFTG Conference Digest, Spring 1995.

"Techniques Optimize Calibration of PCB Fixtures and Probes," Joel Dunsmore, Microwaves & RF, October 1995, pp. 96–108, November 1995, pp. 93–98.

"Improving TRL Calibrations of Vector Network Analyzers,"* Don Metzger, Microwave Journal, May 1995, pp. 56–68.

"The Effect of Adapters on Vector Network Analyzer Calibrations," Doug Olney, Microwave Journal, November 1994.

Third-Party Companies

Test fixtures

Inter-Continental Microwave
1515 Wyatt Drive
Santa Clara, CA 95054-1524
USA
E-mail: icmfixture@aol.com
Phone: (408) 727-1596
Fax: (408) 727-0105

Multiport test sets

ATN Microwave, Inc.
85 Rangeway Road
North Billerica, MA 01862-2105
USA
E-mail: info@atn-microwave.com
Phone: (978) 667-4200
Fax: (978) 667-8548
www.atn-microwave.com

Wafer probes and stations

Cascade Microtech
14255 SW Brigadoon Court
Beaverton, OR 97005
USA
E-mail: sales@cmicro.com
Phone: (503) 626-8245
Fax: (503) 626-6023



myKeysight

www.keysight.com/find/mykeysight

A personalized view into the information most relevant to you.

Note: this document was formerly known as Application Note 1287-5

For more information on Keysight Technologies' products, applications or services, please contact your local Keysight office. The complete list is available at: www.keysight.com/find/contactus

Americas

Canada	(877) 894 4414
Brazil	55 11 3351 7010
Mexico	001 800 254 2440
United States	(800) 829 4444

Asia Pacific

Australia	1 800 629 485
China	800 810 0189
Hong Kong	800 938 693
India	1 800 112 929
Japan	0120 (421) 345
Korea	080 769 0800
Malaysia	1 800 888 848
Singapore	1 800 375 8100
Taiwan	0800 047 866
Other AP Countries	(65) 6375 8100

Europe & Middle East

Austria	0800 001122
Belgium	0800 58580
Finland	0800 523252
France	0805 980333
Germany	0800 6270999
Ireland	1800 832700
Israel	1 809 343051
Italy	800 599100
Luxembourg	+32 800 58580
Netherlands	0800 0233200
Russia	8800 5009286
Spain	800 000154
Sweden	0200 882255
Switzerland	0800 805353
	Opt. 1 (DE)
	Opt. 2 (FR)
	Opt. 3 (IT)
United Kingdom	0800 0260637

For other unlisted countries:
www.keysight.com/find/contactus
(BP-09-23-14)