

Keysight Technologies

Educational Overview of RF Power Measurement and Applications

Application Note

Burst power signal



Introduction

Understanding RF power measurement and its applications is fundamental for anyone studying RF and microwave engineering courses. This application note covers a wide range of RF power measurement-related topics with the objectives of helping students understand the basics of RF power and the importance of RF power measurement, providing some common course curriculum RF power measurement application examples, and explaining common instrumentation used to measure RF power.

Why Measure RF Power?

DC/AC versus RF power

In the AC and DC electronic/electrical world, which operates below the 100 kHz range, voltage and current are the two main parameters that are measured. The voltage and current are typically simple sinusoidal waveforms. Power is calculated from the voltage across the impedance, or by multiplying the voltage and current, as shown in Figure 1 below.

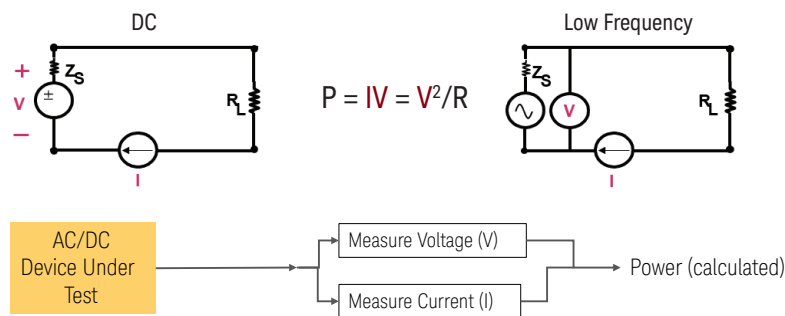

Figure 1. AC/DC system power measurement

As the frequency increases towards radio frequencies (RF) or the microwave range, deriving the RF power from the voltage and current becomes difficult to measure for a variety of reasons. As the frequency increases and the wave length shortens, they are affected by factors such as phase difference and impedance type. Signal modulation results in complex waveforms, which make it even harder to measure the voltage and current accurately. Consequently, direct RF power measurement is more practical and useful for all kinds of RF and microwave applications, test, and measurement. In fact, power is the most frequently measured RF quantity.

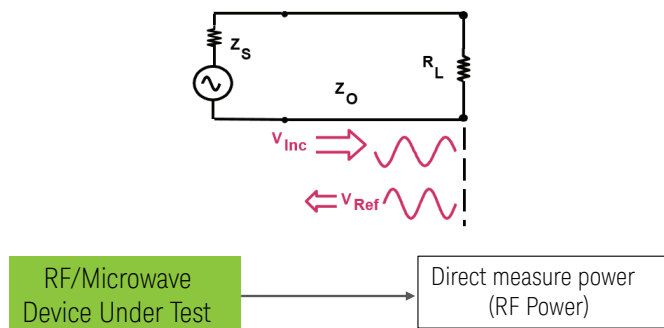

Figure 2. RF system power measurement

RF power measurement unit (W, dB, dBm)

The basic measurement unit of RF power is watt (W). Next, there is the decibels measurement unit, dB, which is basically a power ratio measurement, as shown in Equation 1. P is the intended RF power to be measured, and P_{ref} is the reference RF power. In some applications, decibels is also used where relative power measurement is required.

$$P(\text{dBm}) = 10 \log\left(\frac{P}{P_{ref}}\right) \quad \text{Equation 1}$$

$$P(\text{dBm}) = 10 \log\left(\frac{P}{1\text{mW}}\right) \quad \text{Equation 2}$$

How RF power measurement impacts ordinary people

In the current wireless world, we use a large amount of RF and wireless gadgets such as mobile phones, tablets, PC/laptops, *Bluetooth*[®] headsets, and smart wearable devices. All these devices transmit and receive RF signals to or from other devices (or infrastructure). RF power measurement quantifies how much RF power these devices are transmitting or receiving.

If the receiving power is too low, these devices are typically unable to receive the intended signal accurately. For example, if the receiving power or signal on our mobile phone is too low, we are not able to hear conveyed messages properly – typically it is too noisy to hear the voice or message on the phone. If the transmitting power is too high, the transmitted signal can interfere with other RF or wireless devices in near proximity, as shown in Figure 3.

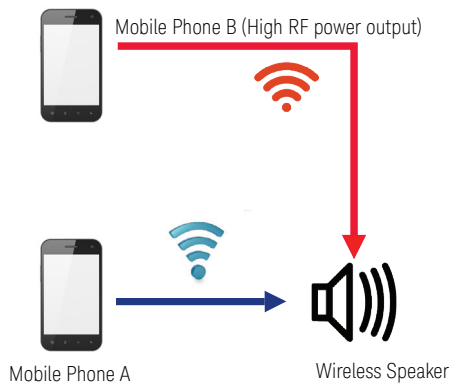

Figure 3a. High RF power interference

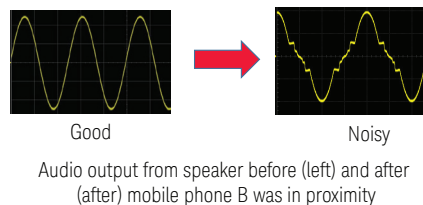

Figure 3b. Impact to audio output from speaker

RF Power in Electrical/Electronic Engineering Courses

In general electrical and electronic engineering study, there are various subjects that directly or indirectly involve RF power measurement (see Figure 4).

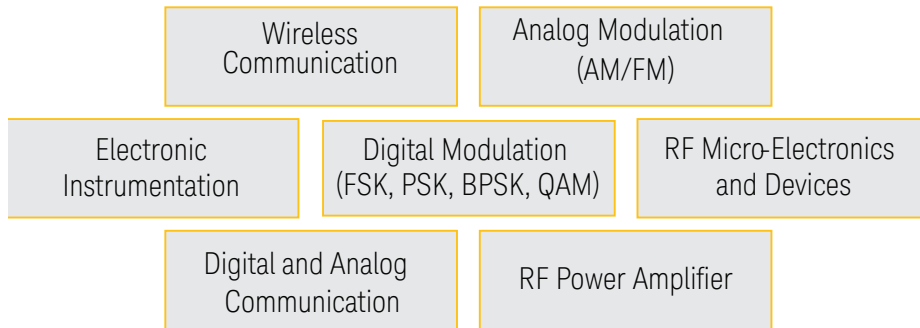

Figure 4. Subjects that involve RF power measurement

Analog modulation (AM/FM)

In the study of analog modulation, students learn about the fundamental techniques and signal behavior of the amplitude modulation (AM) and frequency modulation (FM). There is a need to understand the RF power that is being transmitted or received by the AM or FM circuits. For example, in AM transmitter circuit study, students often need to know how the AM depth affects the transmitted RF power, as illustrated in Figure 5.

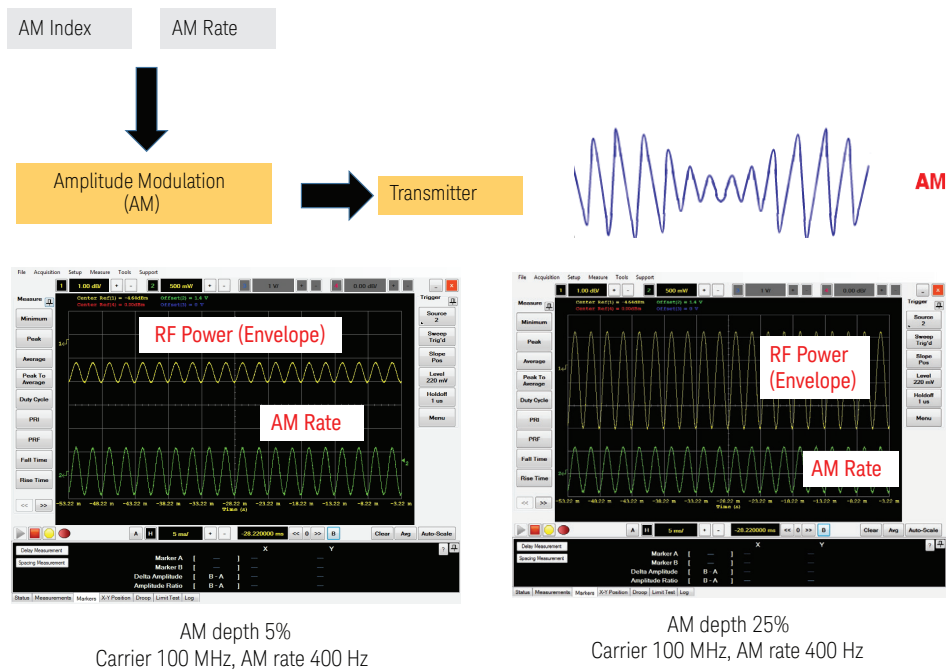

Figure 5. AM transmitter RF envelope power measurement (time based) with various AM rates

Wireless communication RF transceiver

In wireless communication studies, particularly on the subject of RF transceivers, an RF power meter is used to measure the output power of the transceiver, as shown in Figure 6. Students can also use the RF power meter to understand the impact on transceiver output using different digital modulation schemes. Different digital modulation schemes, such as BPSK (binary phase-shift keying), QPSK (quadrature phase-shift keying), QAM (quadrature amplitude modulation), and others, each have their own characteristics that can affect the transmitter output peak-to-average ratio (PAR) or the transmitter output crest factor.

Some RF power meters provide the complementary cumulative distribution function (CCDF) plot feature (Figure 7). The CCDF is a plot of probability versus peak-to-average ratio (PAR), which characterizes the statistical power of a signal. CCDF is one of the important measurements used in designing RF transmitters, especially power amplifiers that must be capable of handling high PAR signal exhibits while constantly maintaining good adjacent-channel leakage performance. The CCDF plot is primarily used in the wireless communication market for evaluating multicarrier power amplifier performance. It measures the percentage of time when the PAR is at or exceeds a specific power level.

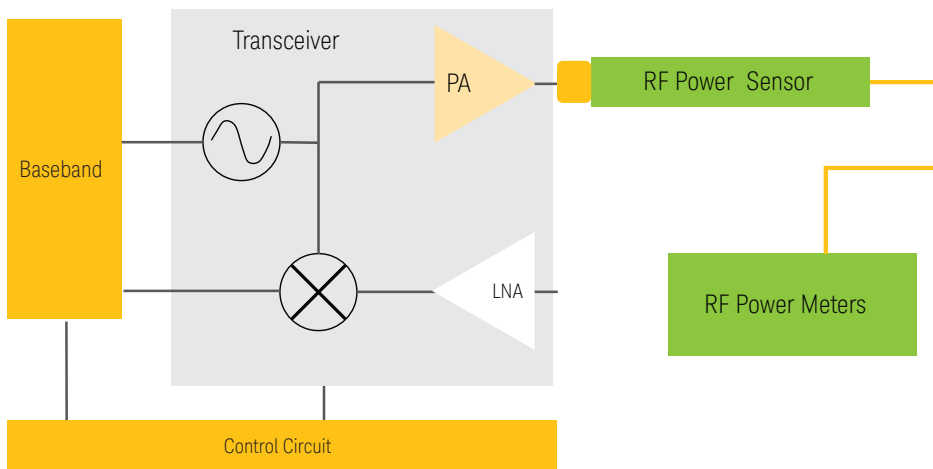

Figure 6. Transceiver power output measurement

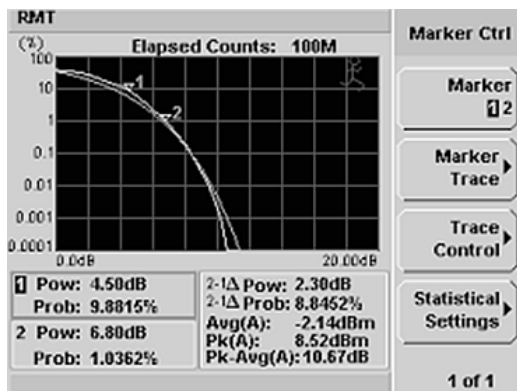

Figure 7. RF power CCDF plot

RF power amplifier

RF amplifiers are another subject in the electronic and RF communication field. There are a few important parameters or characteristics of RF amplifiers. These include gain, power output, linearity, 1-dB gain compression (P1dB), frequency response, bandwidth, efficiency, and noise. RF power meters and sensors can be used to measure and analyze some of these parameters, such as the output power, gain, linearity, and 1P1dB.

P1dB is perhaps one of the most common specifications found on RF amplifier data sheets. P1dB is the point where the output power drops to 1 dB from the linear line, as shown in Figure 8. When the input RF power increases, there is a linear increase in output RF power. This continues until the amplifier goes into compression, when the output power starts to decrease or stay flat. It is important to know the P1dB point so that the input power levels can be restricted to prevent distortion.

A simple P1dB test setup using RF power meters is shown in Figure 9. Two RF power meters and sensors are used: one at the input and the other at the output. The test can be done manually or it can be automated using an external program that controls the power step of the input RF power (from a RF signal generator or synthesizer) and retrieves the readings from the RF power meters. The results are then can be tabulated as shown in Table 1 and the plot the P1dB graph as shown.

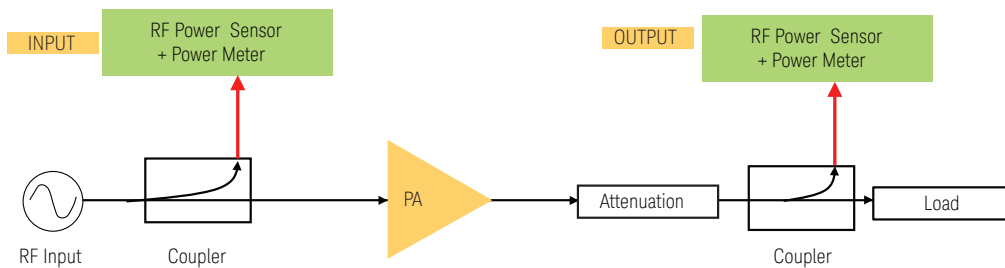

Figure 9. Gain and P1dB test

Table 1 Pin, Pout and Gain

P_{input} (dBm)	P_{output} (dBm)	Gain (P_{output}/P_{input}) -dB
-30	-10	20
-25	-5	20
-20	0	20
-15	5	20
-10	10	20
-5	15	20
0	20	20
5	25	20
10	30	20
15	34	19

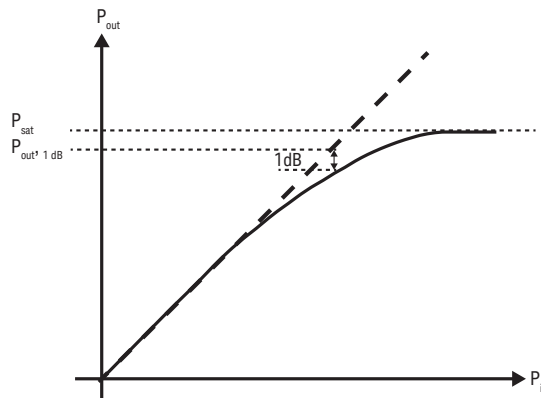

Figure 8. P1dB plot

Scalar network analysis measurement

Two-port network analysis is an interesting subject when trying to understand the concept of network analysis and the theory of scattering parameters, or simply, S-parameters. S-parameters are a powerful way to describe an electrical network, RF devices, or components such as filters, couplers, and mixers. S-parameters change with frequency, load impedance, and source impedance. S-parameters analysis consist of amplitude and phase information. As shown in Figure 10, two-port network analysis measurements are normally done using a network analyzer, to find the S-parameters.

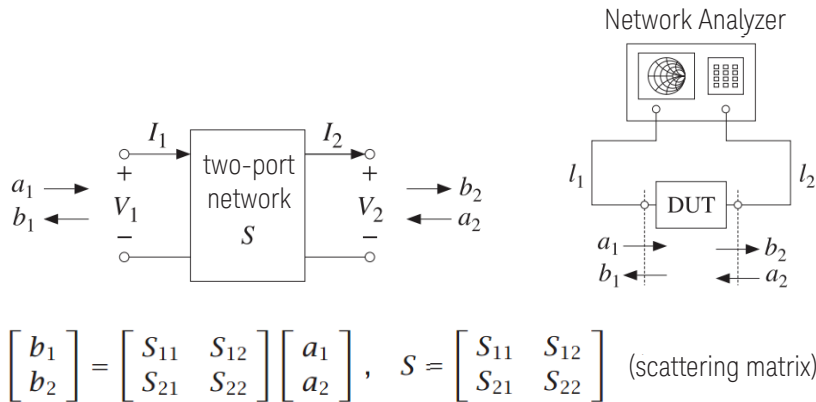

Figure 9. Gain and P1dB test

However, there is an easy way to conduct a simple scalar network analysis using RF power meters and sensors to obtain the S11 and S21 scalar parameters. There is a free scalar network analysis (SNA) software application that can be used with some of the RF power meters or USB RF power sensors, which allows users to perform simple gain or return loss of any two-port device. A measurement setup example of gain and return loss analysis on a two-port device under test (DUT) is shown in Figure 11. An RF coupler is required to measure the reflected RF power.

In the setup shown, S11 and S21 is analyzed through a frequency sweep on the RF signal generator. The S11 is the return loss and the S21 is the gain of the DUT. The SNA software (Figure 12) provides a step-by-step guide on how to perform the connection configuration zero and short calibration. The SNA measurement solution is an economical and helpful tool for students learning the basics of S-parameters and scalar network analysis.

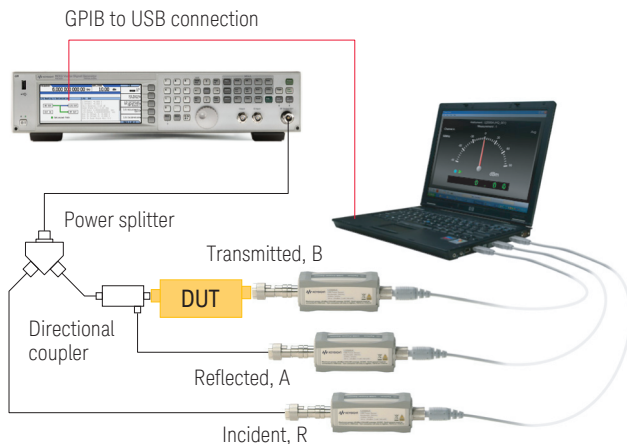

Figure 11. Example of using USB RF power sensors for SNA measurement

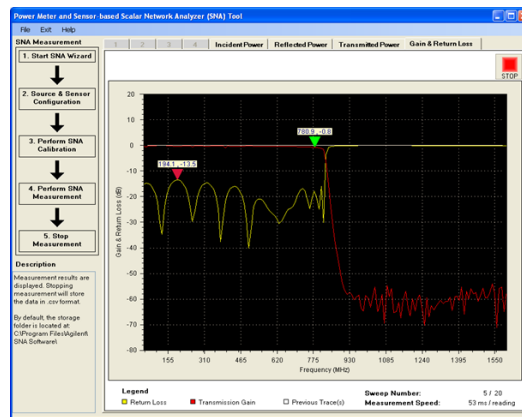

Figure 12. SNA software

RF pulse timing analysis

In some wireless communication protocol studies, such as W-CDMA (wide-band code division multiple access) or LTE (long term evolution), it is important to understand the RF pulse behavior in both the time and frequency domains. The RF power meters and sensors can be used to show the RF pulse timing and measure the required “time-gated” power as shown in Figure 13. Using advance functions such as the marker measurement or zoom function, users can specifically measure the RF power at the required timing.

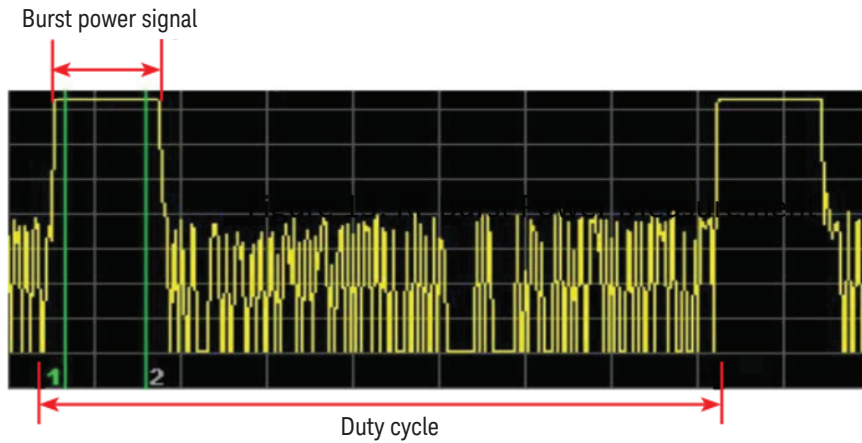

Figure 13. RF burst power measurement

Radar technology study and research also requires such measurement and analysis functions in RF power meters. For example, in wide-band radar pulse amplifier research, a few pulse parameter measurements such as rise time, fall time, pulse width, pulse top, and overshoot are required. Figure 14 shows how a high-bandwidth RF power meter performs these pulse parameters on a radar pulse, in time domain.



Figure 14. Radar pulse parameters (timing) analysis

RF Power Instrumentation: RF Power Meter and Power Sensors

What is an RF power meter and sensor?

There are a few test instruments used to measure RF power, including RF power meters and sensors, spectrum analyzers, and network analyzers. Of these tools, the RF power meter with sensors is the simplest instrument and it is relatively easy to setup and operate.

Currently, there are two form factors of RF power meters commonly available in the marketplace as illustrated in Figure 15. The first is the conventional RF power meter and its relevant sensors. Users can freely choose the RF power sensors based on their measurement needs. The second form factor is the USB (powered) RF power sensor. This device is both the power meter and sensor, in small, compact, and handy form factor, which eliminates the need for a bulky power meter. USB RF power sensors can be powered by a computer or other compatible test instruments.



Figure 15. RF power meter and sensors form factors

A power meter essentially measures the power of RF signals. The RF power measurement, as mentioned earlier, is a 50-ohm terminating type measurement. The RF power sensor uses a broadband detector and reports absolute power usually in watts and dBm. Power meters provide the best accuracy of any RF instrument for measuring power, typically in the range of ± 0.2 dB.

Time domain versus frequency domain (spectrum analysis)

RF power meters analyze and measure RF power in the time domain. Some higher-end RF (peak) power meters also can perform time-gated measurement within an RF pulse, the same way as it is done using a digital oscilloscope (shown in Figure 16). An RF power meter, unlike a spectrum analyzer, does not perform power-versus-frequency analysis or frequency spectrum analysis.

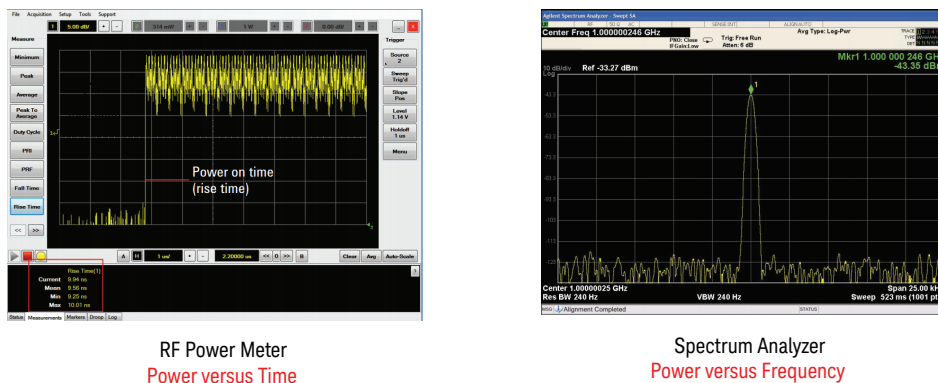

Figure 16. Time versus frequency domain

Overview of RF power meter and sensor architecture

Figure 17 shows the basic method of measuring high-frequency power using a power meter and power sensor. The power sensor converts high-frequency power to a DC or low-frequency signal that the power meter can measure and relate to an RF power level. The meter displays the detected signal as a power value in dBm or watts.

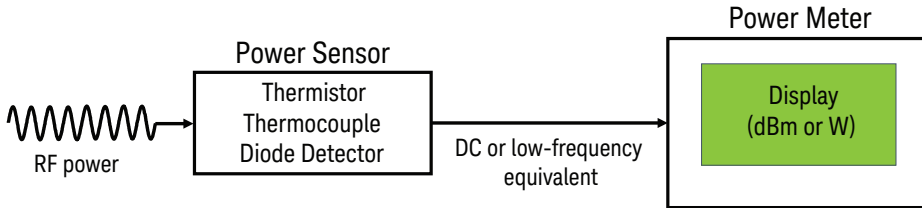

Figure 17. Basic RF power and sensor system overview

The three main types of sensors are thermistors, thermocouples, and diode detectors. There are benefits and limitations associated with each type of sensing element. Table 2 shows a brief comparison of these three types of RF power sensor technologies.

Table 2. Comparison between various power sensor technologies

	Advantage	Limitation
Thermistor	<ul style="list-style-type: none"> – Super accurate 	<ul style="list-style-type: none"> – Narrow dynamic range (typically 40 dB) – Slow measurement response – Highly sensitive to ambient temperature
Thermocouple	<ul style="list-style-type: none"> – Good dynamic range – Superior linearity (DC voltage to RF power plot) 	<ul style="list-style-type: none"> – Only good for average RF power measurement
Diode	<ul style="list-style-type: none"> – Wider dynamic range (typically >55 dB) – Fast measurement response – Good for peak and average RF power measurement 	<ul style="list-style-type: none"> – Needs more linearity correction in the RF power meter

Key Specifications to Consider When Choosing an RF Power Meter and Sensors

There are numerous RF power meters and sensors on the market available from different manufacturers with various features, functions, and performance. This section discusses some key points to consider to help you determine which one to use for your application.

Frequency and dynamic range

Since an RF power meters are not able to measure the carrier frequency of the signal, it is important to begin with a knowledge of the signal frequency. It is also useful to understand the range of the RF signal power level. The frequency and power level information are crucial to choosing the right RF power meter and sensors.

The RF power sensors on the market have different frequency ranges and dynamic ranges. Dynamic range is the difference between the maximum and the minimum RF power level, which a sensor can measure. Different types of RF power sensors have different dynamic ranges. Typically, the lowest power level a sensor can measured is around -70 to -60 dBm, while the maximum level is about $+20$ dBm. A typical RF power sensor's dynamic range will be around 80 to 90 dB.

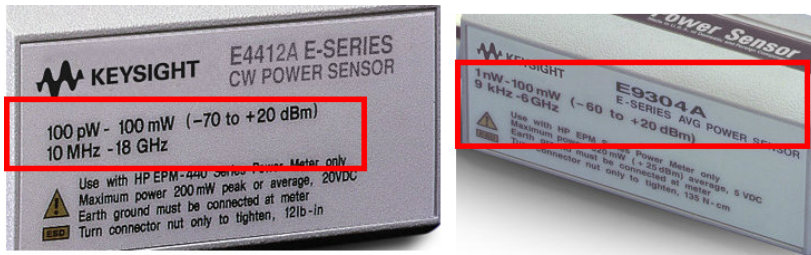

Figure 18. Frequency and dynamic range information on RF power sensors

Average power-only, or peak and average?

It is also important to understand what kind of RF signal you will be trying to measure with the RF power meter. The RF signal could be just a high frequency sine wave or analog modulation signals (AM/FM) which were described in earlier. There are also RF signal with complex wireless modulation such as WiFi, Bluetooth, W-CDMA, or LTE. Some applications may include the need to analyze and measure RF pulses from a power amplifier.

In most of the application cases, there is only the need to measure average RF power. Average power is the most common power measurement. As illustrated in Figure 19, an RF power meter can measure any type of RF signal that is a CW (continuous wave) of a single frequency signal or any type of modulated RF signal.

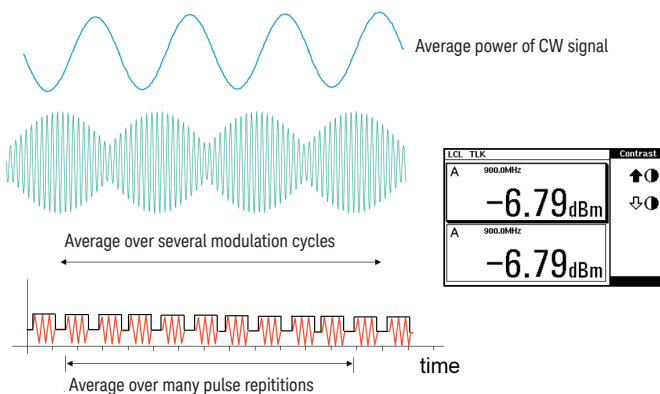

Figure 19. Average power measurement on various types of RF signals

However, as a signal becomes more complex, peak envelope power (PEP) or simply the RF peak power measurement is also required. The RF peak power is a measure of the maximum signal power as shown in Figure 20. Only a peak power meter can perform RF peak power measurement. There is also the bandwidth consideration when choosing the suitable peak power meter. The bandwidth is the baseband bandwidth of the RF signal to be measured. For example, 2G mobile communication signals (GSM or EDGE) have only a few hundred kHz of bandwidth. Whereas, 3G or 4G mobile signals have MHz of bandwidth. Commercially-available RF peak power meters will specify these bandwidth capabilities.

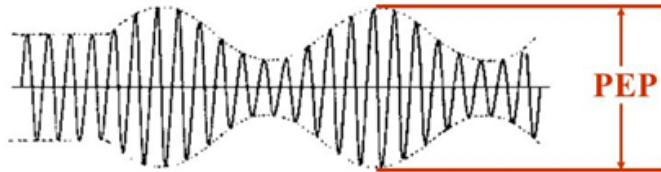

Figure 20. RF peak envelope power

Special needs?

Besides choosing the right frequency range, dynamic range, peak or average power meter and sensors, there are other measurement requirement considerations, such as measurement speed and other advance power measurement capabilities. Measurement speed can be a crucial requirement in a manufacturing or production environment. There are RF power meters which have high measurement speeds up to 1,500 readings/s or more.

Other advance measurement features such as markers for measurement on an RF pulse (shown in Figure 21) are functions available on certain RF peak power meters. Some RF power meters provide statistical measurements such as the CCDF, and histogram distribution.



Figure 21. Advanced measurement features

Conclusion

RF power measurement is a basic need for the study of RF and microwave theories. RF signals can take many forms, from a single carrier continuous wave (CW) to that of a multi-carrier, QAM that contains a high crest-factor wave shape. Measuring the power levels of these widely-varying signals requires understanding their characteristics, as well as a suitable RF power meter and sensors. Besides measuring RF power levels, these instruments can also be used in electrical or RF labs and help students in learning some of the basics of RF devices and circuits design.

References

Document name	Publication type	Literature number
Fundamentals of RF and Microwave Power Measurements (Part 1) (AN 1449)	Application note	5988-9213EN
Fundamentals of RF and Microwave Power Measurements (Part 2) (AN 1449)	Application note	5988-9214EN
Fundamentals of RF and Microwave Power Measurements (Part 3) (AN 1449)	Application note	5988-9215EN
Fundamentals of RF and Microwave Power Measurements (Part 4) (AN 1449)	Application note	5988-9216EN
Keysight Technologies Power Meters and Power Sensors	Brochure	5989-6240EN
Scalar Network Analysis with U2000 Series USB Power Sensors	Application note	5990-7540EN

SNA software available from Keysight Technologies, Inc. at:
http://www.keysight.com/main/software.jsp?cc=MY&lc=eng&ckey=sw322&nid=-35560.695944.02&id=sw322&cmpid=zzfindsnassoftware_download

Evolving Since 1939

Our unique combination of hardware, software, services, and people can help you reach your next breakthrough. We are unlocking the future of technology.

From Hewlett-Packard to Agilent to Keysight.

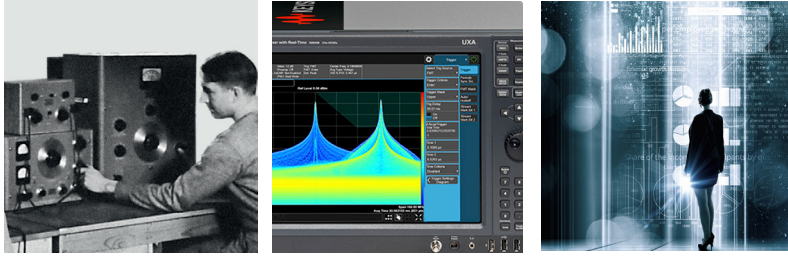

For more information on Keysight Technologies' products, applications or services, please contact your local Keysight office. The complete list is available at:

www.keysight.com/find/contactus

Americas

Canada	(877) 894 4414
Brazil	55 11 3351 7010
Mexico	001 800 254 2440
United States	(800) 829 4444

Asia Pacific

Australia	1 800 629 485
China	800 810 0189
Hong Kong	800 938 693
India	1 800 11 2626
Japan	0120 (421) 345
Korea	080 769 0800
Malaysia	1 800 888 848
Singapore	1 800 375 8100
Taiwan	0800 047 866
Other AP Countries	(65) 6375 8100

Europe & Middle East

Austria	0800 001122
Belgium	0800 58580
Finland	0800 523252
France	0805 980333
Germany	0800 6270999
Ireland	1800 832700
Israel	1 809 343051
Italy	800 599100
Luxembourg	+32 800 58580
Netherlands	0800 0233200
Russia	8800 5009286
Spain	800 000154
Sweden	0200 882255
Switzerland	0800 805353
	Opt. 1 (DE)
	Opt. 2 (FR)
	Opt. 3 (IT)
United Kingdom	0800 0260637

For other unlisted countries:

www.keysight.com/find/contactus
(BP-9-7-17)

DEKRA Certified
ISO 9001 Quality Management System

www.keysight.com/go/quality
Keysight Technologies, Inc.
DEKRA Certified ISO 9001:2015
Quality Management System

myKeysight

myKeysight

www.keysight.com/find/mykeysight

A personalized view into the information most relevant to you.

http://www.keysight.com/find/emt_product_registration

Register your products to get up-to-date product information and find warranty information.

KEYSIGHT SERVICES

Accelerate Technology Adoption.
Lower costs.

Keysight Services

www.keysight.com/find/service

Keysight Services can help from acquisition to renewal across your instrument's lifecycle. Our comprehensive service offerings—one-stop calibration, repair, asset management, technology refresh, consulting, training and more—helps you improve product quality and lower costs.



Keysight Assurance Plans

www.keysight.com/find/AssurancePlans

Up to ten years of protection and no budgetary surprises to ensure your instruments are operating to specification, so you can rely on accurate measurements.

Keysight Channel Partners

www.keysight.com/find/channelpartners

Get the best of both worlds: Keysight's measurement expertise and product breadth, combined with channel partner convenience.

Bluetooth and the Bluetooth logos are trademarks owned by Bluetooth SIG, Inc., U.S.A. and licensed to Keysight Technologies, Inc.

www.keysight.com/find/education



Unlocking Measurement Insights

This information is subject to change without notice.
© Keysight Technologies, 2017
Published in USA, December 1, 2017
5992-1683EN
www.keysight.com