

**MS2830A
Signal Analyzer
Operation Manual
Mainframe
Operation**

19th Edition



**For safety and warning information, please read this manual before attempting to use the equipment.
Keep this manual with the equipment.**

ANRITSU CORPORATION

Safety Symbols







To prevent the risk of personal injury or loss related to equipment malfunction, Anritsu Corporation uses the following safety symbols to indicate safety-related information. Ensure that you clearly understand the meanings of the symbols BEFORE using the equipment. Some or all of the following symbols may be used on all Anritsu equipment. In addition, there may be other labels attached to products that are not shown in the diagrams in this manual.

Symbols used in manual

-  **DANGER** This indicates a very dangerous procedure that could result in serious injury or death if not performed properly.
-  **WARNING** This indicates a hazardous procedure that could result in serious injury or death if not performed properly.
-  **CAUTION** This indicates a hazardous procedure or danger that could result in light-to-severe injury, or loss related to equipment malfunction, if proper precautions are not taken.

Safety Symbols Used on Equipment and in Manual

The following safety symbols are used inside or on the equipment near operation locations to provide information about safety items and operation precautions. Ensure that you clearly understand the meanings of the symbols and take the necessary precautions BEFORE using the equipment.

-  This indicates a prohibited operation. The prohibited operation is indicated symbolically in or near the barred circle.
-  This indicates an obligatory safety precaution. The obligatory operation is indicated symbolically in or near the circle.
-  This indicates a warning or caution. The contents are indicated symbolically in or near the triangle.
-  This indicates a note. The contents are described in the box.
-   These indicate that the marked part should be recycled.

MS2830A
Signal Analyzer
Operation Manual Mainframe Operation

15 December 2009 (First Edition)
26 July 2013 (19th Edition)

Copyright © 2009-2013, ANRITSU CORPORATION.

All rights reserved. No part of this manual may be reproduced without the prior written permission of the publisher.

The contents of this manual may be changed without prior notice.

Printed in Japan

For Safety

WARNING



- ALWAYS refer to the operation manual when working near locations at which the alert mark shown on the left is attached. If the advice in the operation manual is not followed there is a risk of personal injury or reduced equipment performance. The alert mark shown on the left may also be used with other marks and descriptions to indicate other dangers.

- **Overvoltage Category**

This equipment complies with overvoltage category II defined in IEC 61010. DO NOT connect this equipment to the power supply of overvoltage category III or IV.

Electric Shock

- To ensure that the equipment is grounded, always use the supplied 3-pin power cord, and insert the plug into an outlet with a ground terminal. If power is supplied without grounding the equipment, there is a risk of receiving a severe or fatal electric shock or causing damage to the internal components.

Repair

WARNING 

- Only qualified service personnel with a knowledge of electrical fire and shock hazards should service this equipment. This equipment cannot be repaired by the operator. DO NOT attempt to remove the equipment covers or unit covers or to disassemble internal components. There are high-voltage parts in this equipment presenting a risk of severe injury or fatal electric shock to untrained personnel. In addition, there is a risk of damage to precision components.

Calibration



- The performance-guarantee seal verifies the integrity of the equipment. To ensure the continued integrity of the equipment, only Anritsu service personnel, or service personnel of an Anritsu sales representative, should break this seal to repair or calibrate the equipment. Be careful not to break the seal by opening the equipment or unit covers. If the performance-guarantee seal is broken by you or a third party, the performance of the equipment cannot be guaranteed.

For Safety

WARNING

Falling Over

- This equipment should always be positioned in the correct manner. If the cabinet is turned on its side, etc., it will be unstable and may be damaged if it falls over as a result of receiving a slight mechanical shock.

Always set up the equipment in a position where the power switch can be reached without difficulty.

Replacing Battery



- When replacing the battery, use the specified battery and insert it with the correct polarity. If the wrong battery is used, or if the battery is inserted with reversed polarity, there is a risk of explosion causing severe injury or death.

Battery Fluid

- DO NOT short the battery terminals and never attempt to disassemble the battery or dispose of it in a fire. If the battery is damaged by any of these actions, the battery fluid may leak. This fluid is poisonous. DO NOT touch the battery fluid, ingest it, or get in your eyes. If it is accidentally ingested, spit it out immediately, rinse your mouth with water and seek medical help. If it enters your eyes accidentally, do not rub your eyes, rinse them with clean running water and seek medical help. If the liquid gets on your skin or clothes, wash it off carefully and thoroughly.

Battery Disposal

- DO NOT expose batteries to heat or fire. Do not expose batteries to fire. This is dangerous and can result in explosions or fire. Heating batteries may cause them to leak or explode.

LCD

- This equipment uses a Liquid Crystal Display (LCD). DO NOT subject the equipment to excessive force or drop it. If the LCD is subjected to strong mechanical shock, it may break and liquid may leak. This liquid is very caustic and poisonous. DO NOT touch it, ingest it, or get in your eyes. If it is ingested accidentally, spit it out immediately, rinse your mouth with water and seek medical help. If it enters your eyes accidentally, do not rub your eyes, rinse them with clean running water and seek medical help. If the liquid gets on your skin or clothes, wash it off carefully and thoroughly.
-

For Safety

CAUTION

Cleaning

- Always remove the main power cable from the power outlet before cleaning dust around the power supply and fan.
 - Clean the power inlet regularly. If dust accumulates around the power pins, there is a risk of fire.
 - Keep the cooling fan clean so that the ventilation holes are not obstructed. If the ventilation is obstructed, the cabinet may overheat and catch fire.

Check Terminal



- Never input a signal of more than the indicated value between the measured terminal and ground. Input of an excessive signal may damage the equipment.
-

For Safety

CAUTION

Replacing Memory Back-up Battery

This equipment uses a Poly-carbomonofluoride lithium battery to backup the memory. This battery must be replaced by service personnel when it has reached the end of its useful life; contact the Anritsu sales section or your nearest representative.

Note: The battery used in this equipment has a maximum useful life of 7 years. It should be replaced before this period has elapsed.

External Storage Media

This equipment uses USB memory as external storage media for storing data and programs.

If this media is mishandled or becomes faulty, important data may be lost. To prevent this chance occurrence, all important data and programs should be backed-up.

Anritsu will not be held responsible for lost data.

Pay careful attention to the following points.

- Never remove the USB memory from the equipment while it is being accessed.
- The USB memory may be damaged by static electric charges.
- Anritsu has thoroughly tested all external storage media shipped with this equipment. Users should note that external storage media not shipped with this equipment may not have been tested by Anritsu, thus Anritsu cannot guarantee the performance or suitability of such media.

For Safety

CAUTION

Hard disk

The equipment is equipped with an internal hard disk from which, as with any hard disk, data may be lost under certain conditions. To prevent this chance occurrence, all important data and programs should be backed-up.

Anritsu will not be held responsible for lost data.

To reduce the possibility of data loss, particular attention should be given to the following points.

- The equipment should only be used within the recommend temperature range, and should not be used in locations where the temperature may fluctuate suddenly.
- Always follow the guidelines to ensure that the equipment is set up in the specified manner.
- Always ensure that the fans at the rear and side of the equipment are not blocked or obstructed in any way.
- Exercise care not to bang or shake the equipment whilst the power is on.
- Never disconnect the mains power at the plug or cut the power at the breaker with the equipment turned on.

Use in a residential environment

This equipment is designed for an industrial environment. In a residential environment this equipment may cause radio interference in which case the user may be required to take adequate measures.

Use in Corrosive Atmospheres

Exposure to corrosive gases such as hydrogen sulfide, sulfurous acid, and hydrogen chloride will cause faults and failures. Note that some organic solvents release corrosive gases.

Equipment Certificate

Anritsu Corporation certifies that this equipment was tested before shipment using calibrated measuring instruments with direct traceability to public testing organizations recognized by national research laboratories, including the National Institute of Advanced Industrial Science and Technology, and the National Institute of Information and Communications Technology, and was found to meet the published specifications.

Anritsu Warranty

Anritsu Corporation will repair this equipment free-of-charge if a malfunction occurs within one year after shipment due to a manufacturing fault. However, software fixes will be made in accordance with the separate Software End-User License Agreement. Moreover, Anritsu Corporation will deem this warranty void when:

- The fault is outside the scope of the warranty conditions separately described in the operation manual.
- The fault is due to mishandling, misuse, or unauthorized modification or repair of the equipment by the customer.
- The fault is due to severe usage clearly exceeding normal usage.
- The fault is due to improper or insufficient maintenance by the customer.
- The fault is due to natural disaster, including fire, wind, flooding, earthquake, lightning strike, or volcanic ash, etc.
- The fault is due to damage caused by acts of destruction, including civil disturbance, riot, or war, etc.
- The fault is due to explosion, accident, or breakdown of any other machinery, facility, or plant, etc.
- The fault is due to use of non-specified peripheral or applied equipment or parts, or consumables, etc.
- The fault is due to use of a non-specified power supply or in a non-specified installation location.
- The fault is due to use in unusual environments^(Note).
- The fault is due to activities or ingress of living organisms, such as insects, spiders, fungus, pollen, or seeds.

In addition, this warranty is valid only for the original equipment purchaser. It is not transferable if the equipment is resold.

Anritsu Corporation shall assume no liability for injury or financial loss of the customer due to the use of or a failure to be able to use this equipment.

Note:

For the purpose of this Warranty, "unusual environments" means use:

- In places of direct sunlight
- In dusty places
- Outdoors
- In liquids, such as water, oil, or organic solvents, and medical fluids, or places where these liquids may adhere
- In salty air or in place chemically active gases (sulfur dioxide, hydrogen sulfide, chlorine, ammonia, nitrogen oxide, or hydrogen chloride etc.) are present
- In places where high-intensity static electric charges or electromagnetic fields are present
- In places where abnormal power voltages (high or low) or instantaneous power failures occur
- In places where condensation occurs
- In the presence of lubricating oil mists
- In places at an altitude of more than 2,000 m
- In the presence of frequent vibration or mechanical shock, such as in cars, ships, or airplanes

Anritsu Corporation Contact

In the event that this equipment malfunctions, contact an Anritsu Service and Sales office. Contact information can be found on the last page of the printed version of this manual, and is available in a separate file on the CD version.

Software End-User License Agreement (EULA)

Please read this Software End-User License Agreement (hereafter this EULA) carefully before using (includes executing, copying, registering, etc.) this software (includes programs, databases, scenarios, etc., used to operate, set, etc., Anritsu electronic equipment). By reading this EULA and using this software, you are agreeing to be bound by the terms of its contents and Anritsu Corporation (hereafter Anritsu) hereby grants you the right to use this Software with the Anritsu-specified equipment (hereafter Equipment) for the purposes set out in this EULA.

1. Grant of License and Limitations

1. Regardless of whether this Software was purchased from or provided free-of-charge by Anritsu, you agree not to rent, lease, lend, or otherwise distribute this Software to third parties and further agree not to disassemble, recompile, reverse engineer, modify, or create derivative works of this Software.
2. You may make one copy of this Software for backup purposes only.
3. You are not permitted to reverse engineer this software.
4. This EULA allows you to install one copy of this Software on one piece of Equipment.

2. Disclaimers

To the extent not prohibited by law, in no event shall Anritsu be liable for personal injury, or any incidental, special, indirect or consequential damages whatsoever, including, without limitation, damages for loss of profits, loss of data, business interruption or any other commercial damages or losses, arising out of or related to your use or inability to use this Software.

3. Limitation of Liability

- a. If a fault (bug) is discovered in this Software, preventing operation as described in the operation manual or specifications whether or not the customer uses this software as described in the manual, Anritsu shall at its own discretion, fix the bug, or exchange the software, or suggest a workaround, free-of-charge. However, notwithstanding the above, the following items shall be excluded from repair and warranty.
 - i) If this Software is deemed to be used for purposes not described in the operation manual or specifications.
 - ii) If this Software is used in conjunction with other non-Anritsu-approved software.
 - iii) Recovery of lost or damaged data.
 - iv) If this Software or the Equipment has been modified, repaired, or otherwise altered without Anritsu's prior approval.
 - v) For any other reasons out of Anritsu's direct control and responsibility, such as but not limited to, natural disasters, software virus infections, etc.
- b. Expenses incurred for transport, hotel, daily allowance, etc., for on-site repairs by Anritsu engineers necessitated by the above faults shall be borne by you.
- c. The warranty period for faults listed in article 3a above covered by this EULA shall be either 6 months from the date of purchase of this Software or 30 days after the date of repair, whichever is longer.

4. Export Restrictions

You may not use or otherwise export or re-export directly or indirectly this Software except as authorized by Japanese and United States law. In particular, this software may not be exported or re-exported (a) into any Japanese or US embargoed countries or (b) to anyone on the Japanese or US Treasury Department's list of Specially Designated Nationals or the US Department of Commerce Denied Persons List or Entity List. By using this Software, you warrant that you are not located in any such country or on any such list. You also agree that you will not use this Software for any purposes prohibited by Japanese and US law, including, without limitation, the development, design and manufacture or production of missiles or nuclear, chemical or biological weapons of mass destruction.

5. Termination

Anritsu shall deem this EULA terminated if you violate any conditions described herein. This EULA shall also be terminated if the conditions herein cannot be continued for any good reason, such as violation of copyrights, patents, or other laws and ordinances.

6. Reparations

If Anritsu suffers any loss, financial or otherwise, due to your violation of the terms of this EULA, Anritsu shall have the right to seek proportional damages from you.

7. Responsibility after Termination

Upon termination of this EULA in accordance with item 5, you shall cease all use of this Software immediately and shall as directed by Anritsu either destroy or return this Software and any backup copies, full or partial, to Anritsu.

8. Dispute Resolution

If matters of dispute or items not covered by this EULA arise, they shall be resolved by negotiations in good faith between you and Anritsu.

9. Court of Jurisdiction

This EULA shall be interpreted in accordance with Japanese law and any disputes that cannot be resolved by negotiation described in Article 8 shall be settled by the Japanese courts.

Notes On Export Management

This product and its manuals may require an Export License/Approval by the Government of the product's country of origin for re-export from your country.

Before re-exporting the product or manuals, please contact us to confirm whether they are export-controlled items or not.

When you dispose of export-controlled items, the products/manuals need to be broken/shredded so as not to be unlawfully used for military purpose.

Trademark and Registered Trademark

IQproducer™ is a registered trademark of Anritsu Corporation in the United States and/or other countries.

Lifetime of Parts

The life span of certain parts used in this instrument is determined by the operating time or the power-on time. Due consideration should be given to the life spans of these parts when performing continuous operation over an extended period. These parts must be replaced at the customer's expense even if within the guaranteed period described in Warranty at the beginning of this manual. For details on life span, refer to the corresponding section in this manual.

Example: Display backlight, internal hard disk, removable hard disk, connector for hard disk, cooling fan

Cautions against computer virus infection

- Copying files and data
Only files that have been provided directly from Anritsu or generated using Anritsu equipment should be copied to the instrument.
All other required files should be transferred by means of USB or CompactFlash media after undergoing a thorough virus check.
- Adding software
Do not download or install software that has not been specifically recommended or licensed by Anritsu.
- Network connections
Ensure that the network has sufficient anti-virus security protection in place.

Crossed-out Wheeled Bin Symbol

Equipment marked with the Crossed-out Wheeled Bin Symbol complies with council directive 2002/96/EC (the “WEEE Directive”) in European Union.



For Products placed on the EU market after August 13, 2005, please contact your local Anritsu representative at the end of the product's useful life to arrange disposal in accordance with your initial contract and the local law.

CE Conformity Marking

Anritsu affixes the CE Conformity marking on the following product(s) in accordance with the Council Directive 93/68/EEC to indicate that they conform to the EMC and LVD directive of the European Union (EU).

CE marking



1. Product Model

Model: MS2830A Signal Analyzer

2. Applied Directive

EMC: Directive 2004/108/EC

LVD: Directive 2006/95/EC

3. Applied Standards

- EMC: Emission: EN 61326-1: 2006 (Class A)
Immunity: EN 61326-1: 2006 (Table 2)

	Performance Criteria*
IEC 61000-4-2 (ESD)	B
IEC 61000-4-3 (EMF)	A
IEC 61000-4-4 (Burst)	B
IEC 61000-4-5 (Surge)	B
IEC 61000-4-6 (CRF)	A
IEC 61000-4-8 (RPFMF)	A
IEC 61000-4-11 (V dip/short)	B, C

*: Performance Criteria

- A: During testing normal performance within the specification limits.
- B: During testing temporary degradation, or loss of function or performance which is self-recovering.
- C: During testing, temporary degradation, or loss of function or performance which requires operator intervention or system reset occurs.

Harmonic current emissions:

EN 61000-3-2: 2006 +A1:2009 A2:2009

(Class A equipment)

- LVD: EN 61010-1: 2010 (Pollution Degree 2)

4. Authorized representative

Name: Murray Coleman
Head of Customer Service EMEA
ANRITSU EMEA Ltd.

Address, city: 200 Capability Green, Luton
Bedfordshire, LU1 3LU

Country: United Kingdom

C-Tick Conformity Marking

Anritsu affixes the C-Tick marking on the following product(s) in accordance with the regulation to indicate that they conform to the EMC framework of Australia/New Zealand.

C-Tick marking



1. Product Model

Model: MS2830A Signal Analyzer

2. Applied Standards

EMC:Emission: EN 61326-1: 2006 (Class A equipment)

About Eco label



The label shown on the left is attached to Anritsu products meeting our environmental standards.

Details about this label and the environmental standards are available on the Anritsu website at <http://www.anritsu.com>

About This Manual

■ Associated Documents

The operation manual configuration of the MS2830A Signal Analyzer is shown below.

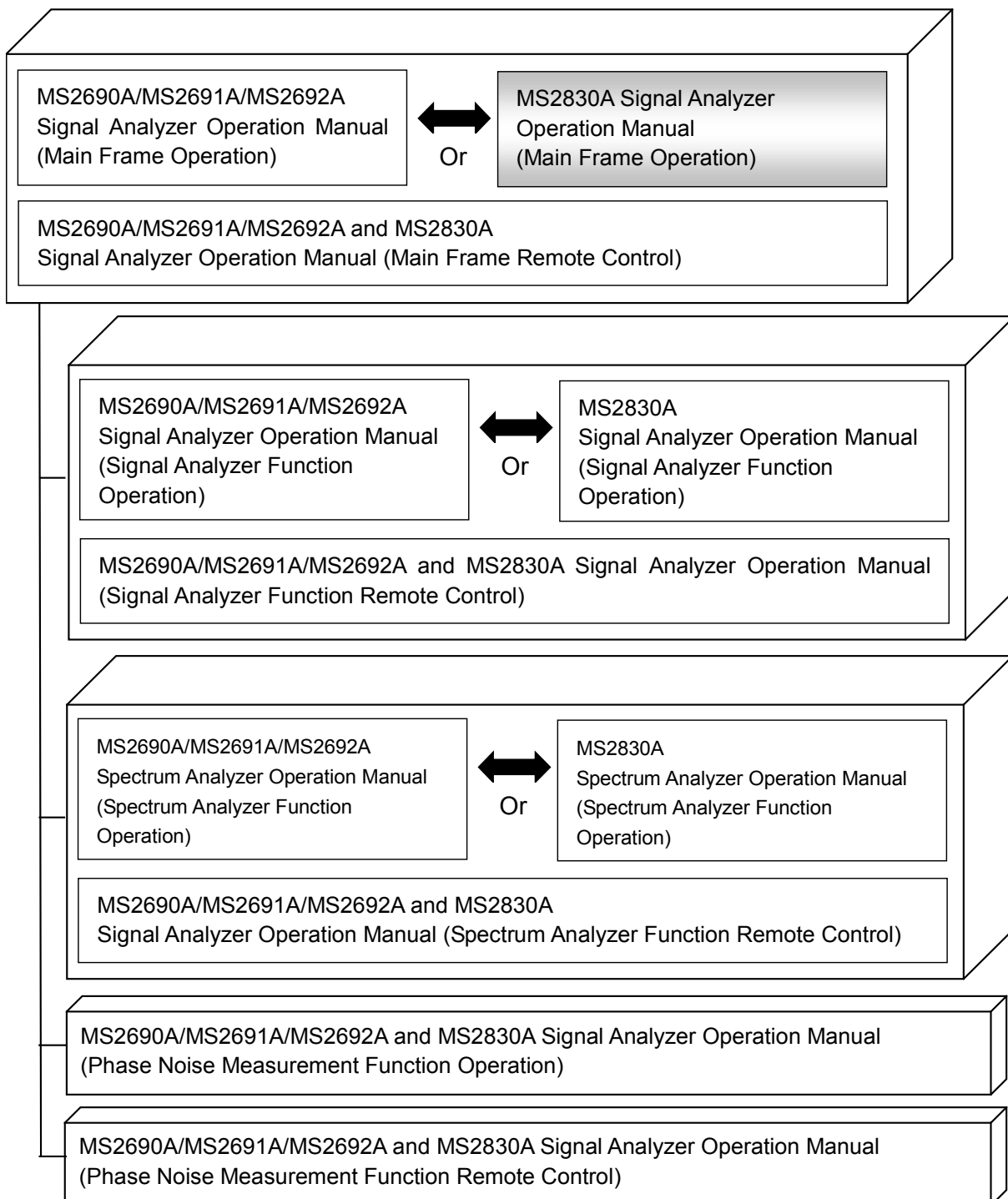

- Signal Analyzer Operation Manual (Mainframe) <This document>
- Signal Analyzer Operation Manual (Mainframe Remote Control)
Description of basic operations, maintenance procedures, common functions and common remote functions of the mainframe
- Signal Analyzer Operation Manual (Signal Analyzer Function)
- Signal Analyzer Operation Manual (Signal Analyzer Function Remote Control)
Description of basic operations, functions and remote functions of the signal analyzer
- Signal Analyzer Operation Manual (Spectrum Analyzer Function)
- Signal Analyzer Operation Manual (Spectrum Analyzer Function Remote Control)
Description of basic operations, functions and remote functions of the spectrum analyzer
- Signal Analyzer Operation Manual (Phase Noise Measurement Function)
- Signal Analyzer Operation Manual (Phase Noise Measurement Function Remote Control)
Description of basic operations, common functions and common remote functions of the Phase Noise Measurement function

In this document,  indicates a panel key.

Table of Contents

For Safety	iii
About This Manual.....	I
Chapter 1 Overview.....	1-1
1.1 Product Overview	1-2
1.2 Product Configuration	1-3
1.3 Specifications.....	1-10
Chapter 2 Before Use.....	2-1
2.1 Installation Location	2-2
2.2 Items to Check Before Use.....	2-4
2.3 Power Connection	2-9
Chapter 3 Common Operations	3-1
3.1 Part Names	3-2
3.2 Turning Power On/Off.....	3-11
3.3 Auto Calibration	3-13
3.4 Settings on Configuration Screen	3-16
3.5 Loading, Unloading, and Switching Applications.....	3-30
3.6 Save and Recall Functions	3-39
3.7 Initializing	3-48
3.8 Installing and Uninstalling.....	3-50
Chapter 4 Tutorial	4-1
4.1 Spectrum Analysis Using Signal Analyzer.....	4-2
4.2 Spectrum Analysis Using Spectrum Analyzer	4-6
Chapter 5 System.....	5-1
5.1 Setting Windows	5-2
5.2 Storage Device Configuration.....	5-10
5.3 System Recovery Functions.....	5-11

1
2
3
4
5
6
7
8
9
Appendix
Index

Chapter 6 Performance Test 6-1

- 6.1 Overview of Performance Test 6-2
- 6.2 Performance Test Items 6-5

Chapter 7 Power Meter 7-1

- 7.1 Power Meter..... 7-2
- 7.2 Display Description 7-3
- 7.3 Function Menu 7-5
- 7.4 Initialization 7-14

Chapter 8 BER Measurement Function.... 8-1

- 8.1 Outline of BER Measurement 8-2
- 8.2 Display Description 8-5
- 8.3 BER Measurement Function Menu..... 8-9
- 8.4 Connecting MS2830A-026/126 to External System .. 8-11
- 8.5 Performing BER Measurement..... 8-12
- 8.6 Setting Automatic Resynchronization Function 8-22
- 8.7 Setting Input Interface..... 8-27
- 8.8 Setting PN_Fix Pattern 8-28
- 8.9 Setting User-defined Pattern 8-34
- 8.10 Description of BER Measurement Operation 8-42

Chapter 9 Maintenance 9-1

- 9.1 Daily Maintenance and Storage..... 9-2
- 9.2 Repackaging and transporting when returning product 9-5
- 9.3 Calibration..... 9-6

Appendix A Performance Test Result Form	A-1
Appendix B Panel Keys and Keyboard Operations.....	B-1
Appendix C Virus Check Procedure	C-1
Appendix D Error Messages	D-1
Appendix E Initial Value List	E-1
Index	Index-1

1
2
3
4
5
6
7
8
9
Appendix
Index

Chapter 1 Overview

This chapter provides an overview of the MS2830A Signal Analyzer and product configuration.

1.1	Product Overview	1-2
1.2	Product Configuration	1-3
1.2.1	Standard configuration	1-3
1.2.2	Options	1-4
1.2.3	Applicable Parts.....	1-7
1.2.4	Application Software.....	1-9
1.3	Specifications.....	1-10
1.3.1	Mainframe (MS2830A)	1-10
1.3.2	Rubidium Reference Oscillator Option (MS2830A-001/101)	1-53
1.3.3	High Stability Reference Oscillator Option (MS2830A-002/102)	1-53
1.3.4	Preamplifier Option (MS2830A-008/108)	1-54
1.3.5	Analysis Bandwidth Extension to 31.25 MHz Option (MS2830A-005/105)	1-55
1.3.6	Analysis Bandwidth Extension to 10 MHz Option (MS2830A-006/106)	1-55
1.3.7	Phase Noise Measurement Option (MS2830A-010/110)	1-55
1.3.8	Secondary HDD Option (MS2830A-011/111)	1-55
1.3.9	Precompliance EMI Function (MS2830A-016/116)	1-55
1.3.10	Low Phase Noise Performance Option (MS2830A-062/066)	1-56
1.3.11	Removable HDD option (MS2830A-313)	1-57
1.3.12	Microwave Preamplifier Option (MS2830A-068/168)	1-58
1.3.13	Microwave Preselector Bypass Option (MS2830A-067/167)	1-59
1.3.14	Bandwidth Extension to 31.25 MHz with Preselector Bypass Option (MS2830A-007) ..	1-61
1.3.15	Analysis Bandwidth Extension Option, 62.5 MHz (MS2830A-077/177)	1-62
1.3.16	Analysis Bandwidth Extension Option, 125 MHz (MS2830A-078/178)	1-63
1.3.17	Bandwidth Extension to 31.25MHz for Millimeter-wave (MS2830A-009/109)	1-63
1.3.18	BER Measurement function (MS2830A-026/126)	1-64

1.1 Product Overview

The MS2830A Signal Analyzer ("the MS2830A" hereafter) is a spectrum analyzer to which options such as real-time signal analysis and vector modulation analysis can be added.

The MS2830A enables high-speed and high-accuracy signal processing of wide-ranging analyses at full-span, a characteristic of conventional sweep-type spectrum analyzers, using a digital IF block. In addition, the FFT process (high-speed Fourier conversion) realizes high-speed spectrum analysis and simultaneous analysis on frequency and time axes not possible with conventional sweep-type spectrum analyzers. Also, added option enables recording of the RF input signal as digital data (digitize function). It can be used in a variety of applications from research and development to manufacturing thanks to its characteristics.

The key features are listed below:

- Wide frequency band (3.6 GHz/6 GHz/13.5 GHz/26.5 GHz/43 GHz)
- Wide analysis bandwidth (Option 006/106: 10 MHz, Option 005/105/007: 31.25 MHz, Option 077/177: 62.5 MHz, Option 078/178: 125 MHz,)
- High dynamic range
- High-speed measurement
- High-speed, high-accuracy signal analysis using digital IF
- Enables time-continuous analysis of loaded data
- Large-capacity waveform memory and digitization function that records RF signals without missing (when option 006/106, 005/105, 007, 077/177, or 078/178 is used)
- BER Measurement function (when option 026/126 is used)
- Rich measurement functions

The MS2830A is equipped with the hardware product made by National Instruments and comes with the license for NI-VISA. NI-VISA can be used for the purpose of controlling the MS2830A.

1.2 Product Configuration

1.2.1 Standard configuration

Table 1.2.1-1 lists the standard configuration. At unpacking, check that all items are included. Contact your Anritsu Service and Sales Office or agent if any parts are missing or damaged.

Table 1.2.1-1 Standard Configuration

Items	Model	Product name	Quantity	Remarks
Unit	MS2830A	Signal Analyzer	1	-
Accessories	J0017F	Power cord	1	
	P0031A	USB memory	1	256MB or more USB 2.0 Flash Driver
	Z0541A	USB Mouse	1	-
	-	Installation CD-ROM	1	Application software, Operation Manual CD-ROM

1.2.2 Options

Tables 1.2.2-1 through 1.2.2-2 list the options. They are sold separately.

Note:

There is a risk of losing the data when adding additional option(s), so **back up the data** stored on the hard disk, in advance. Anritsu is not responsible for any loss of data.

Table 1.2.2-1 Additional Options at/after shipment

Option Number	Product Name	Remarks
MS2830A-040	3.6 GHz Signal Analyzer	9 kHz to 3.6 GHz
MS2830A-041	6 GHz Signal Analyzer	9 kHz to 6 GHz
MS2830A-043	13.5 GHz Signal Analyzer	9 kHz to 13.5 GHz
MS2830A-044	26.5 GHz Signal Analyzer	9 kHz to 26.5 GHz
MS2830A-045	43 GHz Signal Analyzer	9 kHz to 43 GHz
MS2830A-001	Rubidium Reference Oscillator	See Table 1.3.1-1 “Internal reference oscillator”.
MS2830A-101	Rubidium Reference Oscillator Retrofit	See Table 1.3.1-1 “Internal reference oscillator”.
MS2830A-002	High Stability Reference Oscillator	See Table 1.3.1-1, “Internal reference oscillator”
MS2830A-102	High Stability Reference Oscillator, Retrofit	See Table 1.3.1-1, “Internal reference oscillator”
MS2830A-006	Analysis Bandwidth 10 MHz	Analysis bandwidth: Max. 10 MHz
MS2830A-106	Analysis Bandwidth 10 MHz, Retrofit	Analysis bandwidth: Max. 10 MHz
MS2830A-005	Analysis Bandwidth Extension to 31.25 MHz	Extends Analysis Bandwidth to 31.25 MHz
MS2830A-105	Analysis Bandwidth Extension to 31.25 MHz, Retrofit	Extends Analysis Bandwidth to 31.25 MHz
MS2830A-007	Bandwidth Extension to 31.25 MHz with Preselector Bypass	Available only when MS2830A-045 is installed.
MS2830A-009	Bandwidth Extension to 31.25 MHz for Millimeter-wave	Extends Analysis Bandwidth to 31.25 MHz Available only when MS2830A-045 is installed.
MS2830A-109	Bandwidth Extension to 31.25 MHz for Millimeter-wave, Retrofit	Extends Analysis Bandwidth to 31.25 MHz Available only when MS2830A-045 is installed.
MS2830A-077	Analysis Bandwidth Extension to 62.5 MHz	Extends Analysis Bandwidth to 62.5 MHz
MS2830A-177	Analysis Bandwidth Extension to 62.5 MHz, Retrofit	Extends Analysis Bandwidth to 62.5 MHz
MS2830A-078	Analysis Bandwidth Extension to 125 MHz	Extends Analysis Bandwidth to 125 MHz
MS2830A-178	Analysis Bandwidth Extension to 125 MHz, Retrofit	Extends Analysis Bandwidth to 125 MHz

Table 1.2.2-1 Additional Options at/after shipment (Continued)

Option Number	Product Name	Remarks
MS2830A-008	Preamplifier	100 kHz to 3.6 GHz (With MS2830-040) 100 kHz to 6 GHz (With MS2830-041/043)
MS2830A-108	Preamplifier, Retrofit	100 kHz to 3.6 GHz (With MS2830-040) 100 kHz to 6 GHz (With MS2830-041/043)
MS2830A-010	Phase Noise Measurement Function	10 MHz to Upper frequency limit
MS2830A-110	Phase Noise Measurement Function, Retrofit	10 MHz to Upper frequency limit
MS2830A-011	Secondary HDD	
MS2830A-111	Secondary HDD, Retrofit	
MS2830A-016	Precompliance EMI Function	
MS2830A-116	Precompliance EMI Function Retrofit	
MS2830A-017	Noise Figure Measurement Function	
MS2830A-117	Noise Figure Measurement Function Retrofit	
MS2830A-020	3.6 GHz Vector Signal Generator	250 kHz to 3.6 GHz
MS2830A-120	3.6 GHz Vector Signal Generator, Retrofit	250 kHz to 3.6 GHz
MS2830A-021	6 GHz Vector Signal Generator	250 kHz to 6 GHz
MS2830A-121	6 GHz Vector Signal Generator, Retrofit	250 kHz to 6 GHz
MS2830A-022	Low Power Extension for Vector Signal Generator	Lower setting limit of output signal level: -136 dBm
MS2830A-122	Low Power Extension for Vector Signal Generator, Retrofit	Lower setting limit of output signal level: -136 dBm
MS2830A-026	BER Measurement function	
MS2830A-126	BER Measurement function, Retrofit	
MS2830A-027	ARB Memory Upgrade 256 MSample for Vector Signal Generator	
MS2830A-127	ARB Memory Upgrade 256 MSample for Vector Signal Generator, Retrofit	
MS2830A-028	AWGN	
MS2830A-128	AWGN, Retrofit	

Table 1.2.2-1 Additional Options at/after shipment (Continued)

Option Number	Product Name	Remarks
MS2830A-062	Low Phase Noise Performance	
MS2830A-066	Low Phase Noise Performance	
MS2830A-067	Microwave Preselector Bypass	With MS2830A-044/045 installed
MS2830A-167	Microwave Preselector Bypass, Retrofit	With MS2830A-044/045 installed
MS2830A-068	Microwave Preamplifier	100 kHz to 26.5 GHz (With MS2830A-044 installed) 100 kHz to 43 GHz (With MS2830-045 installed)
MS2830A-168	Microwave Preamplifier, Retrofit	100 kHz to 26.5 GHz (With MS2830A-044 installed) 100 kHz to 43 GHz (With MS2830-045 installed)
MS2830A-313	Removable HDD	

Table 1.2.2-2 Optional Warranty Extension (MS2830A)

Option Number	Product Name	Remarks
MS2830A-ES210	2-year Warranty Service	-
MS2830A-ES310	3-year Warranty Service	-
MS2830A-ES510	5-year Warranty Service	-

1.2.3 Applicable Parts

Table 1.2.3-1 lists the application parts. They are sold separately.

Table 1.2.3-1 Applicable Parts

Model Number	Product Name	Remarks
W3334AE	MS2830A Signal Analyzer Operation Manual (Mainframe Operation)	Printed version
W2851AE	MS2690A/MS2691A/MS2692A and MS2830A Signal Analyzer Operation Manual (Mainframe Remote Control)	Printed version
W3335AE	MS2830A Signal Analyzer Operation Manual (Signal Analyzer Function Operation)	Printed version
W2853AE	MS2690A/MS2691A/MS2692A and MS2830A Signal Analyzer Operation Manual (Signal Analyzer Function Remote Control)	Printed version
W3336AE	MS2830A Signal Analyzer Operation Manual (Spectrum Analyzer Function Operation)	Printed version
W2855AE	MS2690A/MS2691A/MS2692A and MS2830A Signal Analyzer Operation Manual (Spectrum Analyzer Function Remote Control)	Printed version
W3117AE	MS2690A/MS2691A/MS2692A and MS2830A Signal Analyzer Operation Manual (Phase Noise Measurement Function Operation)	Printed version
W3118AE	MS2690A/MS2691A/MS2692A and MS2830A Signal Analyzer Operation Manual (Phase Noise Measurement Function Remote Control)	Printed version
W3337AE	MS2830A Signal Analyzer Vector Signal Generator Operation Manual (Operation)	Printed version
W3338AE	MS2830A Signal Analyzer Vector Signal Generator Operation Manual (Remote Control)	Printed version
W2914AE	MS2690A/MS2691A/MS2692A and MS2830A Signal Analyzer Vector Signal Generator Operation Manual (IQproducer™)	Printed version
W2929AE	MS2690A/MS2691A/MS2692A and MS2830A Signal Analyzer Vector Signal Generator Operation Manual (Standard Waveform Pattern)	Printed version

Table 1.2.3-1 Applicable Parts (Continued)

Model Number	Product Name	Remarks
K240B	Power divider (K connector)	DC to 26.5 GHz, 50 Ω K-J, 1W _{max}
MA1612A	FOUR-PORT Junction PAD	5 MHz to 3 GHz, N-J
MP752A	TERMINATION	DC to 12.4 GHz, 50 Ω N-P
MA24106A	USB Power Sensor	50 MHz to 6 GHz, with USB/Mini B cable (Refer to Appendix D)
J0576B	Coaxial Cord	Approx. 1 m length (N-P, 5D-2W, N-P)
J0576D	Coaxial Cord	Approx. 2 m length (N-P, 5D-2W, N-P)
J0127A	Coaxial Cord	Approx. 1 m length (BNC-P, RG58A/U, BNC-P)
J0127B	Coaxial Cord	Approx. 2 m length (BNC-P, RG58A/U, BNC-P)
J0127C	Coaxial Cord	Approx. 0.5 m length (BNC-P, RG58A/U, BNC-P)
J0322A	Coaxial Cord	DC to 18 GHz, approx 0.5 m length (SMA-P, 50 Ω SUCOFLEX104, SMA-P)
J0322B	Coaxial Cord	DC to 18 GHz, approx 1 m length (SMA-P, 50 Ω SUCOFLEX104, SMA-P)
J0322C	Coaxial Cord	DC to 18 GHz, approx 1.5 m length (SMA-P, 50 Ω SUCOFLEX104, SMA-P)
J0322D	Coaxial Cord	DC to 18 GHz, approx 2 m length (SMA-P, 50 Ω SUCOFLEX104, SMA-P)
J1398A	N-SMA ADAPTOR	DC to 26.5 GHz, 50 Ω N-P, SMA-J
J0911	Coaxial cord, 1.0 M (for 40 GHz)	DC to 40 GHz, approx 1 m length (SF102A, 11K254/11K254/1.0M)
J0912	Coaxial cord, 0.5 M (for 40 GHz)	DC to 40 GHz, approx 0.5 m length (SF102A, 11K254/11K254/0.5M)
41KC-3	Fixed attenuator, 3 dB	DC to 40 GHz, 3 dB

Table 1.2.3-1 Applicable Parts (Continued)

Model Number	Product Name	Remarks
J1261A	Ethernet cable (shield type)	Straight cable, 1 m
J1261B	Ethernet cable (shield type)	Straight cable, 3 m
J1261C	Ethernet cable (shield type)	Crossover cable, 1 m
J1261D	Ethernet cable (shield type)	Crossover cable, 3 m
J0008	GPIB cable, 2.0 m	Approx. 2 m length
J1487A	AUX conversion adapter	AUX → BNC For vector signal generator option
J1556A	AUX conversion adapter	AUX → BNC For vector signal generator option and BER measurement function option
B0635A	Rack Mount Kit	
B0636A	Carrying case	Protective cover, casters
Z0975A	Keyboard (USB)	
34AKNF50	Ruggedized K-To-Type N Female Adapter	DC to 20 GHz, SWR: 1.25

1.2.4 Application Software

For the latest information on the application software, either visit the MS2830A page on the Anritsu web site or contact an Anritsu sales representative.

Application software is sold separately.

Anritsu homepage: <http://www.anritsu.com/>

1.3 Specifications

1.3.1 Mainframe (MS2830A)

Tables 1.3.1-1 through 1.3.1-3 show the specifications.

The following specification values are those under the conditions after 30-min warm-up at stable ambient temperature.

Typical values are only for reference and are not guaranteed.

Nominal values are not guaranteed.

The following conditions should apply (unless otherwise noted):

Auto Sweep Time Select	: Normal
Auto Swp Type Rules	: Swept Only
Switching Speed mode	: Normal (Best Phase Noise)
Attenuator Mode	: Mechanical Atten Only

Table 1.3.1-1 Specifications for Mainframe

Item	Specification		
Frequency			
Frequency range	9 kHz to 3.6 GHz	(MS2830A-040)	
	9 kHz to 6 GHz	(MS2830A-041)	
	9 kHz to 13.5 GHz	(MS2830A-043)	
	9 kHz to 26.5 GHz	(MS2830A-044)	
	9 kHz to 43 GHz	(MS2830A-045)	
Frequency band configuration		Band	Mixer harmonic order [N]
	9 kHz to 4000 MHz	0	1
	3500 MHz to 4400 MHz	1	1/2
	4300 MHz to 6100 MHz	1	1
	5900 MHz to 10575 MHz	2	1
	10425 MHz to 13600 MHz	2	2
	With MS2830A-044/045 installed,		
		Band	Mixer harmonic order [N]
	9 kHz to 4000 MHz	0	1
	3500 MHz to 4400 MHz	1	1/2
	4300 MHz to 6000 MHz	1	1
	3900 MHz to 8000 MHz	3	1
	7900 MHz to 10575 MHz	4	1
	10475 MHz to 12200 MHz	5	2
	12100 MHz to 18400 MHz	6	2
	18300 MHz to 26600 MHz	7	4
	26500 MHz to 41900 MHz	8	4
	41800 MHz to 43000 MHz	9	8
Preselector range	Frequency Band Mode: Normal		
	4 GHz to 6 GHz	(MS2830A-041)	
	Frequency Band Mode: Spurious		
	3.5 GHz to 6 GHz	(MS2830A-041)	
	Frequency Band Mode: Normal		
	4 GHz to 13.5 GHz	(MS2830A-043)	
	Frequency Band Mode: Spurious		
	3.5 GHz to 13.5 GHz	(MS2830A-043)	
	Frequency Band Mode: Normal		
	4 GHz to 26.5 GHz	(MS2830A-044)	
	Frequency Band Mode: Spurious		
	3.5 GHz to 26.5 GHz	(MS2830A-044)	
	Frequency Band Mode: Normal		
	4 GHz to 43 GHz	(MS2830A-045)	
	Frequency Band Mode: Spurious		
	3.5 GHz to 43 GHz	(MS2830A-045)	
Frequency settings			
Settable range	-100 MHz to 3.7 GHz	(MS2830A-040)	
	-100 MHz to 6.1 GHz	(MS2830A-041)	
	-100 MHz to 13.6 GHz	(MS2830A-043)	
	-100 MHz to 26.6 GHz	(MS2830A-044)	
	-100 MHz to 43.1 GHz	(MS2830A-045)	
Resolution	1 Hz		

Table 1.3.1-1 Specifications for Mainframe (Continued)

Item	Specification
Internal reference oscillator	With MS2830A-040/041/043 installed,
	Without MS2830A-001/101/002/102 installed,
Aging rate	±1 × 10 ⁻⁶ /year
Temperature characteristics	±2.5 × 10 ⁻⁶ (5°C to 45°C)
	With MS2830A-002/102 installed,
Activation characteristics	Based on frequency 24 hours after power application, at 23°C
	±5 × 10 ⁻⁷ (2 minutes after power application)
	±5 × 10 ⁻⁸ (5 minutes after power application)
Aging rate	±1 × 10 ⁻⁷ /year
Temperature characteristics	±2 × 10 ⁻⁸ (5°C to 45°C)
	With MS2830A-044/045 installed,
Activation characteristics	Based on frequency 24 hours after power application, at 23°C
	±5 × 10 ⁻⁷ (2 minutes after power application)
	±5 × 10 ⁻⁸ (5 minutes after power application)
Aging rate	±1 × 10 ⁻⁷ /year
Temperature characteristics	±2 × 10 ⁻⁸ (5°C to 45°C)
	With MS2830A-040/041/043/044/045 installed,
	With MS2830A-001/101 installed,
Activation characteristics	Based on frequency 24 hours after power application, at 23°C
	±1 × 10 ⁻⁹ (7 minutes after power application)
Aging rate	±1 × 10 ⁻¹⁰ /month
Temperature characteristics	±1 × 10 ⁻⁹ (5°C to 45°C)

Table 1.3.1-1 Specifications for Mainframe (Continued)

Item	Specification																						
Single side band noise	<p>At 18°C to 28°C, 500 MHz, spectrum analyzer function Switching Speed mode: Normal (Best Phase Noise)</p> <p>(Frequency offset)</p> <table data-bbox="702 555 1149 622"> <tr> <td>100 kHz</td> <td>-115 dBc/Hz</td> </tr> <tr> <td>1 MHz</td> <td>-133 dBc/Hz</td> </tr> </table> <p>With MS2830A-062 installed and operating (062: Enabled, Center frequency: 500 MHz, and SPAN ≤ 1 MHz as spectrum analyzer) at the temperature of 18°C to 28 °C.</p> <p>(Frequency Offset)</p> <table data-bbox="702 779 1260 902"> <tr> <td>1 kHz</td> <td>-107 dBc/Hz</td> </tr> <tr> <td>10 kHz</td> <td>-113 dBc/Hz</td> </tr> <tr> <td>100 kHz</td> <td>-133 dBc/Hz</td> </tr> <tr> <td>1 MHz</td> <td>-148 dBc/Hz Nominal</td> </tr> </table> <p>With MS2830A-066 installed and operating (066: Enabled, Center frequency: 500 MHz, and SPAN ≤ 1 MHz as spectrum analyzer) at the temperature of 18°C to 28 °C.</p> <p>(Frequency Offset)</p> <table data-bbox="702 1052 1260 1176"> <tr> <td>1 kHz</td> <td>-109 dBc/Hz</td> </tr> <tr> <td>10 kHz</td> <td>-118 dBc/Hz</td> </tr> <tr> <td>100 kHz</td> <td>-133 dBc/Hz</td> </tr> <tr> <td>1 MHz</td> <td>-148 dBc/Hz Nominal</td> </tr> </table> <p>With MS2830A-066 installed and operating (066: Enabled, Center frequency: 220 MHz, and SPAN ≤ 500 kHz as spectrum analyzer) at the temperature of 18°C to 28 °C.</p> <p>(Frequency Offset)</p> <table data-bbox="702 1326 1149 1355"> <tr> <td>25 kHz</td> <td>-122 dBc/Hz</td> </tr> </table>	100 kHz	-115 dBc/Hz	1 MHz	-133 dBc/Hz	1 kHz	-107 dBc/Hz	10 kHz	-113 dBc/Hz	100 kHz	-133 dBc/Hz	1 MHz	-148 dBc/Hz Nominal	1 kHz	-109 dBc/Hz	10 kHz	-118 dBc/Hz	100 kHz	-133 dBc/Hz	1 MHz	-148 dBc/Hz Nominal	25 kHz	-122 dBc/Hz
100 kHz	-115 dBc/Hz																						
1 MHz	-133 dBc/Hz																						
1 kHz	-107 dBc/Hz																						
10 kHz	-113 dBc/Hz																						
100 kHz	-133 dBc/Hz																						
1 MHz	-148 dBc/Hz Nominal																						
1 kHz	-109 dBc/Hz																						
10 kHz	-118 dBc/Hz																						
100 kHz	-133 dBc/Hz																						
1 MHz	-148 dBc/Hz Nominal																						
25 kHz	-122 dBc/Hz																						

Table 1.3.1-1 Specifications for Mainframe (Continued)

Item	Specification
Amplitude	
Measurement range	Without MS2830A-008/108/068/168 or with Preamplifier turned off Average noise level up to +30 dBm With MS2830A-008/108/068/168 and Preamplifier turned on Average noise level up to +10 dBm
Maximum input level Continuous wave average power DC Continuous wave average power DC Continuous wave average power DC Continuous wave average power DC	With MS2830A-040/041/043 installed, Without MS2830A-008/108 or with Preamplifier turned off: +30 dBm (Input attenuator ≥ 10 dB) +20 dBm (Input attenuator = 0 dB) ±10 Vdc With MS2830A-008/108 and Preamplifier turned on: +10 dBm (Input attenuator = 0 dB) ±10 Vdc With MS2830A-044/045 installed, Without MS2830A-008/108/068/168 or with Preamplifier turned off: +30 dBm (Input attenuator ≥ 10 dB) +20 dBm (Input attenuator = 0 dB) ±0 Vdc With MS2830A-008/108/068/168 and Preamplifier turned on: +10 dBm (Input attenuator = 0 dB) ±0 Vdc
Input attenuator	With MS2830A-040/041/043/044 installed, 0 to 60 dB, 2 dB steps With MS2830A-045 installed, Attenuator Mode: E-ATT Combined Mode, Stop frequency < 6 GHz 0 to 10 dB, 10 dB steps 10 to 40dB, 2 dB steps 40 to 60 dB, 10 dB steps Attenuator Mode: M-ATT Only or Attenuator Mode: E-ATT Combined Mode, Stop frequency ≥ 6 GHz 0 to 60 dB, 10 dB steps

Table 1.3.1-1 Specifications for Mainframe (Continued)

Item	Specification
Input attenuator switching error	Based on input attenuator 10 dB, at 18°C to 28°C Without MS2830A-008/108/068/168 or with Preamplifier turned off: ±0.2 dB (10 to 60 dB) (300 kHz ≤ frequency < 4 GHz, Frequency Band Mode: Normal) (300 kHz ≤ frequency < 3.5 GHz, Frequency Band Mode: Spurious) ±0.75 dB (10 to 60 dB) (4 GHz ≤ frequency ≤ 13.8 GHz, Frequency Band Mode: Normal) (3.5 GHz ≤ frequency ≤ 13.8 GHz, Frequency Band Mode: Spurious) ±0.80 dB (10 to 60 dB) (13.8 GHz ≤ frequency ≤ 26.5 GHz) ±1.0 dB (10 to 60 dB) (26.5 GHz ≤ frequency ≤ 40 GHz) ±1.0 dB typ.(10 to 60 dB) (40 GHz ≤ frequency ≤ 43 GHz)
Reference level	
Setting range	Log scale: -120 to +50 dBm or equivalent value Linear scale: 22.4 μV to 70.7 V or equivalent value Resolution: 0.01 dB or equivalent level
Unit	Log scale: dBm, dBμV, dBmV, dBμV (emf), dBμV/m, V, W Linear scale: V

Table 1.3.1-1 Specifications for Mainframe (Continued)

Item	Specification
Linearity error	<p>Without MS2830A-008/108/068/168 or with Preamplifier turned off:</p> <p>Excluding the noise floor effect</p> <p style="padding-left: 40px;">±0.07 dB (mixer input level ≤ -20 dBm)</p> <p style="padding-left: 40px;">±0.10 dB (mixer input level ≤ -10 dBm)</p> <p>With MS2830A-008/108 and with Preamplifier turned on:</p> <p>Excluding the noise floor effect</p> <p style="padding-left: 40px;">±0.07 dB (Preamplifier Input Level: ≤ -40 dBm)</p> <p style="padding-left: 40px;">±0.10 dB (Preamplifier Input Level: ≤ -30 dBm)</p> <p>When Attenuator Mode is E-ATT Combined:</p> <p>Without MS2830A-008/108/068/168 and with Preamplifier turned off:</p> <p>Excluding the noise floor effect</p> <p style="padding-left: 40px;">±0.07dB (mixer input level: ≤ -20dBm, RF Input Level: ≤ -10dBm)</p> <p style="padding-left: 40px;">±0.10dB (mixer input level: ≤ -10dBm, RF Input Level: ≤ -10dBm)</p> <p style="padding-left: 40px;">±0.07dB Nominal</p> <p style="padding-left: 80px;">(mixer input level: ≤ -20dBm, 9kHz ≤ Frequency ≤ 300MHz, RF input level ≤ +5dBm)</p> <p style="padding-left: 80px;">(mixer input level: ≤ -20dBm, 300MHz < Frequency ≤ 6GHz, RF input level ≤ +20dBm)</p> <p style="padding-left: 40px;">±0.10dB Nominal</p> <p style="padding-left: 80px;">(mixer input level: ≤ -10dBm, 9kHz ≤ Frequency ≤ 300MHz, RF input level ≤ +5dBm)</p> <p style="padding-left: 80px;">(mixer input level: ≤ -10dBm, 300MHz < Frequency ≤ 6GHz, RF input level ≤ +20dBm)</p>

Table 1.3.1-1 Specifications for Mainframe (Continued)

Item	Specification
RF frequency characteristics	<p>After CAL execution at 18°C to 28°C, input attenuator = 10 dB,</p> <p>With MS2830A-040/041/043, and without MS2830A-008/108, or with Preamplifier turned off:</p> <p>±1.0 dB (9 kHz ≤ frequency < 300 kHz)</p> <p>±0.35 dB (300 kHz ≤ frequency < 4 GHz, Frequency Band Mode: Normal) (300 kHz ≤ frequency < 3.5 GHz, Frequency Band Mode: Spurious)</p> <p>±1.50 dB (4 GHz ≤ frequency ≤ 6 GHz, Frequency Band Mode: Normal) (3.5 GHz ≤ frequency ≤ 6 GHz, Frequency Band Mode: Spurious)</p> <p>±1.50 dB (6 GHz < frequency)</p> <p>With MS2830A-040/041/043, and with MS2830A-008/108, and with Preamplifier turned on:</p> <p>±0.65 dB (300 kHz ≤ frequency < 4 GHz, Frequency Band Mode: Normal) (300 kHz ≤ frequency < 3.5 GHz, Frequency Band Mode: Spurious)</p> <p>±1.8 dB (4 GHz ≤ frequency ≤ 6 GHz, Frequency Band Mode: Normal) (3.5 GHz ≤ frequency ≤ 6 GHz, Frequency Band Mode: Spurious)</p> <p>With MS2830A-044/045, Without MS2830A-008/108/068/168, or with Preamplifier turned off, Without MS2830A-067/167 or with Microwave Preselector Bypass turned off and after Preselector Auto Tune is done:</p> <p>±1.0 dB (9 kHz ≤ frequency < 300 kHz)</p> <p>±0.35 dB (300 kHz ≤ frequency < 4 GHz, Frequency Band Mode: Normal) (300 kHz ≤ frequency < 3.5 GHz, Frequency Band Mode: Spurious)</p> <p>±1.50 dB (4 GHz ≤ frequency ≤ 6 GHz, Frequency Band Mode: Normal) (3.5 GHz ≤ frequency ≤ 6 GHz, Frequency Band Mode: Spurious)</p> <p>±1.50 dB (6 GHz < frequency ≤ 13.8 GHz)</p> <p>±2.50 dB (13.8 GHz < frequency ≤ 26.5 GHz)</p> <p>±2.50 dB (26.5 GHz < frequency ≤ 40 GHz)</p> <p>±2.50 dB typ. (40 GHz < frequency ≤ 43 GHz)</p>

Table 1.3.1-1 Specifications for Mainframe (Continued)

Item	Specification
RF frequency characteristics (Continued)	<p>With MS2830A-044/045, and with MS2830A-008/108, and with Preamplifier turned on:</p> <p>±0.65 dB (300 kHz ≤ frequency < 4 GHz, Frequency Band Mode: Normal) (300 kHz ≤ frequency < 3.5 GHz, Frequency Band Mode: Spurious)</p> <p>±1.8 dB (4 GHz ≤ frequency ≤ 6 GHz, Frequency Band Mode: Normal) (3.5 GHz ≤ frequency ≤ 6 GHz, Frequency Band Mode: Spurious)</p> <p>With MS2830A-044/045, and with MS2830A-068/168, with Preamplifier turned on, Without MS2830A-067/167 or with Microwave Preselector Bypass turned off and after Preselector Auto Tune is done:</p> <p>±0.65 dB (300 kHz ≤ frequency < 4 GHz, Frequency Band Mode: Normal) (300 kHz ≤ frequency < 3.5 GHz, Frequency Band Mode: Spurious)</p> <p>±1.8 dB (4 GHz ≤ frequency ≤ 13.8 GHz, Frequency Band Mode: Normal) (3.5 GHz ≤ frequency ≤ 13.8 GHz, Frequency Band Mode: Spurious)</p> <p>±2.50 dB (13.8 GHz < frequency ≤ 26.5 GHz)</p> <p>±3.50 dB (26.5 GHz < frequency ≤ 40 GHz)</p> <p>±3.50 dB Nominal (40 GHz < frequency ≤ 43 GHz)</p>

Table 1.3.1-1 Specifications for Mainframe (Continued)

Item	Specification
1 dB gain compression	<p>With MS2830A-040/041/043 installed, Without MS2830A-008/108 or with Preamplifier turned off: At mixer input level $\geq +3$ dBm (300 MHz \leq frequency \leq 6 GHz) ≥ -1 dBm (6 GHz < frequency \leq 13.5 GHz) With MS2830A-008/108 and Preamplifier turned on: At Preamplifier input level ≥ -15 dBm (300 MHz \leq frequency \leq 6 GHz)</p> <p>With MS2830A-044/045 installed, Without MS2830A-068/168 or with Preamplifier turned off: At mixer input level $\geq +3$ dBm (300 MHz \leq frequency \leq 4 GHz) ≥ -1 dBm (4 GHz < frequency \leq 13.5 GHz) ≥ -1 dBm (13.5 GHz < frequency \leq 26.5 GHz) ≥ -1 dBm Nominal (26.5 GHz < frequency \leq 40 GHz) With MS2830A-068/168 and Preamplifier turned on: At Preamplifier input level ≥ -15 dBm (300 MHz \leq frequency \leq 4 GHz) ≥ -21 dBm (4 GHz < frequency \leq 13.5 GHz) ≥ -21 dBm (13.5 GHz < frequency \leq 26.5 GHz) ≥ -21 dBm Nominal (26.5 GHz < frequency \leq 40 GHz)</p>

Table 1.3.1-1 Specifications for Mainframe (Continued)

Item	Specification
Spurious response	
Secondary harmonic wave distortion	<p>With MS2830A-040/041/043 installed, Without MS2830A-008/108 or with Preamplifier turned off: At mixer input level = -30 dBm Harmonics [dBc] SHI[dBm] ≤ -60 $\geq +30$ (10 MHz \leq Input frequency \leq 300 MHz) ≤ -65 $\geq +35$ (300 MHz < Input frequency \leq 1 GHz) ≤ -65 $\geq +35$ (1 GHz < Input frequency \leq 2 GHz) At mixer input level = -10 dBm Harmonics [dBc] SHI[dBm] ≤ -70 $\geq +60$ (2 GHz < Input frequency \leq 3 GHz, Frequency Band Mode: Normal) ≤ -70 $\geq +60$ (1.75 GHz \leq Input frequency \leq 3 GHz, Frequency Band Mode: Spurious) At mixer input level = -10 dBm Harmonics [dBc] SHI[dBm] ≤ -70 $\geq +60$ (3 GHz < Input frequency \leq 6.75 GHz)</p> <p>With MS2830A-008/108 and with Preamplifier turned on: At preamplifier input level = -45 dBm Harmonics [dBc] SHI[dBm] ≤ -50 $\geq +5$ (10 MHz \leq frequency \leq 300 MHz) ≤ -55 $\geq +10$ (300 MHz \leq frequency \leq 3 GHz)</p> <p>With MS2830A-044/045 installed, Without MS2830A-008/108/068/168 and MS2830A-067/167: At mixer input level = -30 dBm Harmonics [dBc] SHI[dBm] ≤ -60 $\geq +30$ (10 MHz \leq Input frequency \leq 300 MHz) ≤ -65 $\geq +35$ (300 MHz < Input frequency \leq 1 GHz) ≤ -65 $\geq +35$ (1 GHz < Input frequency \leq 2 GHz, Frequency Band Mode: Normal) ≤ -65 $\geq +35$ (1 GHz < Input frequency \leq 1.75 GHz, Frequency Band Mode: Spurious)</p>

Table 1.3.1-1 Specifications for Mainframe (Continued)

Item	Specification
Secondary harmonic wave distortion (Continued)	<p>At mixer input level = -10 dBm Harmonics [dBc] SHI[dBm] ≤ -70 $\geq +60$ (2 GHz < Input frequency \leq 3 GHz, Frequency Band Mode: Normal) ≤ -70 $\geq +60$ (1.75 GHz \leq Input frequency \leq 3 GHz, Frequency Band Mode: Spurious) ≤ -90 $\geq +80$ (3 GHz < Input frequency \leq 6.75 GHz) ≤ -90 $\geq +80$ (6.75 GHz < Input frequency \leq 13.25 GHz) ≤ -90 $\geq +80$ Nominal (13.25 GHz < Input frequency \leq 21.5 GHz)</p> <p>With MS2830A-044/045 installed, With MS2830A-068/168 and with Preamplifier turned off: Or with MS2830A-067/167 and with Microwave Preselector Bypass turned off: At mixer input level = -30 dBm Harmonics [dBc] SHI[dBm] ≤ -60 $\geq +30$ (10 MHz \leq frequency \leq 300 MHz) ≤ -65 $\geq +35$ (300 MHz < frequency \leq 1 GHz) ≤ -65 $\geq +35$ (1 GHz < frequency \leq 2 GHz, Frequency Band Mode: Normal) ≤ -65 $\geq +35$ (1 GHz < frequency \leq 1.75 GHz, Frequency Band Mode: Spurious)</p> <p>At mixer input level = -10 dBm Harmonics [dBc] SHI[dBm] ≤ -70 $\geq +60$ (2 GHz < Input frequency \leq 3 GHz, Frequency Band Mode: Normal) ≤ -70 $\geq +60$ (1.75 GHz \leq Input frequency \leq 3 GHz, Frequency Band Mode: Spurious) ≤ -70 $\geq +60$ (3 GHz < Input frequency \leq 6.75 GHz) ≤ -70 $\geq +60$ (6.75 GHz < Input frequency \leq 13.25 GHz) ≤ -70 $\geq +60$ Nominal (13.25 GHz < Input frequency \leq 21.5 GHz)</p> <p>Without MS2830A-068/168 or with Preamplifier turned on: (13.25 GHz < Input frequency \leq 21.5 GHz)</p>

Table 1.3.1-1 Specifications for Mainframe (Continued)

Item	Specification
Secondary harmonic wave distortion (Continued)	<p>With MS2830A-044/045 installed, With MS2830A-008/108/068/168 and with Preamplifier turned on: Or with MS2830A-067/167 and with Microwave Preselector Bypass turned off: At mixer input level = -45 dBm Harmonics [dBc] SHI[dBm] ≤-50 ≥+5 (10 MHz≤Input frequency≤300 MHz) ≤-55 ≥+10 (300 MHz<Input frequency≤2 GHz) ≤-45 ≥0 (2 GHz<Input frequency≤6.75 GHz) ≤-45 ≥0 (6.75 GHz<Input frequency≤13.25 GHz) ≤-40 ≥-5 Nominal (13.25 GHz<Input frequency≤21.5 GHz)</p> <p>When Attenuator Mode is E-ATT Combined: Without MS2830A-008/108/068/168 and with Preamplifier turned off: At mixer input level = -30dBm Harmonics [dBc] SHI[dBm] ≤-60 ≥+30 (10MHz≤ Input frequency ≤300MHz, RF input level ≤5dBm) ≤-65 ≥+35 (300MHz<Input frequency ≤1GHz, RF input level ≤5dBm) ≤-65 ≥+35 (1GHz<Input frequency≤2GHz, Frequency Band Mode: Normal, RF input level ≤+5dBm) (1GHz<Input frequency≤1.75GHz, Frequency Band Mode: Spurious, RF input level ≤+5dBm)</p> <p>At mixer input level = -10dBm Harmonics [dBc] SHI[dBm] ≤-70 ≥+60 (2GHz < Input frequency ≤3GHz, Frequency Band Mode: Normal, RF input level ≤+5dBm) (1.75GHz ≤ Input frequency ≤ 3GHz, Frequency Band Mode: Spurious, RF input level ≤+5dBm)</p>

Table 1.3.1-1 Specifications for Mainframe (Continued)

Item	Specification
Secondary harmonic wave distortion (Continued)	<p>At mixer input level = -30dBm Harmonics [dBc] SHI[dBm] ≤-60 ≥+30 Nominal (10MHz ≤ Input frequency ≤300MHz, RF input level ≤0dBm) ≤-65 ≥+35 Nominal (300MHz < Input frequency ≤1GHz, RF input level ≤+15dBm) ≤-65 ≥+35 Nominal (1GHz < Input frequency ≤2GHz, Frequency Band Mode: Normal, RF input level ≤+15dBm) (1GHz < Input frequency ≤1.75GHz, Frequency Band Mode: Spurious, RF input level ≤+15dBm)</p> <p>At mixer input level = -10dBm Harmonics [dBc] SHI[dBm] ≤-70 ≥+60 Nominal (2GHz ≤Input frequency ≤3GHz, Frequency Band Mode: Normal, RF input level ≤+15dBm) (1.75GHz ≤ nput frequency ≤3GHz, Frequency Band Mode: Spurious, RF input level ≤+15dBm) SHI: Second Harmonic Intercept</p>
Residual response	<p>Frequency ≥1 MHz, Input attenuator = 0 dB, at 50 Ω terminator (With MS2830A-077/177/078/178 installed, excluding Bandwidth > 31.25 MHz.)</p> <p>Up to 1 GHz ≤-100 dBm 1 GHz to 6 GHz ≤-90 dBm typ. 6 GHz to 13.5 GHz ≤-90 dBm Nominal 13.5 GHz to 26.5 GHz ≤-90 dBm Nominal. 26.5 GHz to 40 GHz ≤-80 dBm Nominal.</p>
Connector	
RF input Connector	<p>With MS2830A-040/041/043/044, Front panel, N-J, 50 Ω VSWR: Input attenuator ≥10 dB, 18°C to 28°C ≤1.2 (Nominal)(40 MHz ≤ frequency ≤ 3 GHz) ≤1.5 (Nominal)(3 GHz < frequency ≤ 6 GHz) ≤1.6 (Nominal)(6 GHz < frequency ≤ 13.5 GHz) ≤1.9 (Nominal)(13.5 GHz < frequency ≤ 26.5 GHz)</p> <p>With MS2830A-045, Front panel, N-J, 50 Ω VSWR: Input attenuator ≥10 dB, 18°C to 28°C ≤1.2 (Nominal)(40 MHz ≤ frequency ≤ 3 GHz) ≤1.3 (Nominal)(3 GHz < frequency ≤ 6 GHz) ≤1.3 (Nominal)(6 GHz < frequency ≤ 13.5 GHz) ≤1.4 (Nominal)(13.5 GHz < frequency ≤ 26.5 GHz) ≤1.6 (Nominal)(26.5 GHz < frequency ≤ 40 GHz) ≤1.6 (Nominal)(40 GHz < frequency ≤ 43 GHz) 40 GHz < frequency ≤ 43 GHz is a value with the V-K converter mounted and included</p>

Table 1.3.1-1 Specifications for Mainframe (Continued)

Item	Specification
RF output Connector	This is available when the Option 020/120/021/121 is installed. Front panel, N-J, 50 Ω (Nominal value) Refer to <i>MS2830A Signal Analyzer Vector Signal Generator Operation Manual Operation</i> .
1st Local Output Output Input Connector	This is available when the Option 044/045 is installed. Connector for External Mixer Local signal, bias current Local signal: Frequency 5 GHz to 10 GHz, output level ≥ 10 dBm typ. IF signal: Frequency 1875 MHz Front panel, SMA-J, 50 Ω (Nominal)
External reference input Connector Frequency Operating range Input Level	Rear panel, BNC-J, 50 Ω (Nominal value) 5 MHz/10 MHz/13 MHz ± 1 ppm -15 dBm \leq level $\leq +20$ dBm, 50 Ω (AC coupling)
Reference signal output Connector Frequency Output Level	Rear panel, BNC-J, 50 Ω (Nominal value) 10 MHz ≥ 0 dBm (AC coupling)
Sweep Status Output Connector Output Level	Rear panel, BNC-J TTL level (high level at sweep or waveform acquisition)
SA Trigger Input Connector Input Level	Rear panel, BNC-J TTL level
SG Trigger Input Connector Input Level	Available with option 020/120/021/121 installed. Rear panel, BNC-J TTL level
External controls	Control from external controller (except power)
Ethernet (10/100/1000Base-T) Connector	Connector Rear panel, RJ-45
GPIB Connector Interface function	IEEE488.2 compatible Rear panel, IEEE488 bus connector SH1, AH1, T6, L4, SR1, RL1, PP0, DC1, DT0, C0, E2
USB (B) Connector	USB2.0 compatible Rear panel, USB-B connector

Table 1.3.1-1 Specifications for Mainframe (Continued)

Item	Specification																																				
USB Connector	Enables waveform hard copy to USB compatible external device and saving mainframe setting parameters USB 2.0 compatible USB-A connector (2 ports on front panel, 2 ports on rear panel)																																				
Monitor Output Connector	Rear panel, VGA compatibility, mini D-SUB 15 pin																																				
Aux Connector	Used for the input/output of an auxiliary device. Rear panel, 50 pins (DX10A-50S equivalent part)																																				
IF Output Connector Output frequency Gain	This is available when the Option 044/045 is installed. Outputs the signal for the 1st IF output connector before band filtering. Rear panel, SMA-J, 50 Ω (Nominal) 1875 MHz -10 dB (Nominal, ATT = 0 dB, at 10 GHz input frequency)																																				
Screen	XGA color LCD (Resolution: 1024×768) Size: 8.4” (213 mm diagonal)																																				
External Mixer Frequency Frequency band configuration Amplitude Input/Output Display gain	This is available when the Option MS2830A-044/045 is installed. Frequency range 26.5 GHz to 110 GHz <table border="1" data-bbox="534 1099 1133 1489"> <thead> <tr> <th>Band</th> <th>Frequency range</th> <th>Mixing order</th> </tr> </thead> <tbody> <tr><td>Band A</td><td>26.5G to 40.0 GHz</td><td>4+</td></tr> <tr><td>Band Q</td><td>33.0G to 50.0 GHz</td><td>5+</td></tr> <tr><td>Band U</td><td>40.0G to 60.0 GHz</td><td>6+</td></tr> <tr><td>Band V</td><td>50.0G to 75.0 GHz</td><td>8+</td></tr> <tr><td>Band E</td><td>60.0G to 90.0 GHz</td><td>9+</td></tr> <tr><td>Band W</td><td>75.0G to 110.0 GHz</td><td>11+</td></tr> <tr><td>Band F</td><td>90.0G to 140.0 GHz</td><td>14+</td></tr> <tr><td>Band D</td><td>110.0G to 170.0 GHz</td><td>17+</td></tr> <tr><td>Band G</td><td>140.0G to 220.0 GHz</td><td>22+</td></tr> <tr><td>Band Y</td><td>170.0G to 260.0 GHz</td><td>26+</td></tr> <tr><td>Band J</td><td>220.0G to 325.0 GHz</td><td>33+</td></tr> </tbody> </table> Setting range of mixer conversion loss 0 to 99.9 dB Maximum input level Depends on External Mixer Average noise level Depends on External Mixer Frequency response Depends on External Mixer Applicable mixer: Two-port mixer only Local frequency 5 to 10 GHz IF frequency 1875 MHz 0±2 dB at External mixer input level: -10 dBm. mixer conversion loss: 15 dB	Band	Frequency range	Mixing order	Band A	26.5G to 40.0 GHz	4+	Band Q	33.0G to 50.0 GHz	5+	Band U	40.0G to 60.0 GHz	6+	Band V	50.0G to 75.0 GHz	8+	Band E	60.0G to 90.0 GHz	9+	Band W	75.0G to 110.0 GHz	11+	Band F	90.0G to 140.0 GHz	14+	Band D	110.0G to 170.0 GHz	17+	Band G	140.0G to 220.0 GHz	22+	Band Y	170.0G to 260.0 GHz	26+	Band J	220.0G to 325.0 GHz	33+
Band	Frequency range	Mixing order																																			
Band A	26.5G to 40.0 GHz	4+																																			
Band Q	33.0G to 50.0 GHz	5+																																			
Band U	40.0G to 60.0 GHz	6+																																			
Band V	50.0G to 75.0 GHz	8+																																			
Band E	60.0G to 90.0 GHz	9+																																			
Band W	75.0G to 110.0 GHz	11+																																			
Band F	90.0G to 140.0 GHz	14+																																			
Band D	110.0G to 170.0 GHz	17+																																			
Band G	140.0G to 220.0 GHz	22+																																			
Band Y	170.0G to 260.0 GHz	26+																																			
Band J	220.0G to 325.0 GHz	33+																																			

Table 1.3.1-1 Specifications for Mainframe (Continued)

Item	Specification
Overall Specifications	
Mass, Weight Dimensions Weight	177 mm (h)×426 mm (w)×390 mm (d) (excluding protrusions) ≤ 14.5 kg (with MS2830A-040 or -041 and MS2830A-020 or -021 options installed; excludes all other options) ≤ 13.5 kg (with MS2830A-043 options installed; excludes all other options) ≤ 15 kg (with MS2830A-044 or -045 installed; excludes all other options)
Power Supply Voltage Frequency Power consumption	Rated Voltage: AC 100 to 120 V or 200 to 240 V * 50 Hz to 60 Hz ≤350 VA (including all options, maximum value) 110VA Nominal (With MS2830-040 or 041 installed, excluding other options) 130VA Nominal (With MS2830-043 installed, excluding other options) 170VA Nominal (With MS2830-040/041, -020/021 and -022 installed, excluding other options) 190VA Nominal (With MS2830-043, -020/021, and -022 installed, excluding other options)
Temperature Operating temperature Storage temperature	5°C to 45°C -20°C to +60°C
Environment Performance	
Conducted emission	Conforms to EN 61326-1: 2006
Radiated emission	Conforms to EN 61326-1: 2006
Harmonic current emission	Conforms to EN 61000-3-2: 2006 +A1:2009 A2:2009
Electrostatic discharge	Conforms to EN 61326-1: 2006
Electromagnetic field immunity	Conforms to EN 61326-1: 2006

*: Operating voltage: within the range of +10% to -15% from the rated voltage

Table 1.3.1-1 Specifications for Mainframe (Continued)

Item	Specification
Fast transient/burst	Conforms to EN 61326-1: 2006
Surge	Conforms to EN 61326-1: 2006
Conducted RF	Conforms to EN 61326-1: 2006
Power frequency magnetic field	Conforms to EN 61326-1: 2006
Voltage dips/short interruption	Conforms to EN 61326-1: 2006

Table 1.3.1-2 Specifications for Signal Analyzer Function

Item	Specification
Common	
Trace mode	Spectrum, Power vs Time, Frequency vs Time, CCDF, Spectrogram, No Trace
Bandwidth	<p>Specifies the capture analysis bandwidth from the center frequency 1 kHz to 10 MHz (1-2.5-5 sequence) (With MS2830A-006/106)</p> <p>1 kHz to 25 MHz (1-2.5-5 sequence), 31.25 MHz (With MS2830A-005/105, MS2830A-007 or MS2830A-009/109 installed.)</p> <p>1 kHz to 25 MHz (1-2.5-5 sequence), 31.25 MHz, 50 MHz, 62.5 MHz (With MS2830A-077/177 installed.)</p> <p>1 kHz to 25 MHz (1-2.5-5 sequence), 31.25 MHz, 50 MHz, 62.5 MHz, 100 MHz, 125 MHz (With MS2830A-078/178 installed.)</p>
Sampling rate	<p>Automatically set depending on analysis bandwidth 2 kHz to 20 MHz (1-2-5 sequence) (With MS2830A-006/106)</p> <p>2 kHz to 50 MHz (1-2-5 sequence) (With MS2830A-005/105, MS2830A-007 or MS2830A-009/109 installed.)</p> <p>2 kHz to 100 MHz (1-2-5 sequence) (With MS2830A-077/177 installed.)</p> <p>2 kHz to 200 MHz (1-2-5 sequence) (With MS2830A-078/178 installed.)</p>

Table 1.3.1-2 Specifications for Signal Analyzer Function (Continued)

Item	Specification
<p>Capture time</p> <p> Capture Time Length</p> <p> Minimum capture time:</p> <p> Maximum capture time:</p> <p> Setting mode</p> <p> Capture Time Length</p> <p> Minimum capture time:</p> <p> Maximum capture time:</p> <p> Setting mode</p> <p> Capture Time Length</p> <p> Minimum capture time:</p> <p> Maximum capture time:</p> <p> Setting mode</p>	<p>Sets the capture time length</p> <p>2 μs to 50 ms (determined depending on analysis bandwidth)</p> <p>2 s to 2000 s (determined depending on analysis bandwidth)</p> <p>Auto, Manual</p> <p>(With MS2830A-077/177/078/178 not installed or Bandwidth \leq 31.25 MHz.)</p> <p>Sets the capture time length.</p> <p>1 μs (determined depending on analysis bandwidth)</p> <p>500 ms (determined depending on analysis bandwidth)</p> <p>Auto, Manual</p> <p>(With MS2830A-077/177 installed and Bandwidth > 31.25 MHz.)</p> <p>Sets the capture time length.</p> <p>500 ns to 1 μs (determined depending on analysis bandwidth)</p> <p>500 ms (determined depending on analysis bandwidth)</p> <p>Auto, Manual</p> <p>(With MS2830A-078/178 installed and Bandwidth > 31.25 MHz.)</p>
<p>Trigger</p> <p> Trigger mode</p>	<p>Free Run (Trig Off), Video, Wide IF Video, Frame, External (TTL) SG Marker (With Option 020/120/021/121)</p>
<p>ADC resolution</p>	<p>16bits</p> <p>(With MS2830A-077/177/078/178 not installed or Bandwidth \leq 31.25 MHz.)</p>
<p>Spectrum indicator function</p>	
<p>Function overview</p>	<p>Displays the spectrum for arbitrary time length and frequency range in the acquired waveform data.</p>
<p>Analysis time range</p> <p> Analysis Start Time</p> <p> Analysis Time Length</p> <p> Setting mode</p>	<p>Sets analysis start time position from beginning of waveform data.</p> <p>Sets analysis time span.</p> <p>Auto, Manual</p>

Table 1.3.1-2 Specifications for Signal Analyzer Function (Continued)

Item	Specification
Frequency	Center frequency and SPAN can be set within the frequency range in waveform data.
Frequency settings	<p>0 MHz to 3.6 GHz (MS2830A-040) 0 MHz to 6 GHz (MS2830A-041) 0 MHz to 13.5 GHz (MS2830A-043) 0 MHz to 26.5 GHz (MS2830A-044) 0 MHz to 43 GHz (MS2830A-045) (With MS2830A-077/177/078/178 not installed or Bandwidth \leq 31.25 MHz.)</p> <p>300MHz to 3.6GHz (MS2830A-040) 300MHz to 6GHz (MS2830A-041) 300MHz to 13.5GHz (MS2830A-043) (With MS2830A-077/177/078/178 installed and Bandwidth $>$ 31.25 MHz.)</p> <p>300MHz to 6GHz (MS2830A-044) 300MHz to 6GHz (MS2830A-045) (With MS2830A-077/177/078/178 installed but MS2830A-067/167 not installed and Bandwidth $>$ 31.25 MHz.)</p> <p>300MHz to 26.5GHz (MS2830A-044) 300MHz to 43GHz (MS2830A-045) (With MS2830A-077/177/078/178 and MS2830A-067/167 installed and Bandwidth $>$ 31.25 MHz.)</p>
Display frequency accuracy	\pm [Indicator frequency \times reference frequency accuracy + SPAN frequency \times reference frequency accuracy + RBW \times 0.05 + 2 \times N + SPAN frequency / (Trace point count - 1)] Hz N: Mixer harmonic order
Resolution bandwidth (RBW)	<p>Setting range Selectivity 1 Hz to 1 MHz (1-3 sequence), (-60 dB/-3 dB) 4.5:1, nominal value (With MS2830A-077/177/078/178 not installed or Bandwidth \leq 31.25 MHz.)</p> <p>Setting range Selectivity 1 Hz to 3 MHz (1-3 sequence) (-60 dB/-3 dB) 4.5:1, Nominal value (With MS2830A-077/177 installed and Bandwidth $>$ 31.25 MHz.)</p> <p>Setting range Selectivity 1 Hz to 10 MHz (1-3 sequence) (-60 dB/-3 dB) 4.5:1, Nominal value (With MS2830A-078/178 installed and Bandwidth $>$ 31.25 MHz.)</p>

Table 1.3.1-2 Specifications for Signal Analyzer Function (Continued)

Item	Specification
Absolute amplitude accuracy	<p>After CAL execution at 18° to 28°C, RBW = Auto, Time Detection = Average, Marker Result = Integration or Peak (Accuracy), center frequency, CW, excluding the noise floor effect</p> <p>With Preamplifier turned off: Input attenuator ≥ 10 dB, Mixer input level ≤ -10 dBm</p> <p>With Preamplifier turned on: Input attenuator = 10 dB, preamplifier input level ≤ -30 dBm,</p> <p>With MS2830A-041/042/043 installed, Without MS2830A-008/108 or with Preamplifier turned off: ± 0.5 dB (300 kHz \leq frequency < 4 GHz, Frequency Band Mode: Normal) (300 kHz \leq frequency < 3.5 GHz, Frequency Band Mode: Normal)</p> <p>± 1.8 dB (4 GHz \leq frequency ≤ 6 GHz, Frequency Band Mode: Normal) (3.5 GHz \leq frequency ≤ 6 GHz, Frequency Band Mode: Spurious)</p> <p>± 1.8 dB (6 GHz $<$ frequency ≤ 13.5 GHz)</p> <p>With MS2830A-008/108 and with Preamplifier turned on: ± 1.0 dB (300 kHz \leq frequency < 4 GHz, Frequency Band Mode: Normal) (300 kHz \leq frequency < 3.5 GHz, Frequency Band Mode: Spurious)</p> <p>± 1.8 dB (4 GHz \leq frequency ≤ 6 GHz, Frequency Band Mode: Normal) (3.5 GHz \leq frequency ≤ 6 GHz, Frequency Band Mode: Spurious)</p>

Table 1.3.1-2 Specifications for Signal Analyzer Function (Continued)

Item	Specification
Absolute amplitude accuracy (Continued)	<p>With MS2830A-044/045 installed, Without MS2830A-068/168 or with Preamplifier turned off:</p> <p>±0.5 dB (300 kHz ≤ frequency < 4 GHz, Frequency Band Mode: Normal) (300 kHz ≤ frequency < 3.5 GHz, Frequency Band Mode: Spurious)</p> <p>±1.8 dB (4 GHz ≤ frequency ≤ 6 GHz, Frequency Band Mode: Normal) (3.5 GHz ≤ frequency ≤ 4 GHz, Frequency Band Mode: Spurious)</p> <p>±1.8 dB (6 GHz ≤ frequency ≤ 13.8 GHz, Frequency Band Mode: Normal) (4 GHz ≤ frequency ≤ 13.8 GHz, Frequency Band Mode: Spurious)</p> <p>±3.0 dB (13.8 GHz < frequency ≤ 26.5 GHz)</p> <p>±3.0 dB (26.5 GHz < frequency ≤ 40 GHz)</p> <p>±3.5 dB Nominal (40 GHz < frequency ≤ 43 GHz)</p> <p>With MS2830A-044/045 installed, With MS2830A-068/168 and Preamplifier turned on:</p> <p>±1.0 dB (300 kHz ≤ frequency < 4 GHz, Frequency Band Mode: Normal) (300 kHz ≤ frequency < 3.5 GHz, Frequency Band Mode: Spurious)</p> <p>±1.8 dB (4 GHz ≤ frequency ≤ 6 GHz, Frequency Band Mode: Normal) (3.5 GHz ≤ frequency ≤ 4 GHz, Frequency Band Mode: Spurious)</p> <p>±2.0 dB (6 GHz < frequency ≤ 13.8 GHz, Frequency Band Mode: Normal) (4 GHz < frequency ≤ 13.8 GHz, Frequency Band Mode: Spurious)</p> <p>±3.0 dB (13.8 GHz < frequency ≤ 26.5 GHz)</p> <p>±4.0 dB (26.5 GHz < frequency ≤ 40 GHz)</p> <p>±4.0 dB Nominal (40 GHz < frequency ≤ 43 GHz)</p> <p>The absolute amplitude accuracy is calculated from an RSS (root summed square) error of the RF frequency characteristics, linear error and input attenuator switching error.</p>

Table 1.3.1-2 Specifications for Signal Analyzer Function (Continued)

Item	Specification
In-band frequency characteristics	<p>With MS2830A-040/041/043 installed, (With MS2830A-077/177/078/178 not installed or Bandwidth ≤ 31.25 MHz.) On the basis of a level of the center frequency, at 18°C to 28°C in center frequency ± 10 MHz ± 0.31 dB (30 MHz \leq frequency \leq 4 GHz, Frequency Band Mode: Normal) (30 MHz \leq frequency < 3.5 GHz, Frequency Band Mode: Spurious)</p> <p>With MS2830A-044/045 installed, (With MS2830A-077/177/078/178 not installed or Bandwidth ≤ 31.25 MHz.) On the basis of a level of the center frequency, at 18°C to 28°C in center frequency ± 10 MHz ± 0.31 dB (30 MHz \leq frequency \leq 4 GHz, Frequency Band Mode: Normal) (30 MHz \leq frequency < 3.5 GHz, Frequency Band Mode: Spurious)</p>

Table 1.3.1-2 Specifications for Signal Analyzer Function (Continued)

Item	Specification																														
Display average noise level	<p>With MS2830A-040/041/043 installed, (With MS2830A-077/177/078/178 not installed or Bandwidth \leq 31.25 MHz.)</p> <p>Without MS2830A-062/066, Without MS2830A-008/108 or with Preamplifier turned off: At 18°C to 28°C, input attenuator = 0 dB,</p> <table data-bbox="603 663 1310 819"> <tr><td>100 kHz</td><td>-131.5 [dBm/Hz]</td></tr> <tr><td>1 MHz</td><td>-141.5 [dBm/Hz]</td></tr> <tr><td>30 MHz\leqfrequency$<$1 GHz</td><td>-150.5 [dBm/Hz]</td></tr> <tr><td>1 GHz\leqfrequency$<$2.4 GHz</td><td>-148.5 [dBm/Hz]</td></tr> <tr><td>2.4 GHz\leqfrequency\leq3.5 GHz</td><td>-146.5 [dBm/Hz]</td></tr> </table> <p>With MS2830A-041/043 3.5 GHz$<$frequency\leq6 GHz -143.5 [dBm/Hz]</p> <p>With MS2830A-043 6 GHz$<$frequency\leq13.5 GHz -139.5 [dBm/Hz]</p> <p>Without MS2830A-062/066, With MS2830A-008/108 or with Preamplifier turned on: At 18°C to 28°C, input attenuator = 0 dB,</p> <table data-bbox="603 1106 1426 1263"> <tr><td>100 kHz</td><td>-144.5 [dBm/Hz] Nominal</td></tr> <tr><td>1 MHz</td><td>-153.5 [dBm/Hz]</td></tr> <tr><td>30 MHz\leqfrequency$<$1 GHz</td><td>-160.5 [dBm/Hz]</td></tr> <tr><td>1 GHz\leqfrequency$<$2 GHz</td><td>-159.5 [dBm/Hz]</td></tr> <tr><td>2 GHz\leqfrequency\leq3.5 GHz</td><td>-157.5 [dBm/Hz]</td></tr> </table> <p>With MS2830A-041/043, Frequency Band Mode: Normal 3.5 GHz$<$frequency\leq4 GHz -154.5 [dBm/Hz]</p> <p>With MS2830A-041/043, Frequency Band Mode: Spurious 3.5 GHz$<$frequency\leq4 GHz -154.5 [dBm/Hz]</p> <p>With MS2830A-041/043 4 GHz$<$frequency\leq6 GHz -154.5 [dBm/Hz]</p> <p>With MS2830A-062/066 installed, Without MS2830A-008/108 or with Preamplifier turned off: At 18°C to 28°C, input attenuator = 0 dB,</p> <table data-bbox="603 1615 1310 1771"> <tr><td>100 kHz</td><td>-130.5 [dBm/Hz]</td></tr> <tr><td>1 MHz</td><td>-140.5 [dBm/Hz]</td></tr> <tr><td>30 MHz \leq Frequency $<$ 1 GHz</td><td>-149.5 [dBm/Hz]</td></tr> <tr><td>1 GHz \leq frequency $<$ 2.4 GHz</td><td>-147.5 [dBm/Hz]</td></tr> <tr><td>2.4 GHz \leq Frequency \leq 3.5 GHz</td><td>-144.5 [dBm/Hz]</td></tr> </table> <p>With MS2830A-041/043 installed, 3.5 GHz $<$ Frequency \leq 6 GHz -141.5 [dBm/Hz]</p> <p>With MS2830A-043 installed, 6 GHz $<$ Frequency \leq 13.5 GHz -139.5 [dBm/Hz]</p>	100 kHz	-131.5 [dBm/Hz]	1 MHz	-141.5 [dBm/Hz]	30 MHz \leq frequency $<$ 1 GHz	-150.5 [dBm/Hz]	1 GHz \leq frequency $<$ 2.4 GHz	-148.5 [dBm/Hz]	2.4 GHz \leq frequency \leq 3.5 GHz	-146.5 [dBm/Hz]	100 kHz	-144.5 [dBm/Hz] Nominal	1 MHz	-153.5 [dBm/Hz]	30 MHz \leq frequency $<$ 1 GHz	-160.5 [dBm/Hz]	1 GHz \leq frequency $<$ 2 GHz	-159.5 [dBm/Hz]	2 GHz \leq frequency \leq 3.5 GHz	-157.5 [dBm/Hz]	100 kHz	-130.5 [dBm/Hz]	1 MHz	-140.5 [dBm/Hz]	30 MHz \leq Frequency $<$ 1 GHz	-149.5 [dBm/Hz]	1 GHz \leq frequency $<$ 2.4 GHz	-147.5 [dBm/Hz]	2.4 GHz \leq Frequency \leq 3.5 GHz	-144.5 [dBm/Hz]
100 kHz	-131.5 [dBm/Hz]																														
1 MHz	-141.5 [dBm/Hz]																														
30 MHz \leq frequency $<$ 1 GHz	-150.5 [dBm/Hz]																														
1 GHz \leq frequency $<$ 2.4 GHz	-148.5 [dBm/Hz]																														
2.4 GHz \leq frequency \leq 3.5 GHz	-146.5 [dBm/Hz]																														
100 kHz	-144.5 [dBm/Hz] Nominal																														
1 MHz	-153.5 [dBm/Hz]																														
30 MHz \leq frequency $<$ 1 GHz	-160.5 [dBm/Hz]																														
1 GHz \leq frequency $<$ 2 GHz	-159.5 [dBm/Hz]																														
2 GHz \leq frequency \leq 3.5 GHz	-157.5 [dBm/Hz]																														
100 kHz	-130.5 [dBm/Hz]																														
1 MHz	-140.5 [dBm/Hz]																														
30 MHz \leq Frequency $<$ 1 GHz	-149.5 [dBm/Hz]																														
1 GHz \leq frequency $<$ 2.4 GHz	-147.5 [dBm/Hz]																														
2.4 GHz \leq Frequency \leq 3.5 GHz	-144.5 [dBm/Hz]																														

Table 1.3.1-2 Specifications for Signal Analyzer Function (Continued)

Item	Specification																												
Display average noise level (Continued)	<p>With MS2830A-062/066 installed, With MS2830A-008/108 and with Preamplifier turned on: At 18°C to 28°C, input attenuator = 0 dB,</p> <table border="0"> <tr> <td>100 kHz</td> <td>-143.5 [dBm/Hz] Nominal</td> </tr> <tr> <td>1 MHz</td> <td>-152.5 [dBm/Hz]</td> </tr> <tr> <td>30 MHz ≤ Frequency < 1 GHz</td> <td>-159.5 [dBm/Hz]</td> </tr> <tr> <td>1 GHz ≤ Frequency < 2 GHz</td> <td>-158.5 [dBm/Hz]</td> </tr> <tr> <td>2 GHz ≤ Frequency ≤ 3.5 GHz</td> <td>-155.5 [dBm/Hz]</td> </tr> </table> <p>With MS2830A-041/043 installed, Frequency Band Mode: Normal 3.5 GHz < Frequency ≤ 4 GHz -151.5 [dBm/Hz]</p> <p>With MS2830A-041/043 installed, Frequency Band Mode: Spurious 3.5 GHz < Frequency ≤ 4 GHz -151.5 [dBm/Hz]</p> <p>With MS2830A-041/043 installed, 4 GHz < Frequency ≤ 6 GHz -151.5 [dBm/Hz]</p> <p>With MS2830A-040/041/043 installed, With MS2830A-077/177/078/178, analysis bandwidth > 31.25MHz</p> <p>Without MS2830A-062/066, Without MS2830A-008/108, or with Preamplifier turned off At 18°C to 28°C, input attenuator = 0 dB,</p> <table border="0"> <tr> <td>300 MHz ≤ Frequency < 1 GHz</td> <td>-146.5 [dBm/Hz]</td> </tr> <tr> <td>1 GHz ≤ Frequency < 2.4 GHz</td> <td>-144.5 [dBm/Hz]</td> </tr> <tr> <td>2.4 GHz ≤ Frequency ≤ 3.5 GHz</td> <td>-142.5 [dBm/Hz]</td> </tr> </table> <p>With MS2830A-041/043 installed, 3.5 GHz < Frequency ≤ 6 GHz -139.5 [dBm/Hz]</p> <p>With MS2830A-043 installed, 6 GHz < Frequency ≤ 13.5 GHz -135.5 [dBm/Hz]</p> <p>Without MS2830A-062/066, With MS2830A-008/108, and with Preamplifier turned on At 18°C to 28°C, input attenuator = 0 dB,</p> <table border="0"> <tr> <td>300 MHz ≤ Frequency < 1 GHz</td> <td>-156.5 [dBm/Hz]</td> </tr> <tr> <td>1 GHz ≤ Frequency < 2.4 GHz</td> <td>-155.5 [dBm/Hz]</td> </tr> <tr> <td>2.4 GHz ≤ Frequency ≤ 3.5 GHz</td> <td>-153.5 [dBm/Hz]</td> </tr> </table> <p>With MS2830A-043 installed, 3.5 GHz < Frequency ≤ 6 GHz -150.5 [dBm/Hz]</p> <p>With MS2830A-062/066, Without MS2830A-008/108, or with Preamplifier turned off At 18°C to 28°C, input attenuator = 0 dB,</p> <table border="0"> <tr> <td>300 MHz ≤ Frequency < 1 GHz</td> <td>-143.5 [dBm/Hz]</td> </tr> <tr> <td>1 GHz ≤ Frequency < 2.4 GHz</td> <td>-141.5 [dBm/Hz]</td> </tr> <tr> <td>2.4 GHz ≤ Frequency ≤ 3.5 GHz</td> <td>-138.5 [dBm/Hz]</td> </tr> </table> <p>With MS2830A-041/043 installed, 3.5 GHz < Frequency ≤ 6 GHz -135.5 [dBm/Hz]</p> <p>With MS2830A-043 installed, 6 GHz < Frequency ≤ 13.5 GHz -135.5 [dBm/Hz]</p>	100 kHz	-143.5 [dBm/Hz] Nominal	1 MHz	-152.5 [dBm/Hz]	30 MHz ≤ Frequency < 1 GHz	-159.5 [dBm/Hz]	1 GHz ≤ Frequency < 2 GHz	-158.5 [dBm/Hz]	2 GHz ≤ Frequency ≤ 3.5 GHz	-155.5 [dBm/Hz]	300 MHz ≤ Frequency < 1 GHz	-146.5 [dBm/Hz]	1 GHz ≤ Frequency < 2.4 GHz	-144.5 [dBm/Hz]	2.4 GHz ≤ Frequency ≤ 3.5 GHz	-142.5 [dBm/Hz]	300 MHz ≤ Frequency < 1 GHz	-156.5 [dBm/Hz]	1 GHz ≤ Frequency < 2.4 GHz	-155.5 [dBm/Hz]	2.4 GHz ≤ Frequency ≤ 3.5 GHz	-153.5 [dBm/Hz]	300 MHz ≤ Frequency < 1 GHz	-143.5 [dBm/Hz]	1 GHz ≤ Frequency < 2.4 GHz	-141.5 [dBm/Hz]	2.4 GHz ≤ Frequency ≤ 3.5 GHz	-138.5 [dBm/Hz]
100 kHz	-143.5 [dBm/Hz] Nominal																												
1 MHz	-152.5 [dBm/Hz]																												
30 MHz ≤ Frequency < 1 GHz	-159.5 [dBm/Hz]																												
1 GHz ≤ Frequency < 2 GHz	-158.5 [dBm/Hz]																												
2 GHz ≤ Frequency ≤ 3.5 GHz	-155.5 [dBm/Hz]																												
300 MHz ≤ Frequency < 1 GHz	-146.5 [dBm/Hz]																												
1 GHz ≤ Frequency < 2.4 GHz	-144.5 [dBm/Hz]																												
2.4 GHz ≤ Frequency ≤ 3.5 GHz	-142.5 [dBm/Hz]																												
300 MHz ≤ Frequency < 1 GHz	-156.5 [dBm/Hz]																												
1 GHz ≤ Frequency < 2.4 GHz	-155.5 [dBm/Hz]																												
2.4 GHz ≤ Frequency ≤ 3.5 GHz	-153.5 [dBm/Hz]																												
300 MHz ≤ Frequency < 1 GHz	-143.5 [dBm/Hz]																												
1 GHz ≤ Frequency < 2.4 GHz	-141.5 [dBm/Hz]																												
2.4 GHz ≤ Frequency ≤ 3.5 GHz	-138.5 [dBm/Hz]																												

Table 1.3.1-2 Specifications for Signal Analyzer Function (Continued)

Item	Specification																																														
Display average noise level (Continued)	<p>With MS2830A-062/066, With MS2830A-008/108, and with Preamplifier turned on At 18°C to 28°C, input attenuator = 0 dB,</p> <table border="0"> <tr> <td>300 MHz ≤ Frequency < 1 GHz</td> <td>-153.5 [dBm/Hz]</td> </tr> <tr> <td>1 GHz ≤ Frequency < 2.4 GHz</td> <td>-152.5 [dBm/Hz]</td> </tr> <tr> <td>2.4 GHz ≤ Frequency ≤ 3.5 GHz</td> <td>-149.5 [dBm/Hz]</td> </tr> </table> <p>With MS2830A-043 installed, 3.5 GHz ≤ Frequency < 6 GHz -145.5 [dBm/Hz]</p> <p>With MS2830A-044/045 installed, Without MS2830A-077/177/078/178, or analysis bandwidth ≤ 31.25MHz</p> <p>Without MS2830A-067/167/068/168 or with Preamplifier turned off, Frequency Band Mode: Normal</p> <table border="0"> <tr> <td>100 kHz</td> <td>-131.5 [dBm/Hz]</td> </tr> <tr> <td>1 MHz</td> <td>-141.5 [dBm/Hz]</td> </tr> <tr> <td>30 MHz ≤ frequency < 1 GHz</td> <td>-150.5 [dBm/Hz]</td> </tr> <tr> <td>1 GHz ≤ frequency < 2.4 GHz</td> <td>-147.5 [dBm/Hz]</td> </tr> <tr> <td>2.4 GHz ≤ frequency ≤ 3.5 GHz</td> <td>-144.5 [dBm/Hz]</td> </tr> <tr> <td>3.5 GHz < frequency ≤ 4 GHz</td> <td>-141.5 [dBm/Hz]</td> </tr> <tr> <td>4 GHz < frequency ≤ 6 GHz</td> <td>-141.5 [dBm/Hz]</td> </tr> <tr> <td>6 GHz < frequency ≤ 13.5 GHz</td> <td>-148.5 [dBm/Hz]</td> </tr> <tr> <td>13.5 GHz < frequency ≤ 18.3 GHz</td> <td>-146.5 [dBm/Hz]</td> </tr> <tr> <td>18.3 GHz < frequency ≤ 26.5 GHz</td> <td>-143.5 [dBm/Hz]</td> </tr> </table> <p>With MS2830A-045, 26.5 GHz < frequency ≤ 34 GHz -143.5 [dBm/Hz] 34 GHz < frequency ≤ 40 GHz -141.5 [dBm/Hz] 40 GHz < frequency ≤ 43 GHz -137.5 [dBm/Hz]</p> <p>Without MS2830A-067/167 and with MS2830A-068/168, and with Preamplifier turned off, Frequency Band Mode: Normal</p> <table border="0"> <tr> <td>100 kHz</td> <td>-131.5 [dBm/Hz]</td> </tr> <tr> <td>1 MHz</td> <td>-141.5 [dBm/Hz]</td> </tr> <tr> <td>30 MHz ≤ frequency < 1 GHz</td> <td>-150.5 [dBm/Hz]</td> </tr> <tr> <td>1 GHz ≤ frequency < 2.4 GHz</td> <td>-147.5 [dBm/Hz]</td> </tr> <tr> <td>2.4 GHz ≤ frequency ≤ 3.5 GHz</td> <td>-144.5 [dBm/Hz]</td> </tr> <tr> <td>3.5 GHz < frequency ≤ 4 GHz</td> <td>-141.5 [dBm/Hz]</td> </tr> <tr> <td>4 GHz < frequency ≤ 6 GHz</td> <td>-141.5 [dBm/Hz]</td> </tr> <tr> <td>6 GHz < frequency ≤ 13.5 GHz</td> <td>-144.5 [dBm/Hz]</td> </tr> <tr> <td>13.5 GHz < frequency ≤ 18.3 GHz</td> <td>-142.5 [dBm/Hz]</td> </tr> <tr> <td>18.3 GHz < frequency ≤ 26.5 GHz</td> <td>-138.5 [dBm/Hz]</td> </tr> </table> <p>With MS2830A-045, 26.5 GHz < frequency ≤ 34 GHz -138.5 [dBm/Hz] 34 GHz < frequency ≤ 40 GHz -132.5 [dBm/Hz] 40 GHz < frequency ≤ 43 GHz -129.5 [dBm/Hz]</p>	300 MHz ≤ Frequency < 1 GHz	-153.5 [dBm/Hz]	1 GHz ≤ Frequency < 2.4 GHz	-152.5 [dBm/Hz]	2.4 GHz ≤ Frequency ≤ 3.5 GHz	-149.5 [dBm/Hz]	100 kHz	-131.5 [dBm/Hz]	1 MHz	-141.5 [dBm/Hz]	30 MHz ≤ frequency < 1 GHz	-150.5 [dBm/Hz]	1 GHz ≤ frequency < 2.4 GHz	-147.5 [dBm/Hz]	2.4 GHz ≤ frequency ≤ 3.5 GHz	-144.5 [dBm/Hz]	3.5 GHz < frequency ≤ 4 GHz	-141.5 [dBm/Hz]	4 GHz < frequency ≤ 6 GHz	-141.5 [dBm/Hz]	6 GHz < frequency ≤ 13.5 GHz	-148.5 [dBm/Hz]	13.5 GHz < frequency ≤ 18.3 GHz	-146.5 [dBm/Hz]	18.3 GHz < frequency ≤ 26.5 GHz	-143.5 [dBm/Hz]	100 kHz	-131.5 [dBm/Hz]	1 MHz	-141.5 [dBm/Hz]	30 MHz ≤ frequency < 1 GHz	-150.5 [dBm/Hz]	1 GHz ≤ frequency < 2.4 GHz	-147.5 [dBm/Hz]	2.4 GHz ≤ frequency ≤ 3.5 GHz	-144.5 [dBm/Hz]	3.5 GHz < frequency ≤ 4 GHz	-141.5 [dBm/Hz]	4 GHz < frequency ≤ 6 GHz	-141.5 [dBm/Hz]	6 GHz < frequency ≤ 13.5 GHz	-144.5 [dBm/Hz]	13.5 GHz < frequency ≤ 18.3 GHz	-142.5 [dBm/Hz]	18.3 GHz < frequency ≤ 26.5 GHz	-138.5 [dBm/Hz]
300 MHz ≤ Frequency < 1 GHz	-153.5 [dBm/Hz]																																														
1 GHz ≤ Frequency < 2.4 GHz	-152.5 [dBm/Hz]																																														
2.4 GHz ≤ Frequency ≤ 3.5 GHz	-149.5 [dBm/Hz]																																														
100 kHz	-131.5 [dBm/Hz]																																														
1 MHz	-141.5 [dBm/Hz]																																														
30 MHz ≤ frequency < 1 GHz	-150.5 [dBm/Hz]																																														
1 GHz ≤ frequency < 2.4 GHz	-147.5 [dBm/Hz]																																														
2.4 GHz ≤ frequency ≤ 3.5 GHz	-144.5 [dBm/Hz]																																														
3.5 GHz < frequency ≤ 4 GHz	-141.5 [dBm/Hz]																																														
4 GHz < frequency ≤ 6 GHz	-141.5 [dBm/Hz]																																														
6 GHz < frequency ≤ 13.5 GHz	-148.5 [dBm/Hz]																																														
13.5 GHz < frequency ≤ 18.3 GHz	-146.5 [dBm/Hz]																																														
18.3 GHz < frequency ≤ 26.5 GHz	-143.5 [dBm/Hz]																																														
100 kHz	-131.5 [dBm/Hz]																																														
1 MHz	-141.5 [dBm/Hz]																																														
30 MHz ≤ frequency < 1 GHz	-150.5 [dBm/Hz]																																														
1 GHz ≤ frequency < 2.4 GHz	-147.5 [dBm/Hz]																																														
2.4 GHz ≤ frequency ≤ 3.5 GHz	-144.5 [dBm/Hz]																																														
3.5 GHz < frequency ≤ 4 GHz	-141.5 [dBm/Hz]																																														
4 GHz < frequency ≤ 6 GHz	-141.5 [dBm/Hz]																																														
6 GHz < frequency ≤ 13.5 GHz	-144.5 [dBm/Hz]																																														
13.5 GHz < frequency ≤ 18.3 GHz	-142.5 [dBm/Hz]																																														
18.3 GHz < frequency ≤ 26.5 GHz	-138.5 [dBm/Hz]																																														

Table 1.3.1-2 Specifications for Signal Analyzer Function (Continued)

Item	Specification																																																										
Display average noise level (Continued)	<p>Without MS2830A-067/167 and with MS2830A-068/168, and with Preamplifier turned on, Frequency Band Mode: Normal</p> <table border="0"> <tr> <td>100 kHz</td> <td>-144.5 [dBm/Hz] Nominal</td> </tr> <tr> <td>1 MHz</td> <td>-153.5 [dBm/Hz]</td> </tr> <tr> <td>30 MHz ≤ frequency < 1 GHz</td> <td>-160.5 [dBm/Hz]</td> </tr> <tr> <td>1 GHz ≤ frequency < 2.4 GHz</td> <td>-158.5 [dBm/Hz]</td> </tr> <tr> <td>2.4 GHz ≤ frequency ≤ 3.5 GHz</td> <td>-156.5 [dBm/Hz]</td> </tr> <tr> <td>3.5 GHz < frequency ≤ 4 GHz</td> <td>-152.5 [dBm/Hz]</td> </tr> <tr> <td>4 GHz < frequency ≤ 6 GHz</td> <td>-152.5 [dBm/Hz]</td> </tr> <tr> <td>6 GHz < frequency ≤ 13.5 GHz</td> <td>-157.5 [dBm/Hz]</td> </tr> <tr> <td>13.5 GHz < frequency ≤ 18.3 GHz</td> <td>-155.5 [dBm/Hz]</td> </tr> <tr> <td>18.3 GHz < frequency ≤ 26.5 GHz</td> <td>-153.5 [dBm/Hz]</td> </tr> </table> <p>With MS2830A-045 installed,</p> <table border="0"> <tr> <td>26.5 GHz < frequency ≤ 34 GHz</td> <td>-153.5 [dBm/Hz]</td> </tr> <tr> <td>34 GHz < frequency ≤ 40 GHz</td> <td>-147.5 [dBm/Hz]</td> </tr> <tr> <td>40 GHz < frequency ≤ 43 GHz</td> <td>-144.5 [dBm/Hz]</td> </tr> </table> <p>With MS2830A-044/045 installed, With MS2830A-077/177/078/178, without MS2830A-067/167, analysis bandwidth > 31.25 MHz</p> <p>Without MS2830A-008/108/068/168, or with Preamplifier turned off: At 18°C to 28°C, input attenuator = 0 dB,</p> <table border="0"> <tr> <td>300 MHz ≤ frequency < 1 GHz</td> <td>-146.5 [dBm/Hz]</td> </tr> <tr> <td>1 GHz ≤ frequency < 2.4 GHz</td> <td>-143.5 [dBm/Hz]</td> </tr> <tr> <td>2.4 GHz ≤ frequency ≤ 3.5 GHz</td> <td>-140.5 [dBm/Hz]</td> </tr> <tr> <td>3.5 GHz < frequency ≤ 4 GHz</td> <td>-137.5 [dBm/Hz]</td> </tr> <tr> <td>4 GHz < frequency ≤ 6 GHz</td> <td>-137.5 [dBm/Hz]</td> </tr> </table> <p>With MS2830A-008/108/068/168, and with Preamplifier turned on. At 18°C to 28°C, input attenuator = 0 dB,</p> <table border="0"> <tr> <td>300 MHz ≤ frequency < 1 GHz</td> <td>-156.5 [dBm/Hz]</td> </tr> <tr> <td>1 GHz ≤ frequency < 2 GHz</td> <td>-154.5 [dBm/Hz]</td> </tr> <tr> <td>2 GHz ≤ frequency ≤ 3.5 GHz</td> <td>-152.5 [dBm/Hz]</td> </tr> <tr> <td>3.5 GHz < frequency ≤ 4 GHz</td> <td>-148.5 [dBm/Hz]</td> </tr> <tr> <td>4 GHz < frequency ≤ 6 GHz</td> <td>-148.5 [dBm/Hz]</td> </tr> </table> <p>With MS2830A-077/177/078/178, with MS2830A-067/167, analysis bandwidth > 31.25 MHz</p> <p>Without MS2830A-068/168, At 18°C to 28°C, input attenuator = 0 dB,</p> <table border="0"> <tr> <td>6 GHz ≤ frequency ≤ 13.5 GHz</td> <td>-137.5 [dBm/Hz]</td> </tr> <tr> <td>13.5 GHz < frequency ≤ 18.3 GHz</td> <td>-135.5 [dBm/Hz]</td> </tr> <tr> <td>18.3 GHz < frequency ≤ 26.5 GHz</td> <td>-131.5 [dBm/Hz]</td> </tr> </table> <p>With MS2830A-045 Installed</p> <table border="0"> <tr> <td>26.5 GHz < frequency ≤ 34 GHz</td> <td>-131.5 [dBm/Hz]</td> </tr> <tr> <td>34 GHz < frequency ≤ 40 GHz</td> <td>-125.5 [dBm/Hz]</td> </tr> <tr> <td>40 GHz < frequency ≤ 43 GHz</td> <td>-122.5 [dBm/Hz]</td> </tr> </table>	100 kHz	-144.5 [dBm/Hz] Nominal	1 MHz	-153.5 [dBm/Hz]	30 MHz ≤ frequency < 1 GHz	-160.5 [dBm/Hz]	1 GHz ≤ frequency < 2.4 GHz	-158.5 [dBm/Hz]	2.4 GHz ≤ frequency ≤ 3.5 GHz	-156.5 [dBm/Hz]	3.5 GHz < frequency ≤ 4 GHz	-152.5 [dBm/Hz]	4 GHz < frequency ≤ 6 GHz	-152.5 [dBm/Hz]	6 GHz < frequency ≤ 13.5 GHz	-157.5 [dBm/Hz]	13.5 GHz < frequency ≤ 18.3 GHz	-155.5 [dBm/Hz]	18.3 GHz < frequency ≤ 26.5 GHz	-153.5 [dBm/Hz]	26.5 GHz < frequency ≤ 34 GHz	-153.5 [dBm/Hz]	34 GHz < frequency ≤ 40 GHz	-147.5 [dBm/Hz]	40 GHz < frequency ≤ 43 GHz	-144.5 [dBm/Hz]	300 MHz ≤ frequency < 1 GHz	-146.5 [dBm/Hz]	1 GHz ≤ frequency < 2.4 GHz	-143.5 [dBm/Hz]	2.4 GHz ≤ frequency ≤ 3.5 GHz	-140.5 [dBm/Hz]	3.5 GHz < frequency ≤ 4 GHz	-137.5 [dBm/Hz]	4 GHz < frequency ≤ 6 GHz	-137.5 [dBm/Hz]	300 MHz ≤ frequency < 1 GHz	-156.5 [dBm/Hz]	1 GHz ≤ frequency < 2 GHz	-154.5 [dBm/Hz]	2 GHz ≤ frequency ≤ 3.5 GHz	-152.5 [dBm/Hz]	3.5 GHz < frequency ≤ 4 GHz	-148.5 [dBm/Hz]	4 GHz < frequency ≤ 6 GHz	-148.5 [dBm/Hz]	6 GHz ≤ frequency ≤ 13.5 GHz	-137.5 [dBm/Hz]	13.5 GHz < frequency ≤ 18.3 GHz	-135.5 [dBm/Hz]	18.3 GHz < frequency ≤ 26.5 GHz	-131.5 [dBm/Hz]	26.5 GHz < frequency ≤ 34 GHz	-131.5 [dBm/Hz]	34 GHz < frequency ≤ 40 GHz	-125.5 [dBm/Hz]	40 GHz < frequency ≤ 43 GHz	-122.5 [dBm/Hz]
100 kHz	-144.5 [dBm/Hz] Nominal																																																										
1 MHz	-153.5 [dBm/Hz]																																																										
30 MHz ≤ frequency < 1 GHz	-160.5 [dBm/Hz]																																																										
1 GHz ≤ frequency < 2.4 GHz	-158.5 [dBm/Hz]																																																										
2.4 GHz ≤ frequency ≤ 3.5 GHz	-156.5 [dBm/Hz]																																																										
3.5 GHz < frequency ≤ 4 GHz	-152.5 [dBm/Hz]																																																										
4 GHz < frequency ≤ 6 GHz	-152.5 [dBm/Hz]																																																										
6 GHz < frequency ≤ 13.5 GHz	-157.5 [dBm/Hz]																																																										
13.5 GHz < frequency ≤ 18.3 GHz	-155.5 [dBm/Hz]																																																										
18.3 GHz < frequency ≤ 26.5 GHz	-153.5 [dBm/Hz]																																																										
26.5 GHz < frequency ≤ 34 GHz	-153.5 [dBm/Hz]																																																										
34 GHz < frequency ≤ 40 GHz	-147.5 [dBm/Hz]																																																										
40 GHz < frequency ≤ 43 GHz	-144.5 [dBm/Hz]																																																										
300 MHz ≤ frequency < 1 GHz	-146.5 [dBm/Hz]																																																										
1 GHz ≤ frequency < 2.4 GHz	-143.5 [dBm/Hz]																																																										
2.4 GHz ≤ frequency ≤ 3.5 GHz	-140.5 [dBm/Hz]																																																										
3.5 GHz < frequency ≤ 4 GHz	-137.5 [dBm/Hz]																																																										
4 GHz < frequency ≤ 6 GHz	-137.5 [dBm/Hz]																																																										
300 MHz ≤ frequency < 1 GHz	-156.5 [dBm/Hz]																																																										
1 GHz ≤ frequency < 2 GHz	-154.5 [dBm/Hz]																																																										
2 GHz ≤ frequency ≤ 3.5 GHz	-152.5 [dBm/Hz]																																																										
3.5 GHz < frequency ≤ 4 GHz	-148.5 [dBm/Hz]																																																										
4 GHz < frequency ≤ 6 GHz	-148.5 [dBm/Hz]																																																										
6 GHz ≤ frequency ≤ 13.5 GHz	-137.5 [dBm/Hz]																																																										
13.5 GHz < frequency ≤ 18.3 GHz	-135.5 [dBm/Hz]																																																										
18.3 GHz < frequency ≤ 26.5 GHz	-131.5 [dBm/Hz]																																																										
26.5 GHz < frequency ≤ 34 GHz	-131.5 [dBm/Hz]																																																										
34 GHz < frequency ≤ 40 GHz	-125.5 [dBm/Hz]																																																										
40 GHz < frequency ≤ 43 GHz	-122.5 [dBm/Hz]																																																										

Table 1.3.1-2 Specifications for Signal Analyzer Function (Continued)

Item	Specification																								
Display average noise level (Continued)	<p>With MS2830A-068/168, and with Preamplifier turned off.</p> <p>At 18°C to 28°C, input attenuator = 0 dB,</p> <table data-bbox="571 521 1315 618"> <tr> <td>6 GHz ≤ frequency ≤ 13.5 GHz</td> <td>-132.5 [dBm/Hz]</td> </tr> <tr> <td>13.5 GHz < frequency ≤ 18.3 GHz</td> <td>-130.5 [dBm/Hz]</td> </tr> <tr> <td>18.3 GHz < frequency ≤ 26.5 GHz</td> <td>-126.5 [dBm/Hz]</td> </tr> </table> <p>With MS2830A-045 Installed</p> <table data-bbox="571 651 1315 748"> <tr> <td>26.5 GHz < frequency ≤ 34 GHz</td> <td>-126.5 [dBm/Hz]</td> </tr> <tr> <td>34 GHz < frequency ≤ 40 GHz</td> <td>-121.5 [dBm/Hz]</td> </tr> <tr> <td>40 GHz < frequency ≤ 43 GHz</td> <td>-118.5 [dBm/Hz]</td> </tr> </table> <p>With MS2830A-068/168, and with Preamplifier turned on.</p> <p>At 18°C to 28°C, input attenuator = 0 dB,</p> <table data-bbox="571 819 1315 916"> <tr> <td>6 GHz ≤ frequency ≤ 13.5 GHz</td> <td>-147.5 [dBm/Hz]</td> </tr> <tr> <td>13.5 GHz < frequency ≤ 18.3 GHz</td> <td>-145.5 [dBm/Hz]</td> </tr> <tr> <td>18.3 GHz < frequency ≤ 26.5 GHz</td> <td>-143.5 [dBm/Hz]</td> </tr> </table> <p>With MS2830A-045 Installed</p> <table data-bbox="571 949 1315 1046"> <tr> <td>26.5 GHz < frequency ≤ 34 GHz</td> <td>-143.5 [dBm/Hz]</td> </tr> <tr> <td>34 GHz < frequency ≤ 40 GHz</td> <td>-137.5 [dBm/Hz]</td> </tr> <tr> <td>40 GHz < frequency ≤ 43 GHz</td> <td>-134.5 [dBm/Hz]</td> </tr> </table>	6 GHz ≤ frequency ≤ 13.5 GHz	-132.5 [dBm/Hz]	13.5 GHz < frequency ≤ 18.3 GHz	-130.5 [dBm/Hz]	18.3 GHz < frequency ≤ 26.5 GHz	-126.5 [dBm/Hz]	26.5 GHz < frequency ≤ 34 GHz	-126.5 [dBm/Hz]	34 GHz < frequency ≤ 40 GHz	-121.5 [dBm/Hz]	40 GHz < frequency ≤ 43 GHz	-118.5 [dBm/Hz]	6 GHz ≤ frequency ≤ 13.5 GHz	-147.5 [dBm/Hz]	13.5 GHz < frequency ≤ 18.3 GHz	-145.5 [dBm/Hz]	18.3 GHz < frequency ≤ 26.5 GHz	-143.5 [dBm/Hz]	26.5 GHz < frequency ≤ 34 GHz	-143.5 [dBm/Hz]	34 GHz < frequency ≤ 40 GHz	-137.5 [dBm/Hz]	40 GHz < frequency ≤ 43 GHz	-134.5 [dBm/Hz]
6 GHz ≤ frequency ≤ 13.5 GHz	-132.5 [dBm/Hz]																								
13.5 GHz < frequency ≤ 18.3 GHz	-130.5 [dBm/Hz]																								
18.3 GHz < frequency ≤ 26.5 GHz	-126.5 [dBm/Hz]																								
26.5 GHz < frequency ≤ 34 GHz	-126.5 [dBm/Hz]																								
34 GHz < frequency ≤ 40 GHz	-121.5 [dBm/Hz]																								
40 GHz < frequency ≤ 43 GHz	-118.5 [dBm/Hz]																								
6 GHz ≤ frequency ≤ 13.5 GHz	-147.5 [dBm/Hz]																								
13.5 GHz < frequency ≤ 18.3 GHz	-145.5 [dBm/Hz]																								
18.3 GHz < frequency ≤ 26.5 GHz	-143.5 [dBm/Hz]																								
26.5 GHz < frequency ≤ 34 GHz	-143.5 [dBm/Hz]																								
34 GHz < frequency ≤ 40 GHz	-137.5 [dBm/Hz]																								
40 GHz < frequency ≤ 43 GHz	-134.5 [dBm/Hz]																								

Table 1.3.1-2 Specifications for Signal Analyzer Function (Continued)

Item	Specification
Measurement function	
Adjacent Channel Power Measurement (ACP) Reference Adjacent channel specification	Span Total, Carrier Total, Both Sides of Carriers or Carrier Select 3 channels × 2
Channel Power Absolute value measurement	dBm, dBm/Hz
Occupied Bandwidth (OBW)	N% of Power method, X dB Down method
Power vs Time Display Function	
Function overview	Indicates time changes of power for captured waveform data
Analysis time range Analysis Start Time Analysis Time Length Setting mode	Sets analysis start time position from beginning of waveform data Sets analysis time span Auto, Manual
Resolution bandwidth Filter type Roll-off rate setting Filter frequency offset	Rect, Gaussian, Nyquist, Root Nyquist, Off (default: Off) 0.01 to 1 (settable for Nyquist and Root Nyquist) Filter center frequency can be set within frequency band of waveform data
Peak to Peak measurement	Measured using AM Depth or marker function +Peak, -Peak, (P-P)/2, Average
Burst Average Power	Measures average power of burst signal

Table 1.3.1-2 Specifications for Signal Analyzer Function (Continued)

Item	Specification
Frequency vs Time Display Function	
Function overview	Displays frequency time fluctuations of input signal from captured waveform data
Analysis time range Analysis Start Time Analysis Time Length Setting mode	Sets analysis start time position from beginning of waveform data Sets analysis time span Auto, Manual
Operating level range	-17 to +30 dBm (Input attenuator \geq 10 dB)
Frequency (vertical axis) Display frequency range Input frequency range	Center frequency and SPAN can be set within the frequency range in waveform data Selectable from 1/25, 1/10, 1/5 and 1/2 of analysis bandwidth 10 MHz to 6 GHz
Display frequency accuracy	Input level = -17 to +30 dBm, SPAN \leq 31.25 MHz, scale = SPAN/25, At CW input \pm (reference oscillator accuracy \times center frequency + indicator frequency range \times 0.01) Hz
Peak to Peak measurement	Measured using FM Depth or marker function +Peak, -Peak, (P-P)/2, Average
CCDF Display Function	
Function overview	Displays CCDF and APD of waveform data captured at specific time
Analysis time range Analysis Start Time Analysis Time Length Setting mode	Sets analysis start time position from beginning of waveform data Sets analysis time span Auto, Manual
Display Histogram resolution Numerical value	Graphically displays CCDF and APD 0.01 dB Average Power, Max Power, Crest Factor
Resolution Bandwidth Filter type Filter frequency offset	Rectangle, Off (default: Off) Filter center frequency can be set within frequency band of waveform data

Table 1.3.1-2 Specifications for Signal Analyzer Function (Continued)

Item	Specification
Spectrogram Display Function	
Function overview	Displays the spectrum for selected time length in the acquired waveform data.
Analysis time range Analysis Start Time Analysis Time Length Setting mode	Sets analysis start time position from beginning of waveform data Sets analysis time span Auto, Manual
Frequency	Center frequency and SPAN can be set within the frequency range in waveform data
Resolution bandwidth (RBW) Setting range Selectivity	1 Hz to 1 MHz (1-3 sequence) (-60 dB/-3 dB) 4.5:1, Nominal value
Digitize function	
Function overview	Capable of outputting captured waveform data to internal hard disk or external device
Waveform data Format Level Level accuracy	I, Q (32-bit Float Binary format) $\sqrt{I^2 + Q^2} = 1$ at 0 dBm input Same as absolute amplitude accuracy of signal analyzer
External output	Capable of outputting to external PC through Ethernet
Replay Function	
Function overview	Analyzes traces of saved waveform data
Conditions for measurable waveform data	I, Q (Binary format)

Table 1.3.1-2 Specifications for Signal Analyzer Function (Continued)

Item	Specification	
Conditions for measurable waveform data	SPAN	Sampling rate
	1 kHz	2 kHz
	2.5 kHz	5 kHz
	5 kHz	10 kHz
	10 kHz	25 kHz
	25 kHz	50 kHz
	50 kHz	100 kHz
	100 kHz	200 kHz
	250 kHz	500 kHz
	500 kHz	1 MHz
	1 MHz	2 MHz
	2.5 MHz	5 MHz
	5 MHz	10 MHz
	10 MHz	20 MHz
	18.6 MHz	20 MHz
	20 MHz	25 MHz
	25 MHz	50 MHz
	31.25 MHz	50 MHz
	50 MHz	100 MHz
	62.5 MHz	100 MHz
	100 MHz	200 MHz
	125 MHz	200 MHz

Table 1.3.1-2 Specifications for Signal Analyzer Function (Continued)

Item	Specification																																												
Combinations of SPAN and minimum capture sample	<table border="0"> <thead> <tr> <th data-bbox="539 488 746 517">SPAN</th> <th data-bbox="762 488 1091 517">Minimum Capture Sample</th> </tr> </thead> <tbody> <tr><td data-bbox="539 524 639 553">1 kHz</td><td data-bbox="762 524 943 553">74000 (37 s)</td></tr> <tr><td data-bbox="539 557 639 586">2.5 kHz</td><td data-bbox="762 557 943 586">160000 (32 s)</td></tr> <tr><td data-bbox="539 591 639 620">5 kHz</td><td data-bbox="762 591 943 620">310000 (31 s)</td></tr> <tr><td data-bbox="539 624 639 654">10 kHz</td><td data-bbox="762 624 963 654">610000 (30.5 s)</td></tr> <tr><td data-bbox="539 658 639 687">25 kHz</td><td data-bbox="762 658 963 687">730000 (14.6 s)</td></tr> <tr><td data-bbox="539 692 639 721">50 kHz</td><td data-bbox="762 692 963 721">730000 (7.3 s)</td></tr> <tr><td data-bbox="539 725 639 754">100 kHz</td><td data-bbox="762 725 963 754">730000 (3.65 s)</td></tr> <tr><td data-bbox="539 759 639 788">250 kHz</td><td data-bbox="762 759 963 788">730000 (1.46 s)</td></tr> <tr><td data-bbox="539 792 639 822">500 kHz</td><td data-bbox="762 792 963 822">730000 (730 ms)</td></tr> <tr><td data-bbox="539 826 639 855">1 MHz</td><td data-bbox="762 826 963 855">730000 (365 ms)</td></tr> <tr><td data-bbox="539 860 639 889">2.5 MHz</td><td data-bbox="762 860 963 889">730000 (146 ms)</td></tr> <tr><td data-bbox="539 893 639 922">5 MHz</td><td data-bbox="762 893 963 922">730000 (73 ms)</td></tr> <tr><td data-bbox="539 927 639 956">10 MHz</td><td data-bbox="762 927 963 956">730000 (36.5 ms)</td></tr> <tr><td data-bbox="539 960 639 990">18.6 MHz</td><td data-bbox="762 960 963 990">730000 (36.5 ms)</td></tr> <tr><td data-bbox="539 994 639 1023">20 MHz</td><td data-bbox="762 994 963 1023">730000 (29.2 ms)</td></tr> <tr><td data-bbox="539 1028 639 1057">25 MHz</td><td data-bbox="762 1028 963 1057">730000 (14.6 ms)</td></tr> <tr><td data-bbox="539 1061 639 1090">31.25 MHz</td><td data-bbox="762 1061 963 1090">730000 (14.6 ms)</td></tr> <tr><td data-bbox="539 1095 639 1124">50 MHz</td><td data-bbox="762 1095 963 1124">730000 (7.3 ms)</td></tr> <tr><td data-bbox="539 1128 639 1158">62.5 MHz</td><td data-bbox="762 1128 963 1158">730000 (7.3 ms)</td></tr> <tr><td data-bbox="539 1162 639 1191">100 MHz</td><td data-bbox="762 1162 963 1191">730000 (3.65 ms)</td></tr> <tr><td data-bbox="539 1196 639 1225">125 MHz</td><td data-bbox="762 1196 963 1225">730000 (3.65 ms)</td></tr> </tbody> </table>	SPAN	Minimum Capture Sample	1 kHz	74000 (37 s)	2.5 kHz	160000 (32 s)	5 kHz	310000 (31 s)	10 kHz	610000 (30.5 s)	25 kHz	730000 (14.6 s)	50 kHz	730000 (7.3 s)	100 kHz	730000 (3.65 s)	250 kHz	730000 (1.46 s)	500 kHz	730000 (730 ms)	1 MHz	730000 (365 ms)	2.5 MHz	730000 (146 ms)	5 MHz	730000 (73 ms)	10 MHz	730000 (36.5 ms)	18.6 MHz	730000 (36.5 ms)	20 MHz	730000 (29.2 ms)	25 MHz	730000 (14.6 ms)	31.25 MHz	730000 (14.6 ms)	50 MHz	730000 (7.3 ms)	62.5 MHz	730000 (7.3 ms)	100 MHz	730000 (3.65 ms)	125 MHz	730000 (3.65 ms)
SPAN	Minimum Capture Sample																																												
1 kHz	74000 (37 s)																																												
2.5 kHz	160000 (32 s)																																												
5 kHz	310000 (31 s)																																												
10 kHz	610000 (30.5 s)																																												
25 kHz	730000 (14.6 s)																																												
50 kHz	730000 (7.3 s)																																												
100 kHz	730000 (3.65 s)																																												
250 kHz	730000 (1.46 s)																																												
500 kHz	730000 (730 ms)																																												
1 MHz	730000 (365 ms)																																												
2.5 MHz	730000 (146 ms)																																												
5 MHz	730000 (73 ms)																																												
10 MHz	730000 (36.5 ms)																																												
18.6 MHz	730000 (36.5 ms)																																												
20 MHz	730000 (29.2 ms)																																												
25 MHz	730000 (14.6 ms)																																												
31.25 MHz	730000 (14.6 ms)																																												
50 MHz	730000 (7.3 ms)																																												
62.5 MHz	730000 (7.3 ms)																																												
100 MHz	730000 (3.65 ms)																																												
125 MHz	730000 (3.65 ms)																																												
Phase vs Time																																													
Function overview	Displays the phase time fluctuation of the input signal in the acquired waveform data.																																												
Analysis Time Range Available Mode Analysis Start Time Analysis Time Length	Auto, Manual Sets analysis start time position from beginning of waveform data. Sets analysis time span.																																												
Phase (Vertical Axis) Display Mode Phase Display Range Offset	Wrap, Unwrap 0.01 deg./div to 200 Gdeg./div -100 to 100 Mdeg.																																												

Table 1.3.1-3 Specifications for spectrum analyzer function

Item	Specification
Frequency	
SPAN	
Range	0 Hz, 300 Hz to 3.6 GHz (MS2830A-040) 0 Hz, 300 Hz to 6 GHz (MS2830A-041) 0 Hz, 300 Hz to 13.5 GHz (MS2830A-043) 0 Hz, 300 Hz to 1 MHz (MS2830A-062/066) 0 Hz, 300 Hz to 26.5 GHz (MS2830A-044) 0 Hz, 300 Hz to 43 GHz (MS2830A-045)
Resolution	2 Hz
SPAN accuracy	±0.2% When number of trace points = 10001
Display frequency accuracy	±[Indicator frequency × reference frequency accuracy + SPAN frequency × SPAN accuracy + RBW × 0.05 + 2 × N + SPAN frequency / (Trace point count - 1)] Hz N is Mixing order
Resolution bandwidth (RBW)	
Settable range	1 Hz to 3 MHz (1-3 sequence), 50 kHz, 5 MHz, 10 MHz, 20 MHz, 31.25 MHz 1 Hz to 10 Hz: Not available when SPAN = 0 Hz 31.25 MHz: Available when SPAN = 0 Hz 20 MHz and 31.25 MHz: Available only when MS2830A-005/105 or MS2830A-007 is installed With MS2830A-062/066 installed, and Option 062/066 enabled, 1 Hz to 100 kHz
Selectivity	(-60 dB/-3 dB) 4.5:1, Nominal value, when 1 Hz to 10 MHz is set.
Video bandwidth (VBW)	
Setting range	1 Hz to 10 MHz (1-3 sequence), 5 kHz, off
VBW mode	Video Average/Power Average

Table 1.3.1-3 Specifications for spectrum analyzer function (Continued)

Item	Specification																														
Amplitude																															
Display average noise level	<p>At 18 to 28°C, Detector = Sample, VBW = 1 Hz (Video Average), Input attenuator 0 dB,</p> <p>With MS2830A-040/041/043, Without MS2830A-062/066, Without MS2830A-008/108 or with Preamplifier turned off:</p> <table border="0"> <tr> <td>100 kHz</td> <td>-134 [dBm/Hz]</td> </tr> <tr> <td>1 MHz</td> <td>-144 [dBm/Hz]</td> </tr> <tr> <td>30 MHz≤frequency<1 GHz</td> <td>-153 [dBm/Hz]</td> </tr> <tr> <td>1 GHz≤frequency<2.4 GHz</td> <td>-151 [dBm/Hz]</td> </tr> <tr> <td>2.4 GHz≤frequency≤3.5 GHz</td> <td>-149 [dBm/Hz]</td> </tr> </table> <p>With MS2830A-041/043 3.5 GHz<frequency≤6 GHz -146 [dBm/Hz]</p> <p>With MS2830A-043 6 GHz<frequency≤13.5 GHz -142 [dBm/Hz]</p> <p>Without MS2830A-062/066, With MS2830A-008/108 and with Preamplifier turned on</p> <table border="0"> <tr> <td>100 kHz</td> <td>-147 [dBm/Hz] Nominal</td> </tr> <tr> <td>1 MHz</td> <td>-156 [dBm/Hz]</td> </tr> <tr> <td>30 MHz≤frequency<1 GHz</td> <td>-163 [dBm/Hz]</td> </tr> <tr> <td>1 GHz≤frequency<2 GHz</td> <td>-162 [dBm/Hz]</td> </tr> <tr> <td>2 GHz≤frequency≤3.5 GHz</td> <td>-160 [dBm/Hz]</td> </tr> </table> <p>With MS2830A-041/043, Frequency Band Mode: Normal 3.5 GHz<frequency≤4 GHz -157 [dBm/Hz]</p> <p>With MS2830A-041/043, Frequency Band Mode: Spurious 3.5 GHz<frequency≤4 GHz -157 [dBm/Hz]</p> <p>With MS2830A-041/043, 4 GHz<frequency≤6 GHz -157 [dBm/Hz]</p> <p>With MS2830A-062/066 installed, Without MS2830A-008/108 or with Preamplifier turned off:</p> <table border="0"> <tr> <td>100 kHz</td> <td>-133 [dBm/Hz]</td> </tr> <tr> <td>1 MHz</td> <td>-143 [dBm/Hz]</td> </tr> <tr> <td>30 MHz≤frequency<1 GHz</td> <td>-152 [dBm/Hz]</td> </tr> <tr> <td>1 GHz≤frequency<2.4 GHz</td> <td>-150 [dBm/Hz]</td> </tr> <tr> <td>2.4 GHz≤frequency≤3.5 GHz</td> <td>-147 [dBm/Hz]</td> </tr> </table> <p>With MS2830A-041/043 installed, 3.5 GHz<frequency≤6 GHz -144 [dBm/Hz]</p> <p>With MS2830A-043 installed, 6 GHz<frequency≤13.5 GHz -142 [dBm/Hz]</p>	100 kHz	-134 [dBm/Hz]	1 MHz	-144 [dBm/Hz]	30 MHz≤frequency<1 GHz	-153 [dBm/Hz]	1 GHz≤frequency<2.4 GHz	-151 [dBm/Hz]	2.4 GHz≤frequency≤3.5 GHz	-149 [dBm/Hz]	100 kHz	-147 [dBm/Hz] Nominal	1 MHz	-156 [dBm/Hz]	30 MHz≤frequency<1 GHz	-163 [dBm/Hz]	1 GHz≤frequency<2 GHz	-162 [dBm/Hz]	2 GHz≤frequency≤3.5 GHz	-160 [dBm/Hz]	100 kHz	-133 [dBm/Hz]	1 MHz	-143 [dBm/Hz]	30 MHz≤frequency<1 GHz	-152 [dBm/Hz]	1 GHz≤frequency<2.4 GHz	-150 [dBm/Hz]	2.4 GHz≤frequency≤3.5 GHz	-147 [dBm/Hz]
100 kHz	-134 [dBm/Hz]																														
1 MHz	-144 [dBm/Hz]																														
30 MHz≤frequency<1 GHz	-153 [dBm/Hz]																														
1 GHz≤frequency<2.4 GHz	-151 [dBm/Hz]																														
2.4 GHz≤frequency≤3.5 GHz	-149 [dBm/Hz]																														
100 kHz	-147 [dBm/Hz] Nominal																														
1 MHz	-156 [dBm/Hz]																														
30 MHz≤frequency<1 GHz	-163 [dBm/Hz]																														
1 GHz≤frequency<2 GHz	-162 [dBm/Hz]																														
2 GHz≤frequency≤3.5 GHz	-160 [dBm/Hz]																														
100 kHz	-133 [dBm/Hz]																														
1 MHz	-143 [dBm/Hz]																														
30 MHz≤frequency<1 GHz	-152 [dBm/Hz]																														
1 GHz≤frequency<2.4 GHz	-150 [dBm/Hz]																														
2.4 GHz≤frequency≤3.5 GHz	-147 [dBm/Hz]																														

Table 1.3.1-3 Specifications for spectrum analyzer function (Continued)

Item	Specification																																																																				
Display average noise level (Continued)	<p>With MS2830A-062/066 installed, With MS2830A-008/108 and with Preamplifier turned on:</p> <table border="0"> <tr> <td>100 kHz</td> <td>-146 [dBm/Hz] Nominal</td> </tr> <tr> <td>1 MHz</td> <td>-155 [dBm/Hz]</td> </tr> <tr> <td>30 MHz ≤ Frequency < 1 GHz</td> <td>-162 [dBm/Hz]</td> </tr> <tr> <td>1 GHz ≤ Frequency < 2 GHz</td> <td>-161 [dBm/Hz]</td> </tr> <tr> <td>2 GHz ≤ Frequency ≤ 3.5 GHz</td> <td>-158 [dBm/Hz]</td> </tr> </table> <p>With MS2830A-041/043 installed, Frequency Band Mode: Normal</p> <table border="0"> <tr> <td>3.5 GHz < Frequency ≤ 4 GHz</td> <td>-154 [dBm/Hz]</td> </tr> </table> <p>With MS2830A-041/043 installed, Frequency Band Mode: Spurious</p> <table border="0"> <tr> <td>3.5 GHz < Frequency ≤ 4 GHz</td> <td>-154 [dBm/Hz]</td> </tr> </table> <p>With MS2830A-041/043 installed,</p> <table border="0"> <tr> <td>4 GHz < Frequency ≤ 6 GHz</td> <td>-154 [dBm/Hz]</td> </tr> </table> <p>With MS2830A-044/045 installed, Without MS2830A-067/167/068/168, Frequency Band Mode: Normal</p> <table border="0"> <tr> <td>100 kHz</td> <td>-134 [dBm/Hz]</td> </tr> <tr> <td>1 MHz</td> <td>-144 [dBm/Hz]</td> </tr> <tr> <td>30 MHz ≤ frequency < 1 GHz</td> <td>-153 [dBm/Hz]</td> </tr> <tr> <td>1 GHz ≤ frequency < 2.4 GHz</td> <td>-150 [dBm/Hz]</td> </tr> <tr> <td>2.4 GHz ≤ frequency ≤ 3.5 GHz</td> <td>-147 [dBm/Hz]</td> </tr> <tr> <td>3.5 GHz < frequency ≤ 4 GHz</td> <td>-144 [dBm/Hz]</td> </tr> <tr> <td>4 GHz < frequency ≤ 6 GHz</td> <td>-144 [dBm/Hz]</td> </tr> <tr> <td>6 GHz < frequency ≤ 13.5 GHz</td> <td>-151 [dBm/Hz]</td> </tr> <tr> <td>13.5 GHz < frequency ≤ 18.3 GHz</td> <td>-149 [dBm/Hz]</td> </tr> <tr> <td>18.3 GHz < frequency ≤ 26.5 GHz</td> <td>-146 [dBm/Hz]</td> </tr> </table> <p>With MS2830A-045,</p> <table border="0"> <tr> <td>26.5 GHz < frequency ≤ 34 GHz</td> <td>-146 [dBm/Hz]</td> </tr> <tr> <td>34 GHz < frequency ≤ 40 GHz</td> <td>-144 [dBm/Hz]</td> </tr> <tr> <td>40 GHz < frequency ≤ 43 GHz</td> <td>-140 [dBm/Hz]</td> </tr> </table> <p>Without MS2830A-067/167 and with MS2830A-068/168, and with Preamplifier turned off, at Frequency Band Mode: Normal</p> <table border="0"> <tr> <td>100 kHz</td> <td>-134 [dBm/Hz]</td> </tr> <tr> <td>1 MHz</td> <td>-144 [dBm/Hz]</td> </tr> <tr> <td>30 MHz ≤ frequency < 1 GHz</td> <td>-153 [dBm/Hz]</td> </tr> <tr> <td>1 GHz ≤ frequency < 2.4 GHz</td> <td>-150 [dBm/Hz]</td> </tr> <tr> <td>2.4 GHz ≤ frequency ≤ 3.5 GHz</td> <td>-147 [dBm/Hz]</td> </tr> <tr> <td>3.5 GHz < frequency ≤ 4 GHz</td> <td>-144 [dBm/Hz]</td> </tr> <tr> <td>4 GHz < frequency ≤ 6 GHz</td> <td>-144 [dBm/Hz]</td> </tr> <tr> <td>6 GHz < frequency ≤ 13.5 GHz</td> <td>-147 [dBm/Hz]</td> </tr> <tr> <td>13.5 GHz < frequency ≤ 18.3 GHz</td> <td>-145 [dBm/Hz]</td> </tr> <tr> <td>18.3 GHz < frequency ≤ 26.5 GHz</td> <td>-141 [dBm/Hz]</td> </tr> </table> <p>With MS2830A-045,</p> <table border="0"> <tr> <td>26.5 GHz < frequency ≤ 34 GHz</td> <td>-141 [dBm/Hz]</td> </tr> <tr> <td>34 GHz < frequency ≤ 40 GHz</td> <td>-135 [dBm/Hz]</td> </tr> <tr> <td>40 GHz < frequency ≤ 43 GHz</td> <td>-132 [dBm/Hz]</td> </tr> </table>	100 kHz	-146 [dBm/Hz] Nominal	1 MHz	-155 [dBm/Hz]	30 MHz ≤ Frequency < 1 GHz	-162 [dBm/Hz]	1 GHz ≤ Frequency < 2 GHz	-161 [dBm/Hz]	2 GHz ≤ Frequency ≤ 3.5 GHz	-158 [dBm/Hz]	3.5 GHz < Frequency ≤ 4 GHz	-154 [dBm/Hz]	3.5 GHz < Frequency ≤ 4 GHz	-154 [dBm/Hz]	4 GHz < Frequency ≤ 6 GHz	-154 [dBm/Hz]	100 kHz	-134 [dBm/Hz]	1 MHz	-144 [dBm/Hz]	30 MHz ≤ frequency < 1 GHz	-153 [dBm/Hz]	1 GHz ≤ frequency < 2.4 GHz	-150 [dBm/Hz]	2.4 GHz ≤ frequency ≤ 3.5 GHz	-147 [dBm/Hz]	3.5 GHz < frequency ≤ 4 GHz	-144 [dBm/Hz]	4 GHz < frequency ≤ 6 GHz	-144 [dBm/Hz]	6 GHz < frequency ≤ 13.5 GHz	-151 [dBm/Hz]	13.5 GHz < frequency ≤ 18.3 GHz	-149 [dBm/Hz]	18.3 GHz < frequency ≤ 26.5 GHz	-146 [dBm/Hz]	26.5 GHz < frequency ≤ 34 GHz	-146 [dBm/Hz]	34 GHz < frequency ≤ 40 GHz	-144 [dBm/Hz]	40 GHz < frequency ≤ 43 GHz	-140 [dBm/Hz]	100 kHz	-134 [dBm/Hz]	1 MHz	-144 [dBm/Hz]	30 MHz ≤ frequency < 1 GHz	-153 [dBm/Hz]	1 GHz ≤ frequency < 2.4 GHz	-150 [dBm/Hz]	2.4 GHz ≤ frequency ≤ 3.5 GHz	-147 [dBm/Hz]	3.5 GHz < frequency ≤ 4 GHz	-144 [dBm/Hz]	4 GHz < frequency ≤ 6 GHz	-144 [dBm/Hz]	6 GHz < frequency ≤ 13.5 GHz	-147 [dBm/Hz]	13.5 GHz < frequency ≤ 18.3 GHz	-145 [dBm/Hz]	18.3 GHz < frequency ≤ 26.5 GHz	-141 [dBm/Hz]	26.5 GHz < frequency ≤ 34 GHz	-141 [dBm/Hz]	34 GHz < frequency ≤ 40 GHz	-135 [dBm/Hz]	40 GHz < frequency ≤ 43 GHz	-132 [dBm/Hz]
100 kHz	-146 [dBm/Hz] Nominal																																																																				
1 MHz	-155 [dBm/Hz]																																																																				
30 MHz ≤ Frequency < 1 GHz	-162 [dBm/Hz]																																																																				
1 GHz ≤ Frequency < 2 GHz	-161 [dBm/Hz]																																																																				
2 GHz ≤ Frequency ≤ 3.5 GHz	-158 [dBm/Hz]																																																																				
3.5 GHz < Frequency ≤ 4 GHz	-154 [dBm/Hz]																																																																				
3.5 GHz < Frequency ≤ 4 GHz	-154 [dBm/Hz]																																																																				
4 GHz < Frequency ≤ 6 GHz	-154 [dBm/Hz]																																																																				
100 kHz	-134 [dBm/Hz]																																																																				
1 MHz	-144 [dBm/Hz]																																																																				
30 MHz ≤ frequency < 1 GHz	-153 [dBm/Hz]																																																																				
1 GHz ≤ frequency < 2.4 GHz	-150 [dBm/Hz]																																																																				
2.4 GHz ≤ frequency ≤ 3.5 GHz	-147 [dBm/Hz]																																																																				
3.5 GHz < frequency ≤ 4 GHz	-144 [dBm/Hz]																																																																				
4 GHz < frequency ≤ 6 GHz	-144 [dBm/Hz]																																																																				
6 GHz < frequency ≤ 13.5 GHz	-151 [dBm/Hz]																																																																				
13.5 GHz < frequency ≤ 18.3 GHz	-149 [dBm/Hz]																																																																				
18.3 GHz < frequency ≤ 26.5 GHz	-146 [dBm/Hz]																																																																				
26.5 GHz < frequency ≤ 34 GHz	-146 [dBm/Hz]																																																																				
34 GHz < frequency ≤ 40 GHz	-144 [dBm/Hz]																																																																				
40 GHz < frequency ≤ 43 GHz	-140 [dBm/Hz]																																																																				
100 kHz	-134 [dBm/Hz]																																																																				
1 MHz	-144 [dBm/Hz]																																																																				
30 MHz ≤ frequency < 1 GHz	-153 [dBm/Hz]																																																																				
1 GHz ≤ frequency < 2.4 GHz	-150 [dBm/Hz]																																																																				
2.4 GHz ≤ frequency ≤ 3.5 GHz	-147 [dBm/Hz]																																																																				
3.5 GHz < frequency ≤ 4 GHz	-144 [dBm/Hz]																																																																				
4 GHz < frequency ≤ 6 GHz	-144 [dBm/Hz]																																																																				
6 GHz < frequency ≤ 13.5 GHz	-147 [dBm/Hz]																																																																				
13.5 GHz < frequency ≤ 18.3 GHz	-145 [dBm/Hz]																																																																				
18.3 GHz < frequency ≤ 26.5 GHz	-141 [dBm/Hz]																																																																				
26.5 GHz < frequency ≤ 34 GHz	-141 [dBm/Hz]																																																																				
34 GHz < frequency ≤ 40 GHz	-135 [dBm/Hz]																																																																				
40 GHz < frequency ≤ 43 GHz	-132 [dBm/Hz]																																																																				

Table 1.3.1-3 Specifications for spectrum analyzer function (Continued)

Item	Specification																										
Display average noise level (Continued)	Without MS2830A-067/167 or with Microwave Preselector Bypass turned off, and with MS2830A-068/168 and with Preamplifier turned on, at Frequency Band Mode: Normal <table style="margin-left: 20px;"> <tr> <td>100 kHz</td> <td>-147 [dBm/Hz] Nominal</td> </tr> <tr> <td>1 MHz</td> <td>-156 [dBm/Hz]</td> </tr> <tr> <td>30 MHz ≤ frequency < 1 GHz</td> <td>-163 [dBm/Hz]</td> </tr> <tr> <td>1 GHz ≤ frequency < 2 GHz</td> <td>-161 [dBm/Hz]</td> </tr> <tr> <td>2 GHz ≤ frequency ≤ 3.5 GHz</td> <td>-159 [dBm/Hz]</td> </tr> <tr> <td>3.5 GHz < frequency ≤ 4 GHz</td> <td>-155 [dBm/Hz]</td> </tr> <tr> <td>4 GHz < frequency ≤ 6 GHz</td> <td>-155 [dBm/Hz]</td> </tr> <tr> <td>6 GHz < frequency ≤ 13.5 GHz</td> <td>-160 [dBm/Hz]</td> </tr> <tr> <td>13.5 GHz < frequency ≤ 18.3 GHz</td> <td>-158 [dBm/Hz]</td> </tr> <tr> <td>18.3 GHz < frequency ≤ 26.5 GHz</td> <td>-156 [dBm/Hz]</td> </tr> </table> With MS2830A-045, <table style="margin-left: 20px;"> <tr> <td>26.5 GHz < frequency ≤ 34 GHz</td> <td>-156 [dBm/Hz]</td> </tr> <tr> <td>34 GHz < frequency ≤ 40 GHz</td> <td>-150 [dBm/Hz]</td> </tr> <tr> <td>40 GHz < frequency ≤ 43 GHz</td> <td>-147 [dBm/Hz]</td> </tr> </table>	100 kHz	-147 [dBm/Hz] Nominal	1 MHz	-156 [dBm/Hz]	30 MHz ≤ frequency < 1 GHz	-163 [dBm/Hz]	1 GHz ≤ frequency < 2 GHz	-161 [dBm/Hz]	2 GHz ≤ frequency ≤ 3.5 GHz	-159 [dBm/Hz]	3.5 GHz < frequency ≤ 4 GHz	-155 [dBm/Hz]	4 GHz < frequency ≤ 6 GHz	-155 [dBm/Hz]	6 GHz < frequency ≤ 13.5 GHz	-160 [dBm/Hz]	13.5 GHz < frequency ≤ 18.3 GHz	-158 [dBm/Hz]	18.3 GHz < frequency ≤ 26.5 GHz	-156 [dBm/Hz]	26.5 GHz < frequency ≤ 34 GHz	-156 [dBm/Hz]	34 GHz < frequency ≤ 40 GHz	-150 [dBm/Hz]	40 GHz < frequency ≤ 43 GHz	-147 [dBm/Hz]
100 kHz	-147 [dBm/Hz] Nominal																										
1 MHz	-156 [dBm/Hz]																										
30 MHz ≤ frequency < 1 GHz	-163 [dBm/Hz]																										
1 GHz ≤ frequency < 2 GHz	-161 [dBm/Hz]																										
2 GHz ≤ frequency ≤ 3.5 GHz	-159 [dBm/Hz]																										
3.5 GHz < frequency ≤ 4 GHz	-155 [dBm/Hz]																										
4 GHz < frequency ≤ 6 GHz	-155 [dBm/Hz]																										
6 GHz < frequency ≤ 13.5 GHz	-160 [dBm/Hz]																										
13.5 GHz < frequency ≤ 18.3 GHz	-158 [dBm/Hz]																										
18.3 GHz < frequency ≤ 26.5 GHz	-156 [dBm/Hz]																										
26.5 GHz < frequency ≤ 34 GHz	-156 [dBm/Hz]																										
34 GHz < frequency ≤ 40 GHz	-150 [dBm/Hz]																										
40 GHz < frequency ≤ 43 GHz	-147 [dBm/Hz]																										
Absolute amplitude accuracy	After CAL execution at 18° to 28°C, Auto Sweep Time Select = Normal, 30 Hz ≤ RBW ≤ 1 MHz, Detection = Positive, CW, excluding the noise floor effect, and not when FFT is being executed (displayed on the screen). <p>With Preamplifier turned off:</p> <p style="margin-left: 20px;">Input attenuator ≥ 10 dB, Mixer input level ≤ -10 dBm</p> <p>With Preamplifier turned on:</p> <p style="margin-left: 20px;">Input attenuator = 10 dB, preamplifier input level ≤ -20 dBm,</p> <p>With MS2830A-040/041/043 installed,</p> <p style="margin-left: 20px;">Without MS2830A-008/108, or with Preamplifier turned off</p> <p style="margin-left: 40px;">±0.5 dB (300 kHz ≤ frequency < 4 GHz, Frequency Band Mode: Normal)</p> <p style="margin-left: 40px;">±1.8 dB (300 kHz ≤ frequency < 3.5 GHz, Frequency Band Mode: Spurious)</p> <p style="margin-left: 40px;">±1.8 dB (4 GHz ≤ frequency ≤ 6 GHz, Frequency Band Mode: Normal)</p> <p style="margin-left: 40px;">±1.8 dB (3.5 GHz ≤ frequency ≤ 6 GHz, Frequency Band Mode: Spurious)</p> <p style="margin-left: 40px;">±1.8 dB (6 GHz < frequency ≤ 13.5 GHz)</p> <p>With MS2830A-008/108 and with Preamplifier turned on</p> <p style="margin-left: 40px;">±1.0 dB (300 kHz ≤ frequency < 4 GHz, Frequency Band Mode: Normal)</p> <p style="margin-left: 40px;">±1.8 dB (300 kHz ≤ frequency < 3.5 GHz, Frequency Band Mode: Spurious)</p> <p style="margin-left: 40px;">±1.8 dB (4 GHz ≤ frequency ≤ 6 GHz, Frequency Band Mode: Normal)</p> <p style="margin-left: 40px;">±1.8 dB (3.5 GHz ≤ frequency ≤ 6 GHz, Frequency Band Mode: Spurious)</p>																										

Table 1.3.1-3 Specifications for spectrum analyzer function (Continued)

Item	Specification
Absolute amplitude accuracy (Continued)	<p>With MS2830A-044/045 installed, Without MS2830A-068/168 or with Preamplifier turned off:</p> <p>±0.5 dB (300 kHz ≤ frequency < 4 GHz, Frequency Band Mode: Normal) (300 kHz ≤ frequency < 3.5 GHz, Frequency Band Mode: Spurious)</p> <p>±1.8 dB (4 GHz ≤ frequency ≤ 6 GHz, Frequency Band Mode: Normal) (3.5 GHz ≤ frequency ≤ 4 GHz, Frequency Band Mode: Spurious)</p> <p>±1.8 dB (6 GHz < frequency ≤ 13.8 GHz, Frequency Band Mode: Normal) (4 GHz < frequency ≤ 13.8 GHz, Frequency Band Mode: Spurious)</p> <p>±3.0 dB (13.8 GHz < frequency ≤ 26.5 GHz)</p> <p>±3.0 dB (26.5 GHz < frequency ≤ 40 GHz)</p> <p>±3.5 dB Nominal (40 GHz < frequency ≤ 43 GHz)</p> <p>With MS2830A-068/168 and with Preamplifier turned on:</p> <p>±1.0 dB (300 kHz ≤ frequency < 4 GHz, Frequency Band Mode: Normal) (300 kHz ≤ frequency < 3.5 GHz, Frequency Band Mode: Spurious)</p> <p>±1.8 dB (4 GHz ≤ frequency ≤ 6 GHz, Frequency Band Mode: Normal) (3.5 GHz ≤ frequency ≤ 4 GHz, Frequency Band Mode: Spurious)</p> <p>±2.0 dB (6 GHz < frequency ≤ 13.8 GHz, Frequency Band Mode: Normal) (4 GHz < frequency ≤ 13.8 GHz, Frequency Band Mode: Spurious)</p> <p>±3.0 dB (13.8 GHz < frequency ≤ 26.5 GHz)</p> <p>±4.0 dB (26.5 GHz < frequency ≤ 40 GHz)</p> <p>±4.0 dB Nominal (40 GHz < frequency ≤ 43 GHz)</p> <p>The absolute amplitude accuracy is calculated from an RSS (root summed square) error of the RF frequency characteristics, linearity error and input attenuator switching error.</p>

Table 1.3.1-3 Specifications for spectrum analyzer function (Continued)

Item	Specification
Spurious Response	
Two-tone third-order intermodulation distortion	<p>With MS2830A-040/041/043</p> <p>Without MS2830A-008/108, or with Preamplifier turned off: At 18° to 28°C, with mixer input level = -15 dBm (per tone) and using ≥ 300 kHz separation, at RBW ≤30kHz:</p> <ul style="list-style-type: none"> ≤-54 dBc (TOI = +12 dBm) (30 MHz ≤ frequency < 300 MHz) ≤-60 dBc (TOI = +15 dBm) (300 MHz ≤ frequency < 3.5 GHz) ≤-58 dBc (TOI = +14 dBm) (3.5 GHz ≤ frequency ≤ 6 GHz) ≤-50 dBc (TOI = +10 dBm) (6 GHz ≤ frequency ≤ 13.5 GHz) <p>With MS2830A-008/108 installed and with Preamplifier turned on At 18° to 28°C, with Preamplifier input level = -45 dBm (per wave) and using ≥ 300 kHz separation, at RBW ≤30kHz:</p> <ul style="list-style-type: none"> ≤-73 dBc (TOI = -8.5 dBm) (30 MHz ≤ frequency < 300 MHz) ≤-78 dBc (TOI = -6 dBm) (300 MHz ≤ frequency ≤ 700 MHz) ≤-81 dBc (TOI = -4.5 dBm) (700 MHz ≤ frequency < 4 GHz, Frequency Band Mode: Normal) (700 MHz ≤ frequency < 3.5 GHz, Frequency Band Mode: Spurious) ≤-78 dBc (TOI = -6 dBm) (4 GHz ≤ frequency ≤ 6 GHz, Frequency Band Mode: Normal) (3.5 GHz ≤ frequency ≤ 6 GHz, Frequency Band Mode: Spurious) <p>With MS2830A-044/045 installed</p> <p>Without MS2830A-068/168 or with Preamplifier turned off, At 18°C to 28°C, with mixer input level = -15 dBm (per wave) and using ≥ 300 kHz separation, at RBW ≤30kHz:</p> <ul style="list-style-type: none"> ≤-54 dBc (TOI = +12 dBm) (30 MHz ≤ frequency < 300 MHz) ≤-60 dBc (TOI = +15 dBm) (300 MHz ≤ frequency < 3.5 GHz) ≤-58 dBc (TOI = +14 dBm) (3.5 GHz ≤ frequency ≤ 6 GHz, Frequency Band Mode: Normal) ≤-56 dBc (TOI = +13 dBm) (6 GHz < frequency ≤ 13.5 GHz) ≤-56 dBc (TOI = +13 dBm) (13.5 GHz < frequency ≤ 26.5 GHz) ≤-56 dBc (TOI = +13 dBm) Nominal (26.5 GHz < frequency ≤ 40 GHz) With MS2830A-045 installed

Table 1.3.1-3 Specifications for spectrum analyzer function (Continued)

Item	Specification
Two-tone third-order intermodulation distortion (Continued)	<p>With MS2830A-044/045 installed</p> <p>With MS2830A-067/167 and with Microwave Preselector Bypass turned off, and with MS2830A-068/168 and with Preamplifier turned on, At 18°C to 28°C, with Preamplifier input level = -45 dBm (per wave) and using ≥ 300 kHz separation, at RBW ≤ 30 kHz:</p> <ul style="list-style-type: none"> ≤ -73 dBc (TOI = -8.5 dBm) (30 MHz \leq frequency < 300 MHz) ≤ -78 dBc (TOI = -6 dBm) (300 MHz \leq frequency \leq 700 MHz) ≤ -81 dBc (TOI = -4.5 dBm) (700 MHz < frequency < 4 GHz, Frequency Band Mode: Normal) (700 MHz < frequency < 3.5 GHz, Frequency Band Mode: Spurious) ≤ -78 dBc (TOI = -6 dBm) (4 GHz \leq frequency \leq 6 GHz, Frequency Band Mode: Normal) (3.5 GHz \leq frequency \leq 4 GHz, Frequency Band Mode: Spurious) ≤ -70 dBc (TOI = -10 dBm) (6 GHz < frequency \leq 13.5 GHz, Frequency Band Mode: Normal) (4 GHz < frequency \leq 13.5 GHz, Frequency Band Mode: Spurious) ≤ -70 dBc (TOI = -10 dBm) (13.5 GHz < frequency \leq 26.5 GHz) ≤ -70 dBc (TOI = -10 dBm) Nominal (26.5 GHz < frequency \leq 40 GHz) With MS2830A-045 installed <p>When Attenuator Mode is E-ATT Combined: Without MS2830A-008/108/068/168 and with Preamplifier turned off, at 18° to 28°C , with mixer input level = -15dBm (per wave) and using ≥ 300 kHz separation, at RBW ≤ 30 kHz:</p> <ul style="list-style-type: none"> ≤ -54 dBc (TOI = +12 dBm) (30MHz \leq Frequency < 300MHz, RF input level ≤ -5 dBm) ≤ -60 dBc (TOI = +15 dBm) (300MHz \leq Frequency \leq 1GHz, RF input level ≤ -5 dBm) ≤ -60 dBc (TOI = +15 dBm) (1GHz < Frequency < 3.5GHz, RF input level $\leq +5$ dBm) ≤ -58 dBc (TOI = +14 dBm) (3.5GHz \leq Frequency \leq 6GHz, Frequency Band Mode: Normal, RF input level $\leq +5$ dBm) ≤ -54 dBc (TOI = +12 dBm) Nominal (30MHz \leq Frequency < 300MHz, RF input level ≤ 0 dBm) ≤ -60 dBc (TOI = +15 dBm) Nominal (300MHz \leq Frequency < 3.5GHz, RF input level $\leq +15$ dBm) ≤ -58 dBc (TOI = +14 dBm) Nominal (3.5GHz \leq Frequency \leq 6GHz, Frequency Band Mode: Normal, RF input level $\leq +15$ dBm)

Table 1.3.1-3 Specifications for spectrum analyzer function (Continued)

Item	Specification
Image response	<p>With MS2830A-040/041/043 installed, Frequency Band Mode: Normal ≤ -70 dBc (10 MHz \leq frequency < 4 GHz) ≤ -55 dBc (4 GHz \leq frequency \leq 6 GHz) ≤ -60 dBc (6 GHz < frequency \leq 13.5 GHz)</p> <p>With MS2830A-062 installed and operating (Opt-062 enabled, 3.6 GHz max. center frequency, \leq 1 MHz SPAN as spectrum analyzer) ≤ -10 dBc (This is generated at “input signal + 150 MHz”) (330 MHz \leq frequency < 3.6 GHz)</p> <p>With MS2830A-066 installed and operating (066: Enabled, Center frequency: 3.6 GHz or less, and SPAN \leq 1 MHz as spectrum analyzer). ≤ -10 dBc (This is generated at “input signal + 150 MHz.”) (110 MHz \leq frequency < 3.6 GHz)</p> <p>With MS2830A-044/045 installed, When MS2830A-067/167 is NOT installed ≤ -70 dBc (10 MHz \leq frequency < 4 GHz) ≤ -55 dBc (4 GHz \leq frequency \leq 6 GHz) ≤ -70 dBc (6 GHz < frequency \leq 13.5 GHz) ≤ -70 dBc (13.5 GHz < frequency \leq 26.5 GHz)</p>
Multiple Response (330 MHz \leq Frequency < 3.6 GHz)	<p>With MS2830A-040/041/043 installed, With MS2830A-062/066 installed and operating (Opt-062/066 enabled, 3.6 GHz max. center frequency, SPAN \leq 1 MHz as spectrum analyzer), and -15 dBm mixer input level ≤ -10 dBc Nominal</p>

Table 1.3.1-3 Specifications for spectrum analyzer function (Continued)

Item	Specification
Sweep	
Sweep mode	Single, Continuous
Sweep time	1 ms to 1000 s (SPAN \geq 300 Hz)
Setting range	1 μ s to 1000 s (SPAN = 0 Hz)
Detection mode	Pos&Neg, Positive Peak, Sample, Negative Peak, RMS
The number of trace points	When SPAN > 30 GHz: 5001, 10001 When 500 MHz < SPAN \leq 30 GHz: 1001, 2001, 5001, 10001 When 300 Hz \leq SPAN \leq 100 MHz and Sweep Time > 10 s: 101, 201, 251, 401, 501, 1001, 2001, 5001, 10001 When 300 Hz \leq SPAN \leq 100 MHz and Sweep Time \leq 10 s: 11, 21, 41, 51, 101, 201, 251, 401, 501, 1001, 2001, 5001, 10001 When Span = 0 Hz: 11, 21, 41, 51, 101, 201, 251, 401, 501, 1001, 2001, 5001, 10001
Scale	
Log indicator	10div/12div : 0.1 to 20 dB/div, 1-2-5 sequence
Lin indicator	10div : 1 to 10%/div, 1-2-5 sequence
Trigger function	
Trigger mode	Free Run (Trig Off), Video, Wide IF Video, External, Frame SG Marker (With MS2830A-020/120/021/121)
Gate function	
Gate mode	Off, Wide IF Video, External, Frame SG Marker (With MS2830A-020/120/021/121)

Table 1.3.1-3 Specifications for spectrum analyzer function (Continued)

Item	Specification
Measurement function	
Adjacent Channel Power Measurement (ACP) Reference Adjacent channel specification	Span Total, Carrier Total, Both Sides of Carriers or Carrier Select 3 channels × 2 (Normal Mode) 8 channels × 2 (Advanced Mode)
Burst arrange	Indicates average power of specified time in the time domain mode
Channel Power Absolute value measurement	dBm, dBm/Hz
Occupied Bandwidth (OBW)	N% of Power method, X dB Down method
Spectrum Emission Mask (SEM)	Peak/Margin measurement: Pass/fail judgment is performed by Peak/Margin measurement.
Spurious Emission	Worst/Peaks measurement: Pass/fail judgment is performed by Worst/Peaks measurement
Frequency counter Counter accuracy	$\pm(\text{marker frequency} \times \text{reference frequency accuracy} + (0.1 \times N/\text{Gate Time[s]}) \text{ Hz})$ at SPAN ≤ 1 MHz, RBW = 1 kHz, S/N ≤ 50 dB, Gate Time ≥ 100 ms Mixer harmonic order [N]
Two-tone third-order intermodulation distortion	Measures IM3 and TOI from two-tone signal.

1.3.2 Rubidium Reference Oscillator Option (MS2830A-001/101)**Table 1.3.2-1 Rubidium Reference Oscillator Specifications**

Items	Specifications
Function and Performance	See Table 1.3.1-1, “Internal reference oscillator”.

1.3.3 High Stability Reference Oscillator Option (MS2830A-002/102)**Table 1.3.3-1 High Stability Reference Oscillator Option Specifications**

Item	Specification
Function and Performance	See Table 1.3.1-1, “Internal reference oscillator”
Others	This option is not available when MS2830A-044/045 is installed.

1.3.4 Preamplifier Option (MS2830A-008/108)

Table 1.3.4-1 lists the specifications for the preamplifier.

The following specification values are those under the conditions after 30-min warm-up at stable ambient temperature. Typical values are only for reference and are not guaranteed.

Table 1.3.4-1 Preamplifier Option Specifications

Item	Specification
Frequency	
Frequency range	100 kHz to 3.6 GHz (With MS2830A-040) 100 kHz to 6 GHz (With MS2830A-041/043)
Amplitude	
Measurement range	See Table 1.3.1-1, “Internal reference oscillator”
Maximum input level	See Table 1.3.1-1, “Internal reference oscillator”
Display average noise level (Signal Analyzer function)	See Table 1.3.1-2, “Display average noise level”.
Display average noise level (Spectrum analyzer function)	See Table 1.3.1-3, “Display average noise level”.
RF Frequency Characteristics	See Table 1.3.1-1, “RF frequency characteristics”.
Input attenuator switching error	See Table 1.3.1-1, “Input attenuator switching error”.
Linearity error	See Table 1.3.1-1, “Linearity error”.
Secondary harmonic wave distortion	See Table 1.3.1-1, “Secondary harmonic wave distortion”.
1 dB gain compression	See Table 1.3.1-1, “1 dB gain compression”.
Two-tone third-order intermodulation distortion	See Table 1.3.1-3, “Two-tone third-order intermodulation distortion”.
Others	Cannot install simultaneously with MS2830A-068/168.

1.3.5 Analysis Bandwidth Extension to 31.25 MHz Option (MS2830A-005/105)

Table 1.3.5-1 Analysis Bandwidth Extension to 31.25 MHz Option Specifications

Item	Specification
Function and Performance	Function to analyze 31.25 MHz bandwidth
Others	This option is not available when MS2830A-045 is installed.

1.3.6 Analysis Bandwidth Extension to 10 MHz Option (MS2830A-006/106)

Table 1.3.6-1 Analysis Bandwidth Extension to 10 MHz Option Specifications

Item	Specification
Function and Performance	Function to analyze 10 MHz bandwidth

1.3.7 Phase Noise Measurement Option (MS2830A-010/110)

Table 1.3.7-1 Phase Noise Measurement Function Specifications

Item	Specification
Function	Displays the phase noise characteristics on a logarithmic scale
Frequency	
Range	10 MHz to Upper frequency limit
Offset frequency range	10 Hz to 10 MHz
Marker Mode	Normal, Integral Noise, RMS Noise, Jitter, Residual FM, Off

1.3.8 Secondary HDD Option (MS2830A-011/111)

Table 1.3.8-1 Secondary HDD Option Specifications

Item	Specification
Use	Removable HDD for storing user data Insert into the HDD (Opt) slot on the back panel to use.  Figure 3.1.1-2 Rear panel "16 HDD slot for options"

1.3.9 Precompliance EMI Function (MS2830A-016/116)

Table 1.3.9-1 Precompliance EMI Function Option Specifications

Item	Specification
Function	Adds the Detection Mode and the Resolution Bandwidth for EMI measurement to the Spectrum Analyzer function.
Detection Mode (CISPR Detector)	Quasi-Peak, CISPR-AVG, RMS-AVG
Resolution Bandwidth (CISPR RBW)	200 Hz (6 dB BW), 9 kHz (6 dB BW), 120 kHz (6 dB BW), 1 MHz (Impulse)

1.3.10 Low Phase Noise Performance Option (MS2830A-062/066)

Summary:

The SSB phase noise is improved for RF input signals by provision of an internal dedicated frequency converter.

Precautions when Low Phase Noise option enabled (On).

The operation principle of the frequency converter is generation of a spurious response at a specific frequency. As a result, sometimes it is better not to use, such as when measuring spurious.

When the DUT signal frequency is known, when the MS2830A Rx frequency is set to 35 MHz beyond that frequency, measurement can be made as if the Low Phase Noise Function is Off (disabled) because the spurious response cannot be observed.

However, even if the DUT signal frequency is unknown, measurement can be made after setting the Low Phase Noise Function to Off (disabled) and verifying the presence of a response at about the same level (in other words, confirming that the observed signal has the correct response).

The spurious responses are as follows:

(1) Image Response

This response is generated when a signal with frequency f_{in} is input to the MS2830A RF input connector and the MS2830A Rx frequency is set to $f_{in} - 150$ MHz, and more than 330 MHz (with MS2830A-062) or more than 110 MHz (with MS2830A-066). The generated level is about -20 dBc.

(2) Multiple Response

This response is generated when a signal with frequency f_{in} is input to the MS2830A RF input connector and the MS2830A Rx frequency is set to $(f_{in} \pm 75 \text{ MHz})/N - 75$ MHz ($N = 1, 2, 3 \dots$), and more than 330 MHz (with MS2830A-062) or more than 110 MHz (with MS2830A-066). The generated level is about -10 dBc.

Table 1.3.10-1 Low Phase Noise Performance Specifications

Item	Specification
Frequency	
Frequency Range	9 kHz to 3.7 GHz 9 kHz to 3.5 GHz (Frequency Band Mode: Spurious)
SPAN	1 kHz to 31.25 MHz (Signal Analyzer function) 300 Hz to 1 MHz (Spectrum Analyzer function)
Single side band noise	See Table 1.3.1-1, "Single side band noise".
Resolution bandwidth (RBW)	See Table 1.3.1-3, "Specifications for spectrum analyzer function, Resolution bandwidth (RBW)".
Amplitude	
Display average noise level (Signal Analyzer function)	See Table 1.3.1-2, "Specifications for Signal Analyzer Function, Display average noise level".
Display average noise level (Spectrum analyzer function)	See Table 1.3.1-3, "Specifications for spectrum analyzer function, Display average noise level".
Spurious Response	
Image response	See Table 1.3.1-3, "Specifications for spectrum analyzer function, Image response".

1.3.11 Removable HDD option (MS2830A-313)

Table 1.3.11-1 Removable HDD Option Specification

Item	Specification
Use	This is a spare hard disk for the MS2830A to replace the disk. Insert into the HDD slot on the back panel to use.  Figure 3.1.1-2 Rear panel "15 HDD slot"

1.3.12 Microwave Preamplifier Option (MS2830A-068/168)

This option amplifies signal prior to 1st mixer to enhance sensitivity.

This option is the wideband version of Preamplifier Option (MS2830A-008/108), and can be used on the application software in a similar way.

Table 1.3.12-1 Microwave Preamplifier Option Specifications

Item	Specification
Frequency	
Frequency range	100 kHz to 26.5 GHz (With MS2830A-044) 100 kHz to 43 GHz (With MS2830A-045)
Amplitude	
Measurement range	See Table 1.3.1-1, “Internal reference oscillator”
Maximum input level	See Table 1.3.1-1, “Specifications for Mainframe, Maximum input level”
Display average noise level (Signal Analyzer function)	See Table 1.3.1-2, “Specifications for Signal Analyzer Function, Display average noise level”.
Display average noise level (Spectrum analyzer function)	See Table 1.3.1-3, “Display average noise level”.
RF Frequency Characteristics	See Table 1.3.1-1, “Specifications for Mainframe, RF frequency characteristics”.
Input attenuator switching error	See Table 1.3.1-1, “Specifications for Mainframe, Input attenuator switching error”.
Linearity error	See Table 1.3.1-1, “Specifications for Mainframe, Linearity error”.
Secondary harmonic wave distortion	See Table 1.3.1-1, “Specifications for Mainframe, Secondary harmonic wave distortion”.
1 dB gain compression	See Table 1.3.1-1, “Specifications for Mainframe, 1 dB gain compression”.
Two-tone third-order intermodulation distortion	See Table 1.3.1-3, “Specifications for spectrum analyzer function, Two-tone third-order intermodulation distortion”.
Others	Cannot install simultaneously with MS2830A-008/108.

1.3.13 Microwave Preselector Bypass Option (MS2830A-067/167)

Summary:

By bypassing the preselector (image response elimination filter), the RF frequency characteristics and the in-band frequency characteristics are improved, and level accuracy improvement can be achieved.

Notes on default values when this option is installed:

To improve the in-band frequency characteristics, the default value is set to On for the Signal Analyzer function, and is always set to On for all other applications.

To avoid measuring the image signals generated internally, the default value is set to Off for the Spectrum Analyzer function.

Table 1.3.13-1 Microwave Preselector Bypass Option Specifications

Item	Specification
Intended Use	Bypasses the preselector to improve the RF frequency characteristics and the in-band frequency characteristics. When this function is set to On, the image response elimination filter is bypassed. Therefore, this function is not appropriate for image response reception and spurious measurement.
Function and performance	
Frequency	
Frequency range	4 GHz to 26.5 GHz (MS2830A-044) 4 GHz to 43 GHz (MS2830A-045)
Amplitude	
RF frequency characteristics	After CAL execution at 18°C to 28°C, input attenuator = 10 dB, With Microwave Preselector Bypass turned on, Without MS2830A-068/168 or with Preamplifier turned off: ±1.00 dB (6 GHz ≤ frequency ≤ 13.8 GHz, Frequency Band Mode: Normal) (4 GHz ≤ frequency ≤ 13.8 GHz, Frequency Band Mode: Spurious) ±1.50 dB (13.8 GHz < frequency ≤ 26.5 GHz) ±2.00 dB (26.5 GHz < frequency ≤ 40 GHz) ±2.00 dB typ. (40 GHz < frequency ≤ 43 GHz)

Table 1.3.13-1 Microwave Preselector Bypass Option Specifications (Continued)

Item	Specification
RF frequency characteristics (Continued)	With Microwave Preselector Bypass turned on, With MS2830A-068/168 or with Preamplifier turned on: ±1.8 dB (6 GHz ≤ frequency ≤ 13.8 GHz, Frequency Band Mode: Normal) (4 GHz ≤ frequency ≤ 13.8 GHz, Frequency Band Mode: Spurious) ±2.50 dB (13.8 GHz < frequency ≤ 26.5 GHz) ±3.00 dB (26.5 GHz < frequency ≤ 40 GHz) ±3.00 dB Nominal (40 GHz < frequency ≤ 43 GHz)
Display average noise level	At 18°C to 28°C, Detector = Sample, VBW = 1 Hz (Video Average) At input attenuator 0 dB, Irrespective of Microwave Preselector Bypass turned on/off, Without MS2830A-068/168 installed, With MS2830A-044/045, 6 GHz < frequency ≤ 13.5 GHz -147 [dBm/Hz] 13.5 GHz < frequency ≤ 18.4 GHz -145 [dBm/Hz] 18.4 GHz < frequency ≤ 26.5 GHz -141 [dBm/Hz] With MS2830A-045, 26.5 GHz < frequency ≤ 34 GHz -141 [dBm/Hz] 34 GHz < frequency ≤ 40 GHz -135 [dBm/Hz] 40 GHz < frequency ≤ 43 GHz -132 [dBm/Hz] With MS2830A-068/168 or with Preamplifier turned off: With MS2830A-044/045, 6 GHz < frequency ≤ 13.5 GHz -142 [dBm/Hz] 13.5 GHz < frequency ≤ 18.4 GHz -140 [dBm/Hz] 18.4 GHz < frequency ≤ 26.5 GHz -136 [dBm/Hz] With MS2830A-045, 26.5 GHz < frequency ≤ 34 GHz -136 [dBm/Hz] 34 GHz < frequency ≤ 40 GHz -131 [dBm/Hz] 40 GHz < frequency ≤ 43 GHz -128 [dBm/Hz]

Table 1.3.13-1 Microwave Preselector Bypass Option Specifications (Continued)

Item	Specification
Display average noise level (Continued)	With Microwave Preselector Bypass turned on, With MS2830A-068/168 and with Preamplifier turned on: With MS2830A-044/045, 6 GHz < frequency ≤ 13.5 GHz -154 [dBm/Hz] 13.5 GHz < frequency ≤ 18.4 GHz -152 [dBm/Hz] 18.4 GHz < frequency ≤ 26.5 GHz -150 [dBm/Hz] With MS2830A-045, 26.5 GHz < frequency ≤ 34 GHz -150 [dBm/Hz] 34 GHz < frequency ≤ 40 GHz -144 [dBm/Hz] 40 GHz < frequency ≤ 43 GHz -141 [dBm/Hz]
Image response	With Microwave Preselector Bypass turned off, -60 dBc (6 GHz < frequency ≤ 13.5 GHz) -60 dBc (13.5 GHz < frequency ≤ 13.5 GHz) With Microwave Preselector Bypass turned on, Generated at the frequency at the distance of 1875 MHz × 2 0 dBc Nominal (4 GHz < frequency ≤ 26.5 GHz) 0 dBc Nominal (26.5 GHz < frequency ≤ 43 GHz)
Others	Cannot be installed together with MS2830A-007

1.3.14 Bandwidth Extension to 31.25 MHz with Preselector Bypass Option (MS2830A-007)

This option adds a function to analyze 31.25 MHz bandwidth and a preselector option to Option 045.

It can be used in a similar way as Option 005/105 and Option 067/167 on the application software.

Table 1.3.14-1 Bandwidth Extension to 31.25 MHz with Preselector Bypass - Option Specifications

Item	Specification
Application	This option adds a function to analyze 31.25 MHz bandwidth and a preselector option to Option 045 (43 GHz Signal Analyzer). When the preselector option is set to On, the image response elimination filter is bypassed. Therefore, this function is not appropriate for image response reception and spurious measurement.
Function and performance	
Display average noise level	Refer to Table 1.3.13-1 “Microwave Preselector Bypass Option Specifications: Display average noise level.”
RF frequency characteristics	Refer to Table 1.3.13-1 “Microwave Preselector Bypass Option Specifications: RF frequency characteristics.”
Others	Cannot be installed together with MS2830A-067/167

1.3.15 Analysis Bandwidth Extension Option, 62.5 MHz (MS2830A-077/177)

Table 1.3.15-1 Analysis Bandwidth Extension to 62.5 MHz Option Specifications

Item	Specification
Application	<p>Extends the analysis bandwidth to 62.5 MHz in single analyzer mode by bypassing a bandwidth-limiting filter such as a preselector and performing fast sampling.</p> <p>On the other hand, because an image response is received due to bypassing the image response elimination filter, this is not adequate for measuring spurious or out-of-analysis-band signals and analyzing signals.</p>
ADC resolution	14 bits
Image response	<p>With MS2830A-077/177 installed and Bandwidth > 31.25 MHz. To be generated at a frequency that is 200 MHz away. 0 dBc Nominal (300 MHz < frequency ≤ 43 GHz)</p> <p>With MS2830A-077/177 and MS2830A-067/167 installed and Bandwidth > 31.25 MHz. To be generated at a frequency that is 1875 MHz × 2 away. 0 dBc Nominal (6 GHz < frequency ≤ 43 GHz)</p>
Others	

1.3.16 Analysis Bandwidth Extension Option, 125 MHz (MS2830A-078/178)

Table 1.3.16-1 Analysis Bandwidth Extension to 125 MHz Option Specifications

Item	Specification
Application	Extends the analysis bandwidth to 125 MHz in single analyzer mode by bypassing a bandwidth-limiting filter such as a preselector and performing fast sampling. On the other hand, because an image response is received due to bypassing the image response elimination filter, this is not adequate for measuring spurious or out-of-analysis-band signals and analyzing signals.
ADC resolution	14 bits
Image response	With MS2830A-078/178 installed and Bandwidth > 31.25 MHz. To be generated at a frequency that is 200 MHz away. 0 dBc Nominal (300 MHz < frequency ≤ 43 GHz) With MS2830A-078/178 and MS2830A-067/167 installed and Bandwidth > 31.25 MHz. To be generated at a frequency that is 1875 MHz × 2 away. 0 dBc Nominal (6 GHz < frequency ≤ 43 GHz)
Others	

1.3.17 Bandwidth Extension to 31.25MHz for Millimeter-wave (MS2830A-009/109)

Table 1.3.17-1 Bandwidth Extension to 31.25MHz for Millimeter-wave Specifications

Item	Specification
Application	Extends the analysis bandwidth to 31.25 MHz in signal analyzer mode.
Others	This option is available only when MS2830A-045 is installed.

1.3.18 BER Measurement function (MS2830A-026/126)

Table 1.3.18-1 BER Measurement function Specifications

Item	Specification
Connector	Rear panel Aux connector
Input level	TTL level
Input signal	Data, Clock, Enable
Input bit rate	100 bps to 10 Mbps
Measurable patterns	PN9, PN11, PN15, PN20, PN23, ALL0, ALL1, repetition of 01 PN9Fix, PN11Fix, PN15Fix, PN20Fix, PN23Fix UserDefine (4096 bits max.)
Synchronization establishing condition	PN signal: No error has been detected for (PN stage count × 2) bits PNFix signal: Synchronization with the PN signal is established if no error has been detected for (PN stage count × 2) bits. Next, the cycle and synchronization of the PNFix signal are established if no error has been detected for PN stage count bits beginning with the start bit of the PNFix signal. ALL0, ALL1, repetition of 01: No error has been detected for 10 bits. UserDefine: No error has been detected for 8 to 1024 bits (variable). The start bit used for synchronization detection can also be selected.
Re-synchronization judgment condition	x/y (Resynchronization is executed if x bits out of y bits are errors.) y (Measurement bit count): Selected from 500 bits, 5000 bits, and 50000 bits x (Error bit count out of y bits): 1 to y/2 bits
Measurable bit count	$\leq 2^{32} - 1$ bit
Measurable error bit count	$\leq 2^{31} - 1$ bit
Measurement termination condition	Measurement bit count, measurement error bit count
Auto Resync function	Can be switched between enable/disable.
Count operation at resynchronization	Can be selected from Count Clear and Count Keep.
Measurement mode	Continuous, Single, Endless
Display	Status, Error, Sync Loss, Error Rate, Error Count, SyncLoss Count Measurement bit count
Polarity reversal function	Data, Clock, and Enable polarities can be reversed.
Measured value clear function	It is possible to clear the measured values to 0 while retaining synchronization during BER measurement, and start the measurement again from 0.

Chapter 2 Before Use

This chapter describes items that you should know before using the MS2830A. Be sure to read this section at least once as it contains safety tips and cautions for avoiding failure during use.

2.1	Installation Location	2-2
2.1.1	Installation orientation.....	2-2
2.1.2	Distance from surrounding objects.....	2-3
2.1.3	Installation location conditions.....	2-3
2.2	Items to Check Before Use.....	2-4
2.2.1	Safety labels	2-4
2.2.2	Input level and reverse power (when vector signal generator is installed) to RF Input.....	2-5
2.2.3	Electrostatic	2-6
2.2.4	Notes on handling input connector and SG output connector (when vector signal generator is installed)	2-8
2.2.5	USB memory	2-8
2.3	Power Connection	2-9
2.3.1	Power requirements	2-9
2.3.2	Connecting power cord	2-9

2.1 Installation Location

2.1.1 Installation orientation

Install the MS2830A horizontally or at an angle using the tilted legs as shown in Figure 2.1.1-1. Do not place objects on top of the MS2830A when tilted.



Figure 2.1.1-1 Installation orientation

CAUTION

If the MS2830A is not installed in a “OK” direction as above, a small shock may turn it over and harm the user.

2.1.2 Distance from surrounding objects

A fan is installed to the MS2830A to prevent the internal temperature from rising. Install the MS2830A in a location with the vents at least 10 cm away from walls, peripherals or other obstructions so as not to block the fan perimeter.

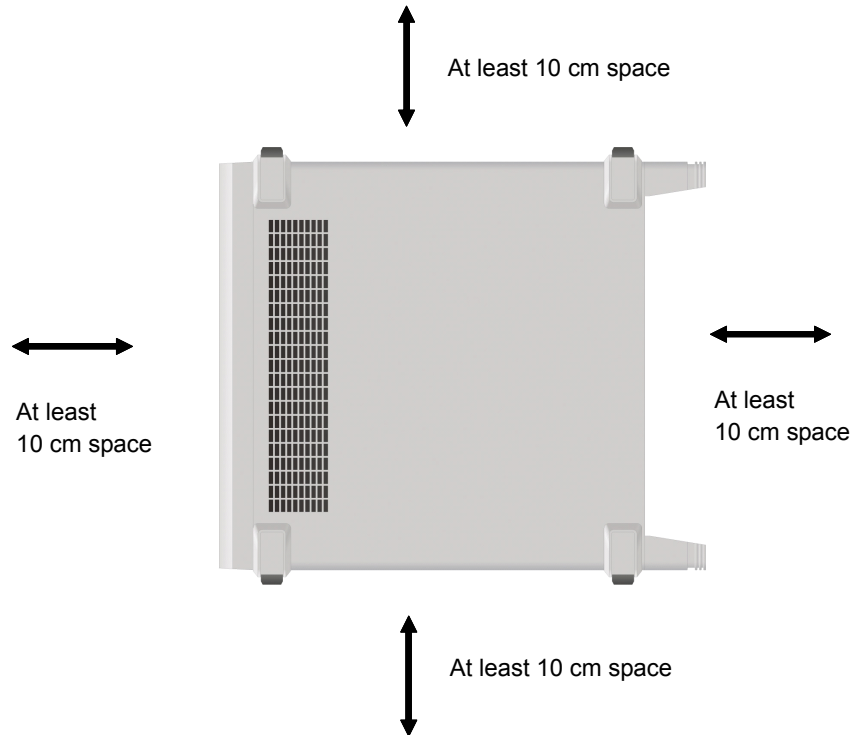

Figure 2.1.2-1 Distance from surrounding objects

2.1.3 Installation location conditions

Although the MS2830A operates at an ambient temperature of 5° to 45°C, avoid using it in locations, such as the following, since it may cause failure.

- Locations with strong vibrations
- Humid and dusty locations
- Locations with direct sunlight
- Locations where there is the risk of exposure to active gases
- Locations where power voltage severely fluctuates

2.2 Items to Check Before Use

2.2.1 Safety labels

To protect the safety of the user, the WARNING label shown in Figure 2.2.1-1 is affixed to the rear panel. Observe the instructions on the label.

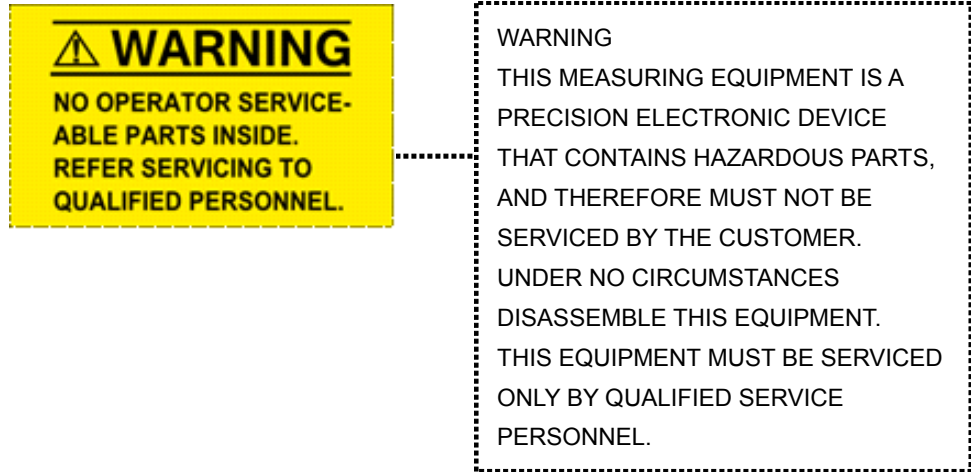

Figure 2.2.1-1 Warning labels

2.2.2 Input level and reverse power (when vector signal generator is installed) to RF Input

The MS2830A is not provided with over-power protection. Be careful not to apply reverse power to the RF Input connector as described below:

For Option 040/041/043, without Option 008/108 installed, or with Preamplifier turned off:

+30 dBm Max (Input attenuator ≥ 10 dB), ± 10 Vdc Max

For Option 040/041/043, with Option 008/108 installed, and with Preamplifier turned on:

+10 dBm Max (Input attenuator = 0 dB), ± 10 Vdc Max

For Option 044/045, without Option 068/168 installed, or with Preamplifier turned off:

+30 dBm Max (Input attenuator ≥ 10 dB), ± 0 Vdc Max

For Option 044/045, with Option 068/168 installed, and with Preamplifier turned on:

+10 dBm Max (Input attenuator = 0 dB), ± 0 Vdc Max

There is no reverse power protection for the SG output connector when the Vector Signal Generator Option is installed. Be careful not to apply reverse power to the SG Output connector as described below:

When Option 022/122 is NOT installed:

+12 dBm Max (<20 MHz), +24 dBm Max (≥ 20 MHz)

When Option 022/122 is installed:

+18 dBm Max (<20 MHz), +30 dBm Max (≥ 20 MHz)

In addition, do not apply DC voltage even when within the range described above.

2.2.3 Electrostatic

 **CAUTION**

- Always use the supplied 3-pin power cord to ground both the MS2830A and DUT (included in test circuit). After confirming that both the MS2830A and DUT are grounded, use coaxial cables to connect them. NEVER connect the MS2830A and DUT without grounding, otherwise electrostatic discharge may damage the MS2830A.
 - Do not touch the core conductor of the connector or bring it into contact with metal. Doing so may damage the input circuit of the MS2830A.
-

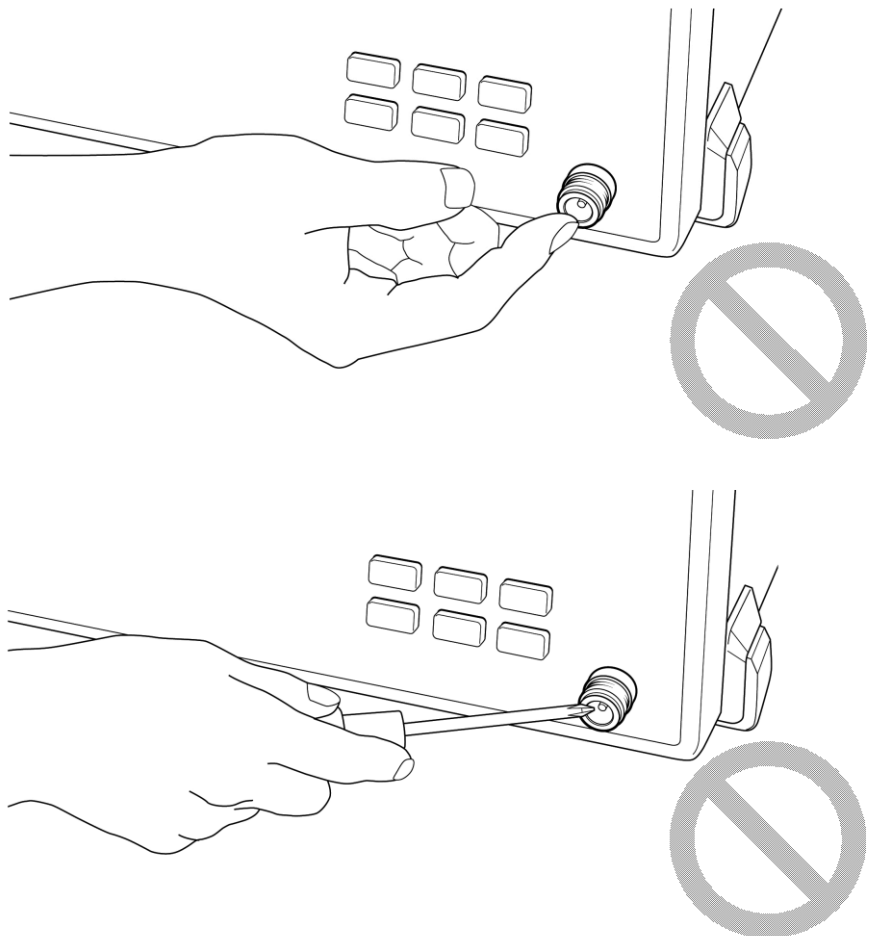

⚠ CAUTION

Do not touch the core conductor of the coaxial cable connected to the input connector or bring it into contact with metal.

Doing so may damage the input circuit of the MS2830A.

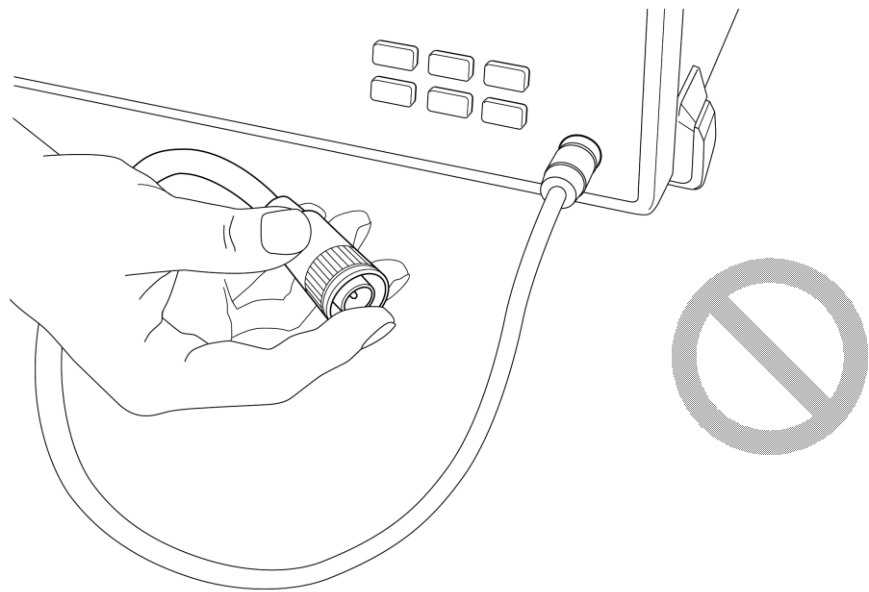

⚠ CAUTION

Do not touch the core conductor to the metal when connecting the coaxial cable to the connector.

Doing so may damage the input circuit of the MS2830A.

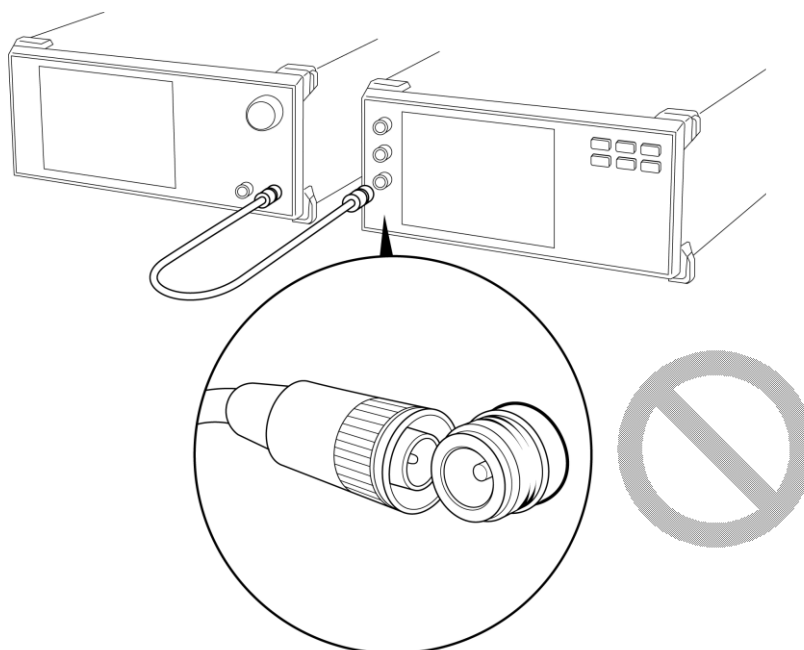

2.2.4 Notes on handling input connector and SG output connector (when vector signal generator is installed)

For Option 040/041/043, only connect N-type connector to RF Input and SG Output. For Option 044/045, only connect K-type connector to RF Input. Connecting a different connector will damage the connector.

2.2.5 USB memory

Note the orientation of the connection when using a USB memory. Plugging in a USB memory in the wrong direction may damage the connector.

2.3 Power Connection

This section describes the procedures for supplying power.

2.3.1 Power requirements

For normal operation of the MS2830A, observe the power voltage range described below.

Power source	Voltage range	Frequency
100 Vac system	100 to 120 V	50 to 60 Hz
200 Vac system	200 to 240 V	50 to 60 Hz

Changeover between 100 and 200 V system is made automatically.

The maximum power consumption of the MS2830A is 350 VA. Provide sufficient power capacity.

CAUTION

Supplying power exceeding the above range may result in electrical shock, fire, failure, or malfunction.

2.3.2 Connecting power cord

Insert the power plug into a grounded outlet, and connect the other end to the power inlet on the rear panel. To ensure that the instrument is properly grounded, always use the supplied 3-pin power cord.

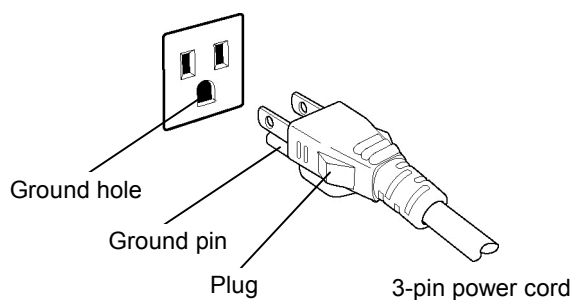

WARNING

Always connect the instrument to a properly grounded outlet. Do not use the instrument with an extension cord or transformer that does not have a ground wire.

If the instrument is connected to an ungrounded outlet, there is a risk of receiving a fatal electric shock. In addition, the peripheral devices connected to the instrument may be damaged.

Unless otherwise specified, the signal-connector ground terminal, like an external conductor of the coaxial connector, of the instrument is properly grounded when connecting the power cord to a grounded outlet. Connect the ground terminal of DUT to a ground having the same potential before connecting with the instrument. Failure to do so may result in an electric shock, fire, failure, or malfunction.

CAUTION

If an emergency arises causing the instrument to fail or malfunction, disconnect the instrument from the power supply by disconnecting either end of the power cord.

When installing the instrument, place the instrument so that an operator may easily connect or disconnect the power cord from the power inlet and outlet. Moreover, **DO NOT** fix the power cord around the plug and the power inlet with a holding clamp or similar device.

If the instrument is mounted in a rack, a power switch for the rack or a circuit breaker may be used for power disconnection.

It should be noted that, the power switch on the front panel of the instrument is a standby switch, and cannot be used to cut the main power.

Chapter 3 Common Operations

This chapter describes items to be understood before actually operating the MS2830A, including part names, basic parameter setting methods, modulation operation method and useful functions.

3.1	Part Names	3-2
3.1.1	Part names	3-2
3.2	Turning Power On/Off	3-11
3.2.1	Turning power On	3-11
3.2.2	Turning power Off	3-12
3.3	Auto Calibration	3-13
3.4	Settings on Configuration Screen	3-16
3.4.1	Display description	3-17
3.4.2	Interface Settings	3-18
3.4.3	Copy Settings	3-19
3.4.4	System Settings	3-20
3.4.5	Application Switch Settings	3-23
3.4.6	System Information	3-24
3.4.7	Option Information	3-25
3.4.8	File Operation	3-25
3.4.9	Software Install/Uninstall	3-26
3.4.10	Correction	3-26
3.5	Loading, Unloading, and Switching Applications	3-30
3.5.1	Loading applications	3-31
3.5.2	Unloading applications	3-33
3.5.3	Switching applications	3-35
3.5.4	Changing application layout	3-36
3.6	Save and Recall Functions	3-39
3.6.1	Saving parameters and waveform data	3-39
3.6.2	Recalling parameters	3-41
3.6.3	Screen hard copy	3-43
3.6.4	Simple Save&Recall	3-44
3.7	Initializing	3-48
3.7.1	Preset	3-48
3.7.2	System Reset	3-49
3.8	Installing and Uninstalling	3-50
3.8.1	Installing software	3-50
3.8.2	Uninstalling software	3-54

3.1 Part Names

3.1.1 Part names

Front Panel

This section describes the keys and connectors located on the front panel.

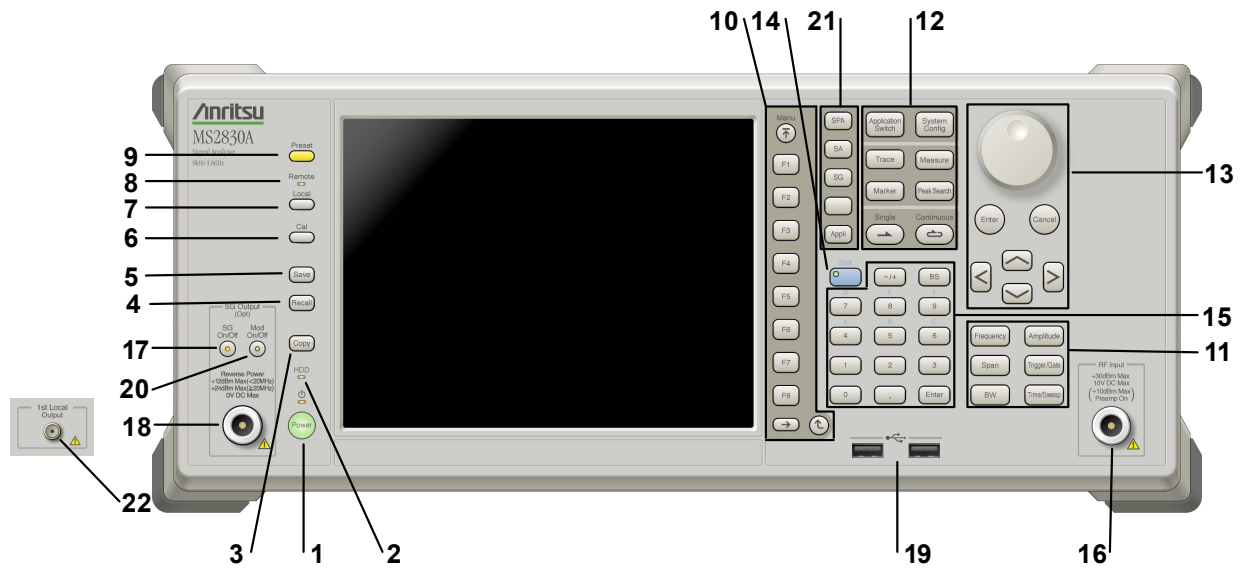



























Figure 3.1.1-1 Front Panel

- 1  **Power Switch**
 **Power**
 Press to switch between the standby state in which AC power is supplied and the Power On state in which the MS2830A is under operation. The Power lamp  lights up orange in the standby state, and lights up green in the Power On state. Press the power switch for a reasonably long duration (for about two seconds).
- 2  **HDD**
Hard disk access lamp
 Lights up when the MS2830A internal hard disk is being accessed.
- 3  **Copy**
Copy key
 Press to capture a screen image from the display and save it to a file.
- 4  **Recall**
Recall key
 Press to recall a parameter file.

- | | | |
|----|---|---|
| 5 |  | <p>Save key
Press to save a parameter file.</p> |
| 6 |  | <p>Cal key
Press to display the calibration execution menu.</p> |
| 7 |  | <p>Local key
Press to return to local operation from remote control operation through GPIB, Ethernet or USB (B), and enable panel settings.</p> |
| 8 |  | <p>Remote lamp
Lights up when the MS2830A is in a remote control state.</p> |
| 9 |  | <p>Preset key
Resets parameters to their initial settings.</p> |
| 10 | 







  | <p>Function keys
Used for selecting or executing function menu displayed on the right of the screen. The function menu contents are provided in multiple pages and layers.</p> <p>The number on the bottom of the screen indicates the menu page number.</p> |
| |  | <p>Next key
Press to go to the next page.</p> |
| |  | <p>Back key
Press to go back to the previous layer within the function menu.</p> |
| |  | <p>Top key
Press to go back to the uppermost (top) layer.</p> |

11





Main function keys 1

Used to set or execute main functions of the MS2830A.
 Executable functions vary depending on the application currently selected.

 Press to set parameters related to frequency.

 Press to set parameters related to level.

 Press to set parameters related to frequency span.

 Press to set parameters related to trigger.

 Press to set parameters related to RBW/VBW.

 Press to set parameters related to Time/Sweep.

12



Main function keys 2

Used to set or execute main functions of the MS2830A.
 Executable functions vary depending on the application currently selected.

 Press to switch an application.

 Press to display the Configuration screen.

 Press to set parameters related to trace.

 Press to set parameters related to the measurement function.

 Press to set parameters related to the marker function.

 Press to set parameters related to the peak search function.

 Press to start a single measurement.

 Press to start continuous measurements.

13

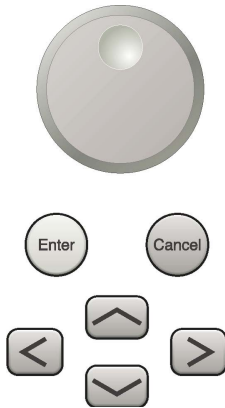
**Rotary knob/Cursor keys/Enter key/Cancel key**

The rotary knob and cursor keys are used to select display items or change settings.

Pressing  fixes the entered or selected data.

Pressing  cancels the entered or selected data.

14

**Shift key**

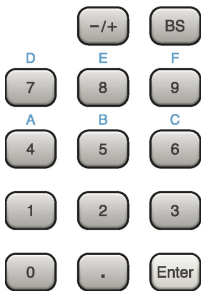

Used to operate any keys with functions described in blue characters on the panel. First press the Shift key, then press the target key when the Shift key lamp lights up green.

15

**Numeric keypad**

Used to enter numbers on parameter setup screens.

Pressing  deletes the last entered digit or character.

Hexadecimal values [A] to [F] can be entered by pressing  to  when the Shift key lamp  lights up green.

16

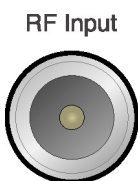
**RF Input****RF Input connector**

Inputs an RF signal.

17

**SG On/Off****RF output control key**

If the Vector Signal Generator option is installed, pressing  enables (On) or disables (Off) the RF signal output. The lamp of the RF output control key lights up orange when the RF signal output is set to On. This is not available when the Option 044/045 is installed.

18 SG Output(Opt)



RF output connector

Outputs an RF signal, when the vector signal generator option is installed.

This is not available when the Option 044/045 is installed.

19

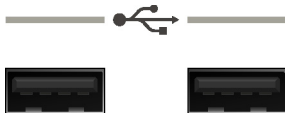

USB connector (type A)

Used to connect a USB keyboard or mouse or the USB memory supplied with the MS2830A.

20



Modulation control key

When the vector signal generator option is installed, RF signal modulation can be turned on and off by pressing  .

When modulation is on, the key lamp lights up green.

This is not available when the Option 044/045 is installed.

21



Application key

Press to switch between applications.



SPA key

Press to display the Spectrum Analyzer main screen.



SA key

Press to display the Signal Analyzer main screen, when Option 005/105, 066/106/, 007, 009/109, and 077/177/078/178 is installed.



SG key

Press to display the Signal Analyzer main screen, when Vector Signal Generator option is installed.



Blank key

Not used.



Appli key

When Auto is specified, the application selected by using the Application Switch is displayed. When Manual is specified, the pre-specified Application is displayed. Refer to 3.5.4 Changing application layout in “MS2830A Signal Analyzer Operation Manual (Mainframe Operation)”.

22

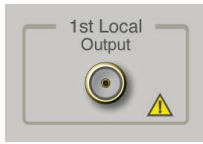

1st Local Output connector

This is available when the Option 044/045 is installed.

Supplies local signal and bias current to the external mixer, and receives the IF signal with its frequency converted.

Rear panel

This section describes the connectors located on the rear panel.

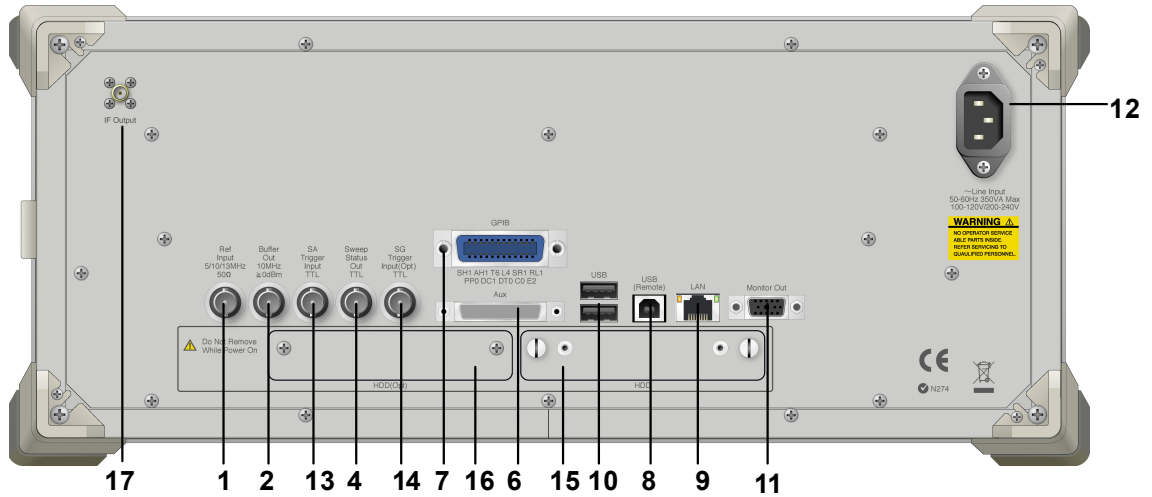



Figure 3.1.1-2 Rear panel

- 1 **Ref Input**



Ref Input connector (reference frequency signal input connector)
Inputs an external reference frequency signal (5 MHz/10 MHz/13 MHz). It is used for inputting reference frequency signals with accuracy higher than that of those inside the MS2830A, or for synchronizing the frequency of the MS2830A to that of other device.
- 2 **Buffer Out**



Buffer Out connector (reference frequency signal output connector)
Outputs the reference frequency signal (10 MHz) generated inside the MS2830A. It is used for synchronizing the frequencies between other devices and the MS2830A based on the reference frequency signal output from this connector.
- 4 **Sweep Status Out**



Sweep Status Out connector
Outputs a signal that is enabled when an internal measurement is performed or measurement data is obtained.

6

**AUX connector**

This is a complex connector for inputting a baseband clock reference signal of the Vector Signal Generator (optional), and BER Measurement function (optional). See Table 3.1.1-1 for the internal pin assignment of the AUX connector.

Table 3.1.1-1 Pin assignment of AUX connector

Function	Pin Number	Signal Name
BER	24	BER_CLK
	25	GND
	48	BER_EN
	45	GND
	49	BER_DATA
	50	GND
SG	13	MARKER1
	11	GND
	38	MARKER2
	36	GND
	39	MARKER3
	16	GND
	42	PULS_MOD
	41	GND
	22	BB_REF_CLK
	20	GND

3

Common Operations

Do not connect anything to connectors not listed in Table 3.1.1-1, because they are interface connectors provided for device maintenance.

7

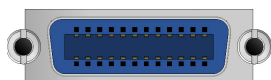
**GPIB connector**

Used when controlling the MS2830A externally via GPIB.

8 USB(Remote)

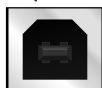
**USB connector (type B)**

Used when controlling the MS2830A externally via USB.

9

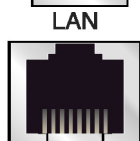
**Ethernet connector**

Used for connecting to a personal computer (PC) or for Ethernet connection.

10

USB



USB connectors (type A)

Used to connect a USB keyboard or mouse or the USB memory supplied with the MS2830A.

11



Monitor Out connector

Used for connection with an external display.

12



~Line Input
50-60Hz 440VA Max
100-120V/200-240V

AC inlet

Used for supplying power.

13

SA
Trigger
Input
TTL



SA Trigger Input connector

This is a BNC connector used to input the external trigger signal (TTL) for the SPA or SA application.

14

SG
Trigger
Input(Opt)
TTL



SG Trigger Input connector

This is a BNC connector used to input the external trigger signal (TTL) for the vector signal generator option.

15

HDD

HDD slot

This is a hard disk slot.

16

HDD (Opt)

HDD slot for options

This is a hard disk slot for the options.

17



IF output connector

Monitor output of the internal IF signal.



This is available when the Option 044/045 is installed.

3.2 Turning Power On/Off

3.2.1 Turning power On

The following shows the procedure for turning the power On.

<Procedure>

1. Plug in the power cord jack side to the AC power inlet on the rear panel. Make sure it is plugged all the way in at this time.
2. Plug the power cord plug side to the AC power outlet. The MS2830A enters standby state and the power switch  lamp lights up orange.
3. Press the power switch. The  lamp lights up green and startup begins.

Turning the power On starts Windows then the MS2830A software. The following startup screen is displayed during startup. Do not press the power switch while the startup screen is displayed. The software may not startup normally when the power switch is pressed.



Figure 3.2.1-1 Example of Startup Screen

3.2.2 Turning power Off

The following shows the procedure for turning the power Off.

When turning power Off using panel keys

<Procedure>

1. Press the power switch to close applications and start shutdown. The green power switch power lamp lights off, the  lamp lights up orange, and the power is turned Off. The main power is On at this time.

Note:

Do not press the power switch for more than 4 seconds. Doing so will forcibly shut down the system during software closing processing.

When turning power Off using mouse connected to MS2830A

<Procedure>

1. Connect the supplied mouse to the MS2830A and open the Start Menu from the Windows Taskbar.
2. Select “Turn off computer.”
3. Select “Turn off.”
4. Shutdown begins, the green power switch power lamp lights off, the  lamp lights up orange, and the power is turned Off. The main power is On at this time.

Forced shutdown

<Procedure>

1. Press the power switch for four seconds or more. The green power switch power lamp lights off, the  lamp lights up orange, and the power is turned Off.

Notes:

1. Use forced shutdown as an emergency operation only when key, mouse, or keyboard operations are disabled. A failure may have occurred in the event the power cannot be turned Off even after pressing the power switch for 4 or more seconds. Unplug the power cord from the outlet and contact an Anritsu Service and Sales office or agent.
2. Unplugging the power plug while accessing the hard disk may result in hard disk failures. Unplug the power plug when the power is turned Off.

3.3 Auto Calibration

An auto calibration function that uses an internal calibrating oscillator is provided to minimize measurement errors of the MS2830A.

CAUTION

Do not input signals to RF input when calibrating. Correct calibration values cannot be obtained when the auto calibrating function is executed while signals are being input.

3

Common Operations

Press  (Cal) to display the Cal function menu.

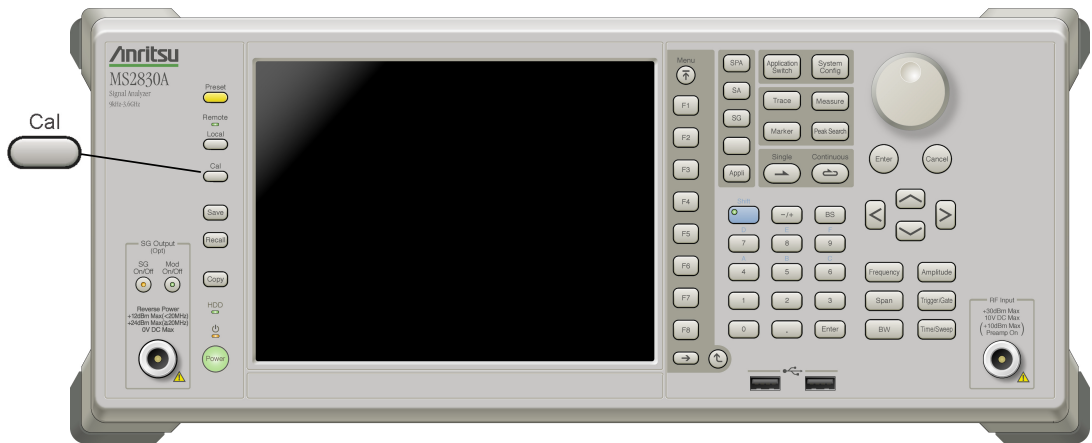

Figure 3.3-1 Cal key

Table 3.3-1 Cal function menu

Function Key	Menu Display	Function
F1	SIGANA All	Executes all calibrations (Level Cal, Band Cal, Local Leak Suppression, Extra Band Cal).
F2	Level Cal	Executes level calibration.
F3	Band Cal	Executes analysis band calibration.
F4	Local Leak Suppression	Executes local leak suppression.
F6	Extra Band Cal	Executes band calibration within the current frequency.
F8	Close	Returns to the application screen.

The auto calibration function includes the following three functions and a function to execute all three functions in a batch.

(1) Level calibration (Level Cal)

Calibrates reference level errors, RBW switching errors and input attenuator switching errors to minimize level measurement errors.

Example: Executing signal level calibration

<Procedure>



1. Press  (Cal).
2. Select  (Level Cal).

(2) Analysis band calibration (Band Cal)

Calibrates the frequency flatness and phase characteristics within the analyzed band.

Example: Executing analysis band calibration

<Procedure>



1. Press  (Cal).
2. Select  (Band Cal).

(3) Local Leak Suppression

Executes calibration to suppress local leaks affecting low frequency and low level measurements.



Example: Suppressing local leaks using local leak suppression function

<Procedure>

1. Press  (Cal).
2. Select  (Local Leak Suppression).

The following are the steps to batch execute all calibration functions.

<Procedure>



1. Press  (Cal).
2. Select  (SIGANA All).

(4) Extra Band Cal

Executes band calibration within the current frequency.

Example: Executes band calibration within the current frequency.

<Procedure>

1. Press  (Cal).
2. Select  (Extra Band Cal).

3.4 Settings on Configuration Screen

MS2830A system settings, and settings for system information display and common application functions can be configured in the Configuration screen.

Press  to display the Configuration screen.

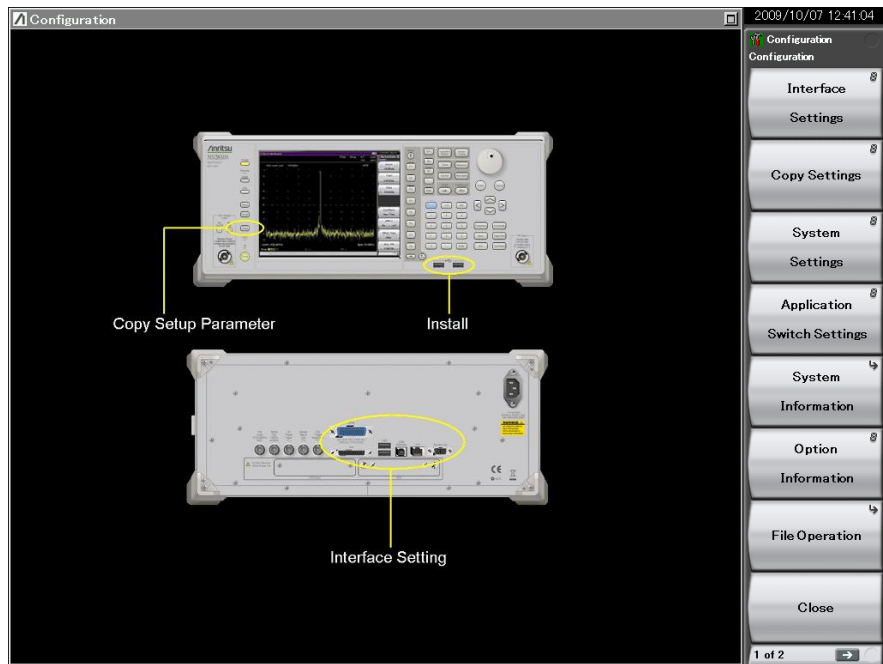

Figure 3.4-1 Configuration screen

3.4.1 Display description















The function menu in the Configuration screen consists of two pages, which can be toggled by pressing .

Table 3.4.1-1 Configuration menu

Function Key	Menu Display	Function
Page 1	Configuration	Press  to display.
F1	Interface Settings	Sets interface used for remote control.  Mainframe Remote Control 1.3 “Interface Settings”  3.4.2 “Interface Settings”
F2	Copy Settings	Sets screen hard copy.  3.4.3 “Copy Settings”
F3	System Settings	Turns on and off the buzzer sound and sets the reference frequency signal .  3.4.4 “System Settings”
F4	Application Switch Settings	Sets loading/unloading of applications.  3.4.5 “Application Switch Settings”
F5	System Information	Displays MS2830A system information.  3.4.6 “System Information”
F6	Option Information	Displays options installed in the MS2830A.  3.4.7 “Option Information”
F7	File Operation	Sets file and data management.  3.4.8 “File Operation”
F8	Close	Closes Configuration screen.
Page 2	Configuration	Press  , then press  to display.
F1	Software Install	Sets software and license installation.  3.4.9 “Software Install/Uninstall”
F6	Save&Recall Settings	Sets the mode for save and recall function.  3.6.4 “Simple Save&Recall”
F7	Correction	Sets settings related to Correction.  3.4.10 “Correction”
F8	Close	Closes Configuration screen.

3.4.2 Interface Settings

Pressing **F1** (Interface Settings) after **System Config** displays the Interface Settings screen. GPIB, Ethernet and USB interface conditions used for remote control can be set in this screen. Select the item to be set with the cursor, and then press **F7** (Set) to reflect the settings of that item.

Refer to Section 1.3 “Interface Settings” in the MS2690A/MS2691A/MS2692A and MS2830A Signal Analyzer Operation Manual (Mainframe Remote Control) for details.

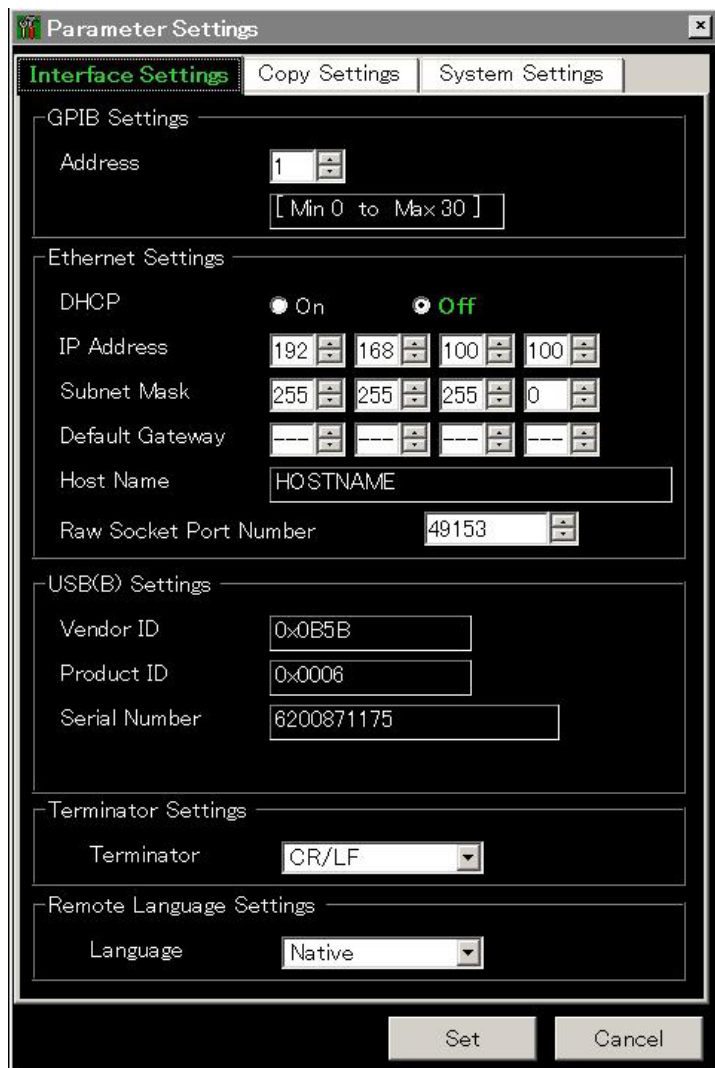

Figure 3.4.2-1 Interface Settings screen

3.4.3 Copy Settings

Pressing **F2** (Copy Settings) after **System Config** displays the Copy Settings screen. Screen hard copy conditions can be set in this screen. Select the item to be set with the cursor, and then press **F7** (Set) to reflect the settings of that item.

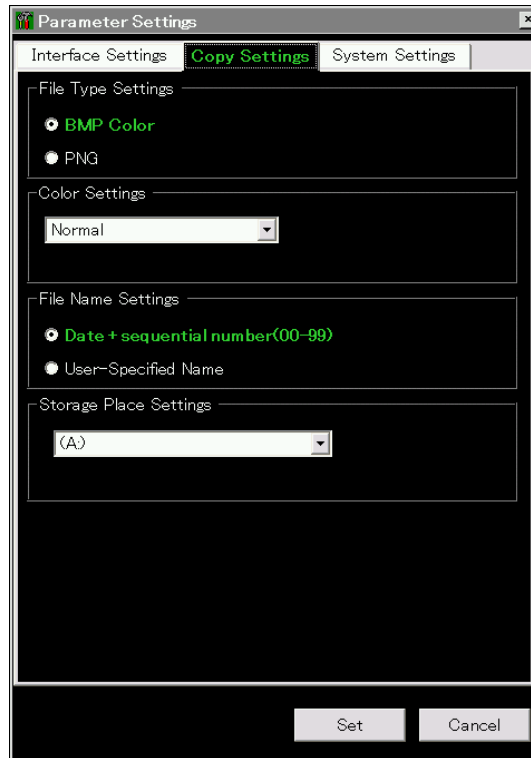



Figure 3.4.3-1 Copy Settings screen

Table 3.4.3-1 Copy Settings items

No.	Item	Description
<1>	File Type Settings	Selects the file format. BMP or PNG can be set.
<2>	Color Settings	Sets the screen hard copy color. Normal (same as screen display) or Reverse can be selected.
<3>	File Name Settings	The file naming method can be selected from auto (date + sequence number) or random. This setting is applied also to determining name for parameters and waveform data saving file.  3.6.1 "Saving parameters and waveform data"
<4>	Storage Place Settings	The file save location can be selected

3.4.4 System Settings

Pressing **F3** (System Settings) after **System Config** displays the System Settings screen. Select the item to be set with the cursor, and then press **F7** (Set) to reflect the settings of that item.

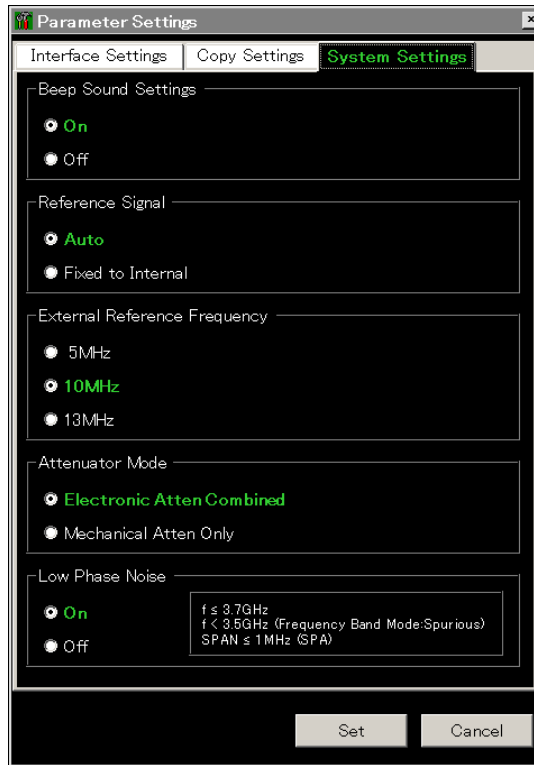

Figure 3.4.4-1 System Settings screen

Table 3.4.4-1 System Settings items

Item	Description
Beep Sound Setting	Sets the warning sound On/Off.
Reference Signal	<p>Selects the reference frequency signal type.</p> <p><u>Auto</u> Detects and automatically selects external reference signal input. Synchronizes the internal reference oscillator when an external input is not detected, and synchronizes to the external reference signal when an external input is detected.</p> <p><u>Fixed to Internal</u> Uses the internal reference oscillator.</p>

Table 3.4.4-1 System Settings items(Cont'd)

Item	Description
External Reference Frequency	Selects signal frequency, when using external reference signal as the signal source for reference frequency.
Attenuator Mode*1	Switches between Electronic attenuator (E-ATT) and Mechanical attenuator (M-ATT). *2 Electronic Atten Combined : Mostly uses E-ATT with partial use of M-ATT. Mechanical Atten Only : Exclusively uses M-ATT.
Low Phase Noise*3	Sets Low Phase Noise option On/Off (enable/disable) The setting range is displayed at the right side of the frame.

*1: This is displayed for MS2830A-040/041/043/044/045.

*2: The switching is made according to the table shown below.

*3: This is displayed when the MS2830A-062/066 Low Phase Noise Performance Option is installed.

Figure 3.4.4-1 is an example for other than Option 040. For Option 040, the setting range display is only for $\text{SPAN} \leq 1$ MHz (SPA).

Table 3.4.4-2 Attenuator Mode switching

Option	Frequency *4	Electronic Atten Combined	Mechanical Atten Only
040 041 043 044	≤ 6 GHz	0 to 10 dB → M-ATT 12 to 40 dB → E-ATT 42 to 60 dB → M-ATT	All M-ATT
	> 6 GHz	All M-ATT	All M-ATT
045	≤ 6 GHz*5	0, 10 dB → M-ATT*7 12 to 40 dB → E-ATT 50, 60 dB → M-ATT	All M-ATT
	> 6 GHz*6	All M-ATT	All M-ATT

*4: The following reference frequency is used:

Spectrum analyzer mode: STOP frequency

Signal analyzer mode: Center frequency

*5: Spurious Mode:

Stop frequency ≤ 4.1 GHz and Start frequency < 4 GHz

*6: Spurious Mode:

Stop frequency > 4.1 GHz or Start frequency ≥ 4 GHz

*7: Attenuator for 040/041/043/044 uses 2 dB step for both M-ATT and E-ATT

Attenuator for 045 uses 10 dB step for M-ATT and 2 dB step for E-ATT.

3.4.5 Application Switch Settings







Pressing  (Application Switch Settings) after  displays the Application Switch Settings function menu. The loading/unloading of applications can be set from this menu. Select the item to be set with the cursor, and then press  (Set) to display the setting window of that item or start performing the setting.

Table 3.4.5-1 Application Switch Settings items

Function Key	Menu Display	Function
F1	Load Application Select	Selects an application located in the Unloaded Applications frame to startup the selected application.  3.5.1 "Loading applications"
F2	Unload Application Select	Selects an application located in the Loaded Applications frame to end the selected application.  3.5.2 "Unloading applications"
F3	Position Change	Sets the loaded application anywhere on the Application Switch menu.  3.5.4 "Changing application layout"
F7	Set	Displays the setting window for the items selected by pressing F1, F2, or F3, or starts performing the setting.
F8	Close	Returns to the Configuration screen.

3.4.6 System Information









Pressing  (System Information) after  displays the System Information menu. The MS2830A system information can be viewed from this menu. Pressing the function key corresponding to the system information to be viewed displays the window of the selected item.

Table 3.4.6-1 System Information setting items

Function Key	Menu Display	Function
Page 1	System Information	Press  and then press  (System Information) to display.
F1	System Information View	Displays the MS2830A product type, serial number, operating time, and attenuator switching counts. ATT01: 2 dB (With MS2830A-045: No display) ATT02: 4 dB (With MS2830A-045: No display) ATT03: 8 dB (With MS2830A-045: No display) ATT04: 10 dB ATT05: 16 dB (With MS2830A-045: 30 dB) ATT06: 20 dB
F2	Software Version View	Displays the version of the software installed in the MS2830A.
F3	FPGA Version View	Displays the FPGA version for each board installed in the MS2830A.
F4	Board Revision View	Displays the revisions of each board installed in the MS2830A. (Some boards are not displayed.)
F5	Software License View	Displays the license of software installed in the MS2830A.
F6	SG Wave License View	Displays the license of SG waveforms installed in the MS2830A (only when a vector signal generator is installed).
Page 2	System Information	Press  , and then press  (System Information) to display.
F1	System Reset	Initializes the system.
F7	Information Save	Saves the MS2830A system information.

3.4.7 Option Information

Pressing  (Option Information) after  displays the option screen. Information on options installed in the MS2830A can be viewed in this screen.

3.4.8 File Operation





Pressing  (File Operation) after  displays the File Operation function menu. Data files can be managed from this menu. Pressing the function key corresponding to the data file to be managed displays the setting window of that item.

Table 3.4.8-1 Description of File Operation setting items

Function Key	Menu Display	Function
F1	Device (D:)	Selects drive.
F2	Parameter Save Data	Manages save data for parameter settings file.
F3	Copy Data	Manages copied file data.
F4	Trace Data	Manages trace data.
F5	Digitizer Data	Manages digitized data.
F7	System Information	Manages system information.

3.4.9 Software Install/Uninstall

Press , and then press  to move to page 2 of the Configuration function menu. Press  (Software Install) to display the Software Install menu. Software can be installed and uninstalled to/from the MS2830A from this menu. Pressing the function key corresponding to the item to be set executes the selected item.

Refer to Section 3.8 “Installing and Uninstalling” for details.

3.4.10 Correction

When making measurements with a spectrum analyzer, it may be necessary to correct the error and gain of the measurement system. The following are examples of them:

Frequency characteristics and loss of measurement cables

Frequency characteristics and loss of pre-amplifier, etc. connected to RF input connector.

When wanting to measure the field strength with an antenna or near-field probe connected (antenna factor correction).

In the cases above, Correction functions allow you to correct the error and gain.

You can input correction value via csv file or remote control operation. If inputting via csv file, refer to the Recall Correction Table. For details of remote command input, see “Correction Make Up” in Chapter 4 of the *MS2690A/MS2691A/MS2692A Signal Analyzer Operation Manual Mainframe Remote Control*.



Press , and then press  to move to page 2 of the Configuration function menu. Press  (Correction) to display the Correction function menu. Those functions are used to set correction factors for frequency characteristics.

Table 3.4.10-1 Correction Items

Function Key	Menu Display	Function
F1	Correction (On/Off)	Sets Correction to On/Off. When set to On, the level correction processing function is executed.
F2	Save Correction Table	Opens the Save Correction Table function menu.
F3	Recall Correction Table	Opens the Recall Correction Table function menu.
F8	Close	Returns to the Configuration menu.

Pressing  (Save Correction Table) on Correction function menu displays Save Correction Table function menu. Those functions are used to save level frequency characteristics.

Table 3.4.10-2 Items of Save Correction Table

Function Key	Menu Display	Function
F1	Device (D:)	Selects the drive.
F7	Save Correction Table	Saves the level frequency characteristics. When File Name Setting is set to Data + sequential, the file is automatically named "Corr date_sequential number". The file is in CSV format and is saved in "[Selected drive]:\Anritsu Corporation\Signal Analyzer\User Data\Corrections\". Up to 1000 files can be saved in the folder.
F8	Close	Returns to the Configuration menu.

Pressing  (Recall Correction Table) on Correction function menu displays the Recall Correction Table function menu. Those functions are used to recall the saved level frequency characteristics.

Table 3.4.10-3 Items of Recall Correction Table

Function Key	Menu Display	Function
F1	Device (D:)	Selects the drive.
F7	Recall Correction Table	Recalls the level frequency characteristics. A file is in CSV format.
F8	Close	Returns to the Configuration menu.

A Correction file is in CSV format, as shown below. Signal levels can be corrected by sets of frequency and level in the Correction file. Also, the correction factors between Fa and Fb are calculated by the linear interpolation of log value at Fa and Fb.

```
Frequency(Hz),Level(dB)
0,0
980000000,1
1000000000,4
1200000000,1
```

Describe the frequency and level to be corrected within the following range for the CSV file.

Up to 4096 items of correction data can be set.

[Frequency]

Range -1 to 400 GHz

Resolution 1 Hz

Set the unit in Hz.

[Level]

Range -100 to 100 dB

Resolution 0.001 dB

As shown in Figure 3.4.10-4, if the frequency range over which the correction factors are entered is from F_a to F_b , displayed frequency ranges lower than F_a or higher than F_b have correction factors applied. The correction factor for frequencies lower than F_a is the same as that (L_a) for F_a and the correction factor for frequencies higher than F_b is the same as that (L_b) for F_b . The correction factors between F_a and F_b are calculated by the linear interpolation of log value at F_a and F_b .

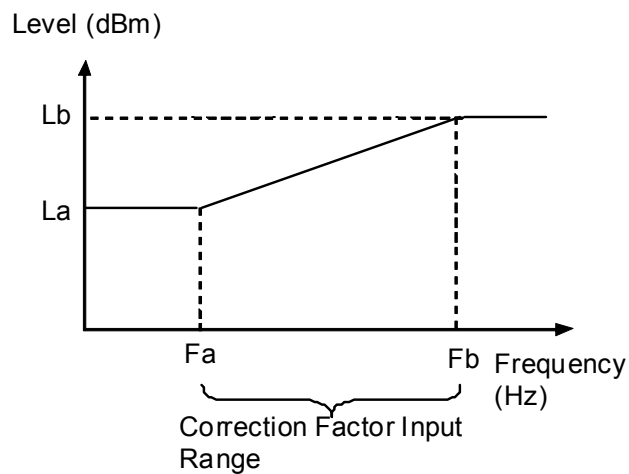

Figure 3.4.10-4 Operation When Correction Factors Are Entered

Correction factors apply to all the applications other than Signal Generator.

In Signal Analyzer functions, the correction factors of the center frequency are applied to all the trace data in the same span.

Executing the following functions initializes the correction factors.
Installing application software does not initialize the correction factors.

To execute System Reset.

To execute the system recovery functions.

3.5 Loading, Unloading, and Switching Applications

The following describes the procedures for loading, unloading and switching applications (signal analyzer, spectrum analyzer, etc).

Loading applications refers to the setting of applications already installed to an execution state. Loaded applications are registered to the Application Switch menu and are in an operable state. In addition, these applications enter an execution state when the power is turned On after registration. At the factor default, all applications are installed thus in “loaded” state. However, application in excess of maximum number of loadable applications is listed as “Unloaded”.

Unloading applications refers to the halting and ending of applications in an execution state. Unloaded applications are released from Application Switch menu registration and will not run until they are re-loaded.

Switching applications refers to the operation for selecting the applications to be operated from the applications in an execution state. You can select the target applications from the Application Switch menu.

CAUTION

- 1. Applications registered to the Application Switch menu automatically enter an execution state when starting up the MS2830A. The more registered applications, the longer startup will take.**
 - 2. In the event running applications are suddenly ended while operating Windows, press , turn the MS2830A power Off or shutdown Windows, and then turn the MS2830A power On again.**
 - 3. When many applications are running simultaneously and the measurement software calls a measurement function from the signal or spectrum analyzer functions, sometimes the application may take a long time to switch. Reducing the number of simultaneously running applications by unloading them will help prevent this problem.**
-

3.5.1 Loading applications

Applications can be loaded from the Configuration screen.

<Procedure>

1. After pressing **System Config**, press **F4** (Application Switch Settings) to display the Application Switch Registration screen.
2. Press **F1** (Load Application Select), select the applications to be loaded from the applications displayed in “Unloaded Applications” at the bottom part of the screen, and then press **F7** (Set). Press **F1** (Load Application Select) once again, when an error message “Loading application failed” is displayed.

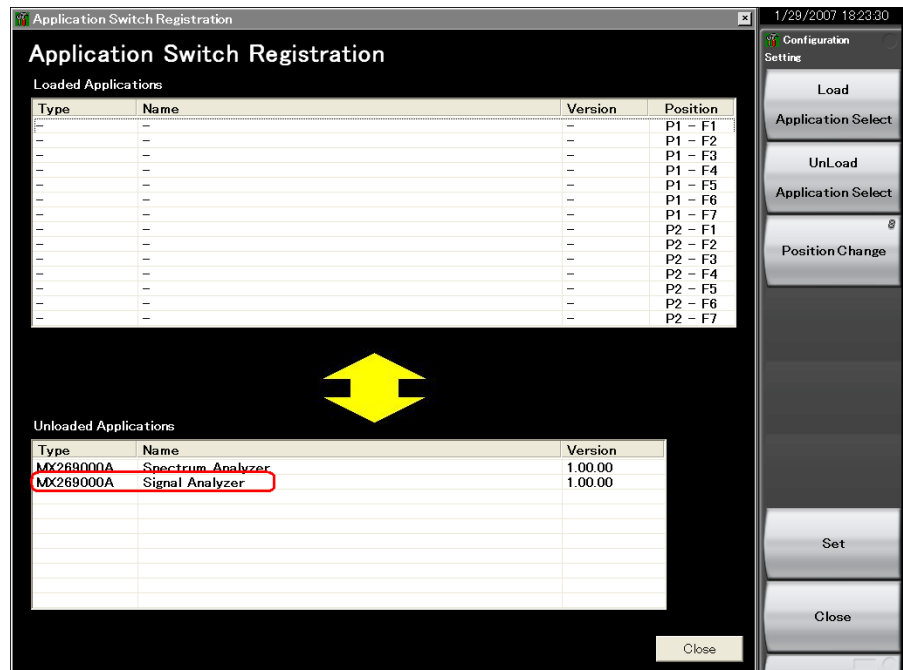
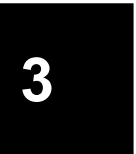

Figure 3.5.1-1 Application Switch Registration screen

- When registered correctly, the selected applications will be displayed in “Loaded Applications” at the top part of the screen.

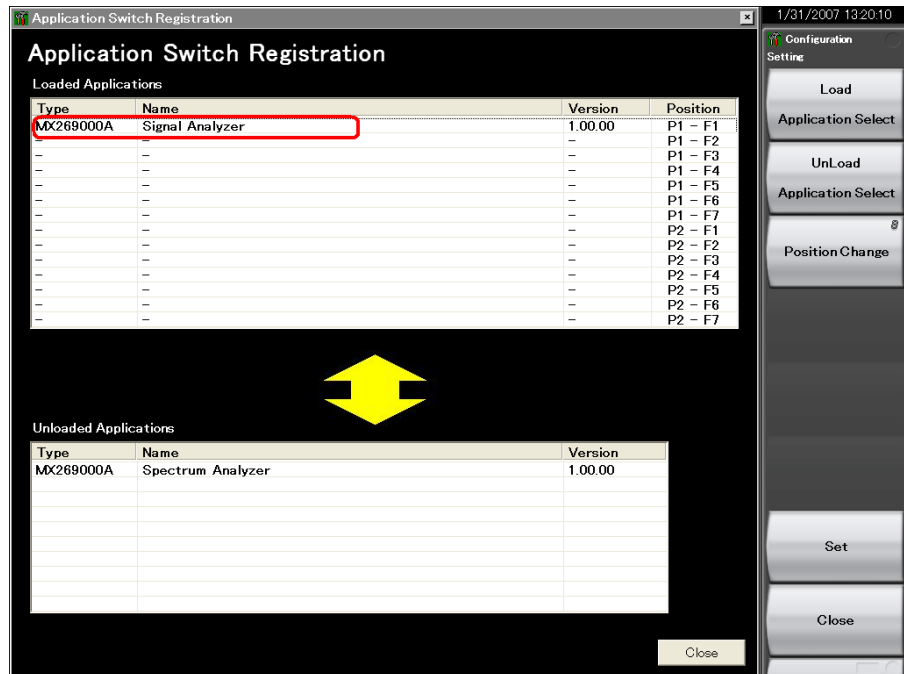

Figure 3.5.1-2 Application Switch Registration screen

- Press  to display the Application Switch menu. Check that the loaded application is displayed in the menu. Select the application with the function key to operate the application.







Figure 3.5.1-3 Application Switch Menu screen

3.5.2 Unloading applications

Applications can be unloaded from the Configuration screen.

<Procedure>

1. After pressing , press  (Application Switch Settings) to display the Application Switch Registration screen.
2. Press  (Unload Application Select), select the application to be unloaded from the applications displayed in “Loaded Applications” at the top part of the screen with the cursor, and then press  (Set).

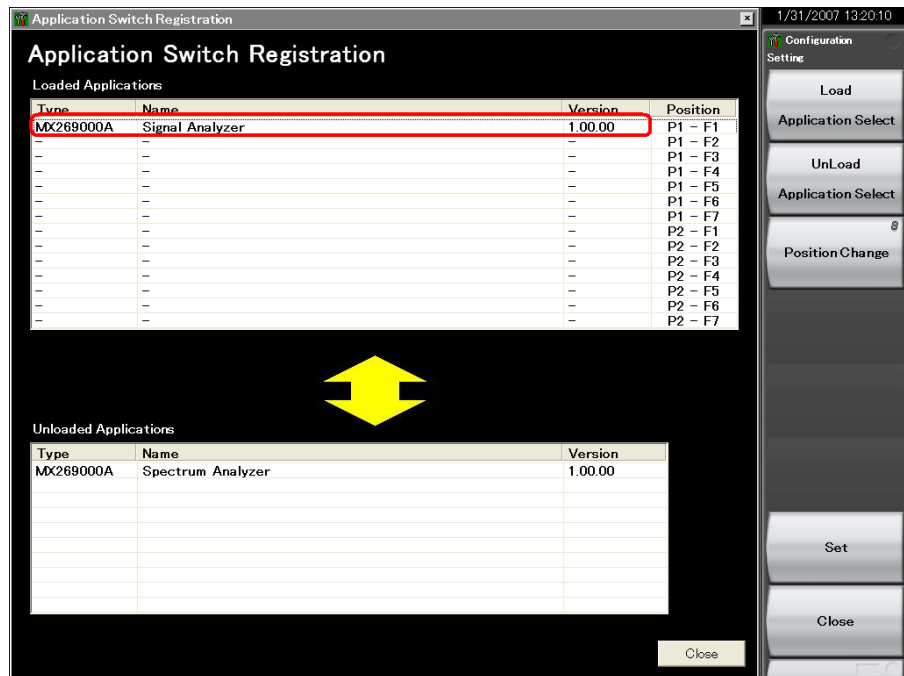

Figure 3.5.2-1 Application Switch Registration screen

- 3. When ended correctly, the selected applications will be displayed in “Unloaded Applications” at the bottom part of the screen.

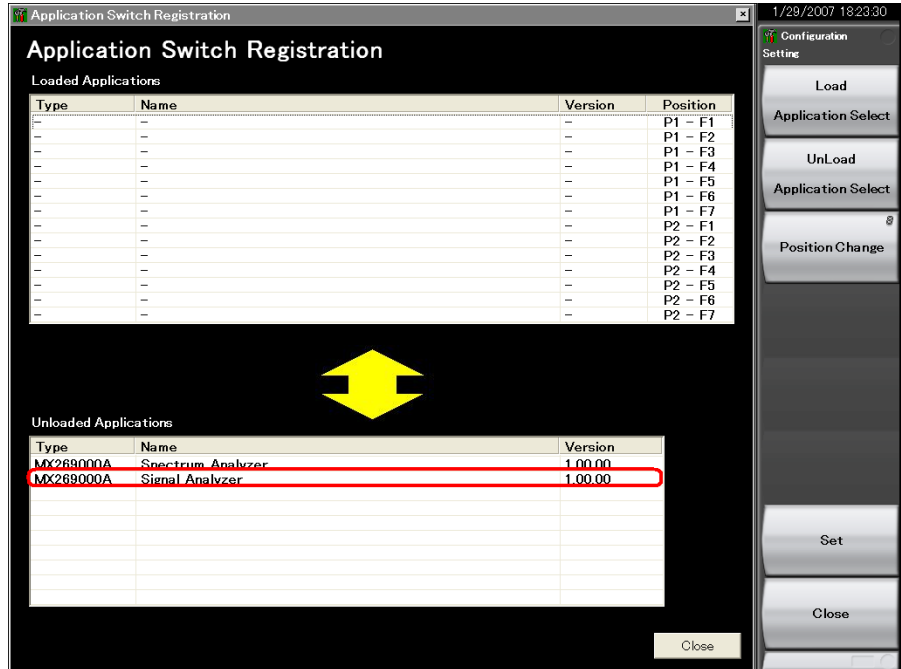



Figure 3.5.2-2 Application Switch Settings screen

3.5.3 Switching applications

Applications to be operated can be switched in the Application Switch menu.

Pressing  displays the Application Switch menu screen. Pressing the function key corresponding to the application switches to the selected application screen.

If the Application (Auto/Manual) setting is set to Auto as explained in “3.5.4 Changing application layout”, the application you selected above is assigned. From the next time on, you can call up the application by only pressing .





Figure 3.5.3-1 Application Switch menu

3.5.4 Changing application layout

The layout of applications can be changed as desired in the Application Switch menu. Set the application layout in the Configuration screen.

<Procedure>

1. After pressing , press  (Application Switch Settings) to display the Application Switch Registration screen.
2. Press  (Position Change) to display the Application Switch Function Position Edit screen. The Setting function menu is also displayed.

Note:

The arrangement in the Function Position area is the arrangement of the function keys displayed according to the Application Switch key.

The arrangement in the Application Key area is the same as the Application Key arrangement.

Table 3.5.4-1 Setting function menu description

Function Key	Menu Display	Function
F1	Application (Auto/Manual)	<p>Auto: The setting of Application Key slot 5 is performed automatically, and an application is assigned to the Appli key automatically.  3.5.3 "Switching applications"</p> <p>Manual: The setting of Application Key slot 5 is performed manually, and the assignment of an application to the Appli key is fixed.</p>
F7	Set	Finalizes the assignment of applications.
F8	Cancel	Returns to the Configuration screen.

3. In the Function Position field, select the application whose layout is to be changed with the cursor, and then press .

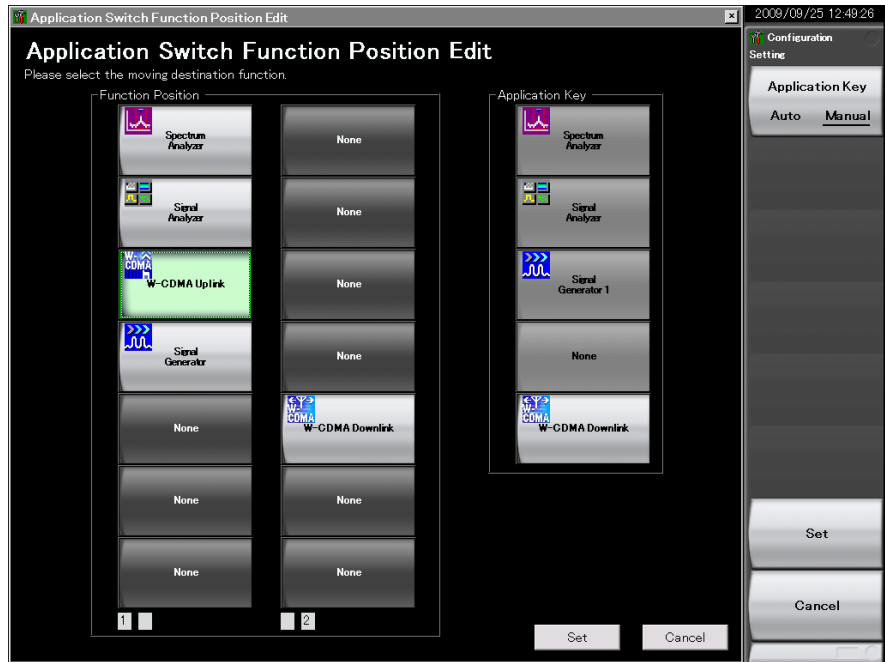



Figure 3.5.4-1 Application Switch Function Position Edit screen

4. Select the new position from the slots in the Function Position area or slot 5 in the Application Key area using the cursor keys and press .

Note:

Slots 1, 2, and 3 in the Application Key area are automatically assigned to the Spectrum Analyzer, Signal Analyzer, and Signal Generator applications in accordance with the application key display on the front panel. Slot 4 is not used.

Any application can be set for slot 5 and assigned to the Appli key.

5. After checking that the application is placed in the selected position, press  (Set).

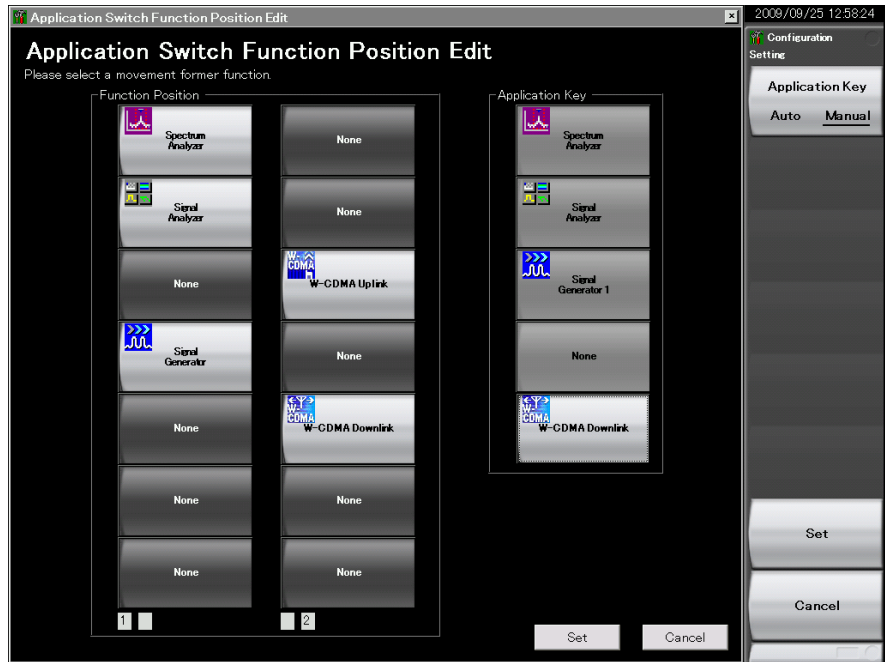

Figure 3.5.4-2 Application Switch Function Position Edit screen

3.6 Save and Recall Functions

This section describes the conditions for setting parameters to the internal hard disk and USB memory (Parameter) and saving (Save) and recalling (Recall) of waveform data (Trace).

Note:





Use the USB memory supplied with the MS2830A. Using other USB memories may cause malfunction due to device incompatibility.

3.6.1 Saving parameters and waveform data

With the MS2830A, the current setting conditions and waveform data can be saved to the internal hard disk or a USB memory.

Saving parameter settings

<Procedure>

1. Press  from the Configuration screen, Signal Analyzer screen, or Spectrum Analyzer screen to display the Save function menu shown in Table 3.6.1-1.
2. Press  (Device) to change the save destination. When the Setting window is displayed, select the drive to be saved and then press  (Set) to set.
3. When the save destination has been determined, press  (Save Application). The save target will be all parameter setting conditions (Parameter) of the launched applications.

The parameter saving file will be output with the name “Param_date_sequential number.xml.” If a parameter is saved on the same date, the file is automatically named in the order “Param_date_000.xml,” “Param_date_001.xml,” “Param_date_002.xml” and so on. Parameter saves of up to “Param_date_999.xml” can be made.

A sequential number from 000 to 999 will be added to the file name.

To specify the file name, set User Specified Name in File Name Settings in Copy Settings. The parameter saving file name can be specified when saving.

 3.4.3 “Copy Settings”

Files will be saved in the following directory of the save target drive specified in  (Device).

\Anritsu Corporation\Signal Analyzer\User Data\Parameter Setting

Up to 1000 files can be saved in the folder.

Saving waveform data

<Procedure>





1. Press  from the Signal Analyzer and Spectrum Analyzer screen to display the Save function menu shown in Table 3.6.1-1.
2. Press  (Device) to change the save destination. When the Setting window is displayed, select the drive to be saved and then press  (Set) to set.
3. When the save destination has been determined, press  (Save Waveform CSV DATA). The save target will be the waveform data (Trace).

Table 3.6.1-1 Description of Save function menu

Function Key	Menu Display	Function
F1	Device (D:)	Changes the saving destination.
F5	Save Waveform CSV DATA	Saves the displayed waveform data (Trace).
F7	Save Application	Saves the parameter setting conditions of all the launched applications.
F8	Close	Returns to the Configuration screen.

A sequential number from 00 to 99 will be added to the file name. If a file with file number 99 is used, no more files can be saved.

To specify the file name, set User Specified Name in File Name Settings in Copy Settings. The waveform data file name can be specified when saving.

 3.4.3 “Copy Settings”

Files will be saved in the following directory of the save target drive specified in  (Device).

\Anritsu Corporation\Signal Analyzer\User Data\Trace Data

The maximum number of files in one folder is:

Signal Analyzer: 1000

Spectrum Analyzer: 100

3.6.2 Recalling parameters

With the MS2830A, settings can be restored by loading saved setting conditions from the internal hard disk or a USB memory.

Recalling parameter setting conditions only of applications to be operated using Application Switch

<Procedure>

1. Press **Recall** from the Configuration, Signal Analyzer, or Spectrum Analyzer screen to display the Recall function menu shown in Table 3.6.2-1.
2. Press **F1** (Device) to change the location of saved parameter setting conditions. When the Setting window is displayed, select the drive in which parameter setting conditions are saved, and then press **F7** (Set) to set.
3. Press **F6** (Recall Current Application) to display the Parameter Save Data List.
4. Select the parameter setting conditions to be recalled with the cursor, and then press **F7** (Set) to recall parameter setting conditions to the application.

Recalling parameter setting conditions for all launched applications.

<Procedure>





1. Press  from the Configuration, Signal Analyzer or Spectrum Analyzer screen to display the Recall function menu shown in Table 3.6.2-1.
2. Press  (Device) to change the location of saved setting parameters. When the Setting window is displayed, select the drive in which setting parameters are saved, and then press  (Set) to set.
3. Press  (Recall All Application) to display the Parameter Save Data List.
4. Select the parameter setting conditions to be recalled with the cursor, and then press  (Set) to recall the parameter setting conditions to all loaded applications.

Table 3.6.2-1 Recall Menu Items

Function Key	Menu Display	Function
F1	Device (D:)	Changes the saving destination.
F6	Recall Current Application	Displays the Parameter Save Data List. This function is used to recall the parameter setting conditions of only the current application.
F7	Recall all Application	Displays the Parameter Save Data List. This function is used to recall the parameter setting conditions of all the loaded applications.
F8	Close	Returns to the Configuration screen.

3.6.3 Screen hard copy

A displayed screen image can be saved to the internal hard disk or a USB memory as a BMP or PNG formatted file.

The conditions for copying a screen image can be set in the Copy Settings screen. Refer to the following section for details.

 3.4.3 “Copy Settings”

Executing screen hard copy

<Procedure>

1. Display the screen to be saved.
2. Press  to save the screen image to the selected media in BMP or PNG format. A saved file name is displayed when saving is completed.

The image file will be output with the file name “Copy_Date_Sequence_Number.bmp”. When screen hard copies are made on the same date, they are automatically named in an order as “Copy_Date_000.bmp”, “Copy_Date_001.bmp”, “Copy_Date_002.bmp”, and so on. Screen hard copies of up to “Copy_Date_999.bmp” can be made. A sequential number from 000 to 999 will be added to the file name.

Files will be saved in the following directory of the save target drive specified in  (Device).

\Anritsu Corporation\Signal Analyzer\User Data\Copy Files



Up to 1000 files can be saved in the folder.

3.6.4 Simple Save&Recall

This function allows parameter setting conditions to be recalled with little operations.

Enabling Simple Save&Recall

<Procedure>

1. Press  to display the Configuration screen.
2. Press  to display page 2 of the Configuration menu.
3. Press  (Save&Recall Settings) to display the Save&Recall Settings menu in Figure 3.6.4-1.

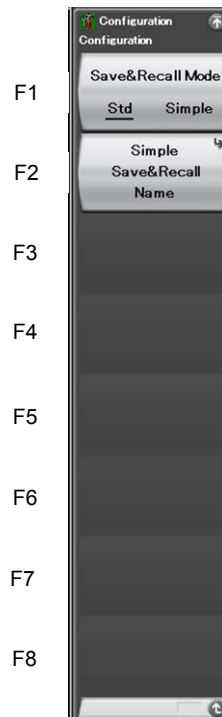



Figure 3.6.4-1 Save&Recall Settings menu

Table 3.6.4-1 Correction Settings items

Menu Display	Description
Save&Recall Mode	Switches the Save&Recall mode. Set the Standard mode or Simple mode.  3.6.1 "Saving parameters and waveform data"  3.6.2 "Recalling parameters"
Simple Save&Recall Name	Use this item to change the parameter name (file name) to be saved from the default setting in Simple mode.

Changing the parameter name (file name) to be saved from the default setting

Pressing **F2** (Simple Save&Recall Name) in Figure 3.6.4-1 displays the Simple Save&Recall Name menu in Figure 3.6.4-2. Up to ten parameter names can be registered in Simple mode.

The default parameter names are PRM_1 to PRM_10.

To change the parameter name, press the function key to be changed.

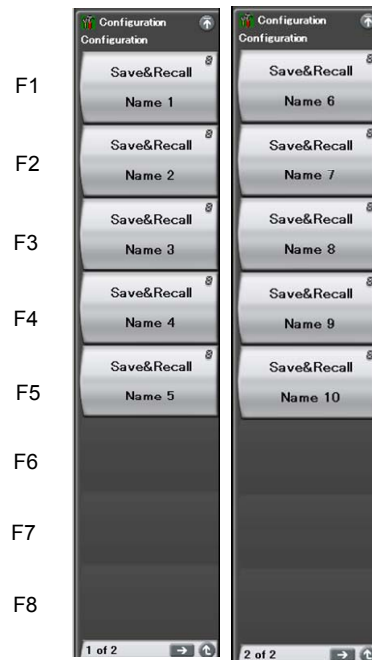



Figure 3.6.4-2 Simple Save&Recall Name menu

Simple Save function

Pressing  in Simple mode displays the Simple Save menu in Figure 3.6.4-3.

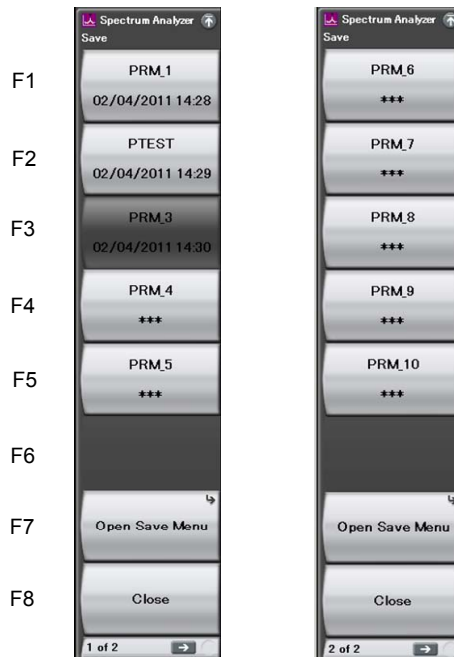

Figure 3.6.4-3 Simple Save menu

Parameter names set with the Simple Save&Recall Name menu are displayed on the function keys.

When the Protect of the parameter saving file has been set to On (when set to Read-only), the relevant function key is grayed out, and if it is pressed, an error message is displayed.

The last saved date and time of the parameter saving file is displayed in the second line. If the corresponding parameter saving file does not exist, “***” is displayed on the function key.

In the example in Figure 3.6.4-3, the parameter name of PRM_2 has been changed to the parameter name of PTEST. Also, PRM_3 file has been set to Read-only.

Pressing the function key stores the parameter saving file with the parameter name displayed.

\\Anritsu Corporation\\Signal Analyzer\\User Data\\Parameter Setting

The parameter settings can be saved in Standard mode on Open Save Menu.

 3.6.1 “Saving parameters and waveform data”

Simple Recall function

Pressing  in Simple mode displays the Simple Recall menu in Figure 3.6.4-4.

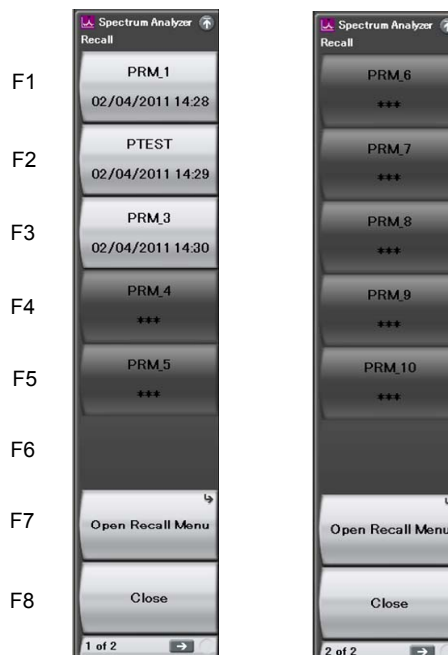

Figure 3.6.4-4 Simple Recall menu

Parameter names set with the Simple Save&Recall Name menu are displayed on the function keys.

The last saved date and time of the parameter saving file is displayed in the second line.

Pressing the function key executes Recall of the corresponding parameter saving file.

If the corresponding parameter saving file does not exist, the function key is grayed out, and if it is pressed, an error message is displayed.

The parameter settings can be recalled in Standard mode on Open Recall Menu.

 3.6.2 “Recalling parameters”

3.7 Initializing

This section describes how to initialize settings.

3.7.1 Preset

Preset is a function for initializing application settings. Configuration screen settings are not initialized using this function. Similarly, there is no effect on user data saved to the internal hard disk.

<Procedure>



1. Press  to display the Preset function menu.
2. Press  (Preset) to initialize only applications to be operated using the Application Switch.
3. Press  (Preset All Application) to initialize all loaded applications.

Table 3.7.1-1 Preset function menu items

Function Key	Menu Display	Function
F1	Preset	Initializes only the application subject to operation by the Application Switch.
F5	Preset All Application	Initializes all the loaded applications.
F6	Reboot	Restarts the equipment.
F8	Close	Closes the current menu screen and returns to the Configuration screen.

3.7.2 System Reset

System Reset is a function for initializing all installed applications and Configuration screen settings, and deleting all user data saved to the internal hard disk.

Note:

User data deleted by executing this function cannot be recovered.

<Procedure>







1. Press  to display the Configuration screen.
2. Press  (System Information) and then press  to display page 2 of the System Information menu.
3. Press  (System Reset) to execute System Reset.
4. The MS2830A restarts automatically when System Reset is completed.

Table 3.7.2-1 System Information Function Menu Items (2/2)

Function Key	Menu Display	Function
Page 2	System Information	Pressing  , then  , and then  displays page 2 of the System Information menu.
F1	System Reset	Initializes all the installed applications and the Configuration screen settings, and erases all the user data saved on the internal hard disk. Erased user data cannot be recovered.
F7	Information Save	Saves the system information

3.8 Installing and Uninstalling

This section describes the procedure for installing application software and licenses.

3.8.1 Installing software

Preparation for installing USB memory

<Procedure>

1. Connect the USB memory to the PC, and then insert the installation disk.
2. Select MS2830A Install from Install Software on the installation menu.
3. Specify the root directory of the connected USB memory on the installation directory specification window (e.g., “E:\” when the USB memory is drive E).
4. Click **OK** to copy the installation data into the USB memory. The installation data is copied into the “E:\Anritsu Corporation\Signal Analyzer\Install” folder, when the USB memory is drive E.
Set the same folder configuration before the installation, in order to manually install by copying a set of the installation files in the USB memory and drive D.

Installing software

<Procedure>

1. Remove the peripheral devices from the USB ports of the MS2830A, other than mouse and keyboard.
2. Press **System Config** to display the Configuration screen, and then press **F1** (Software Install) from page 2 of the Configuration function menu.
3. The Software Install menu shown in Figure 3.8.1-1 is displayed. Press **F1** (Install).
4. The installation selection menu is displayed. Insert the USB memory containing the purchased software data into the USB port of the MS2830A.

Note:

Do not insert any devices other than USB memory to the USB ports during installation.

5. Press **F1** (Software) to display the device selection window.
6. Select the USB memory device containing the software with the cursor, and then press **F7** (Set) to start the installation.
7. The MS2830A restarts automatically when the installation is completed.

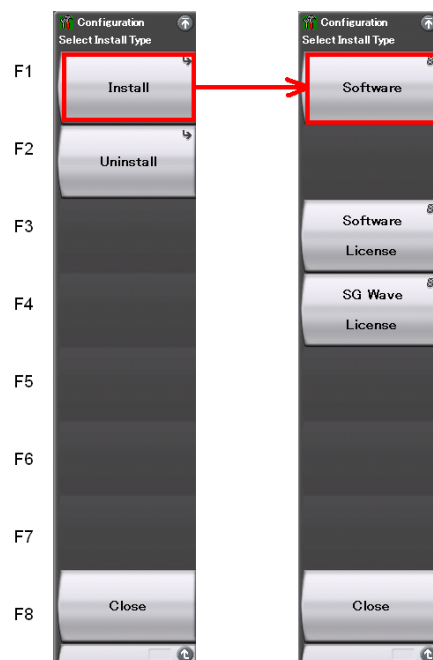







Figure 3.8.1-1 Software Install menu

Installing software licenses

<Procedure>

1. Press  to display the Configuration function screen, and then press  (Software Install) from page 2 of the Configuration menu.
2. The Software Install menu shown in Figure 3.8.1-2 is displayed. Press  (Install).
3. The installation selection menu is displayed. Insert the USB memory containing the purchased software license data into the USB port of the MS2830A.
4. Press  (Software License) to display the device selection window.
5. Select the USB memory device containing the software license with the cursor, and then press  (Set) to start the installation.
6. The license becomes valid when the MS2830A is restarted after installation is completed.

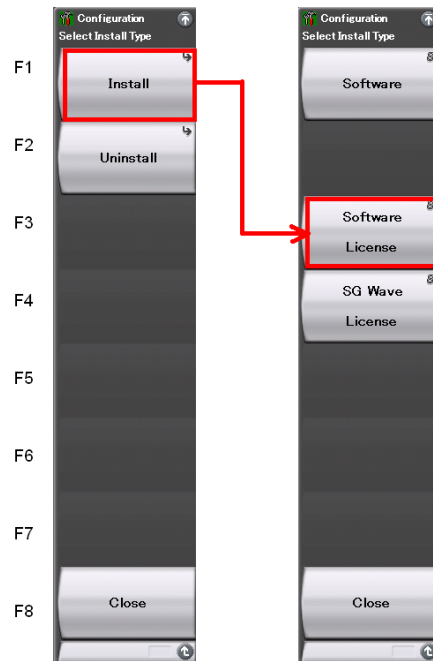

Figure 3.8.1-2 Software Install menu

Installing waveform pattern licenses

<Procedure>

1. Press **System Config** to display the Configuration screen, and then press **F1** (Software Install) from page 2 of the Configuration menu.
2. The Software Install menu shown in Figure 3.8.1-3 is displayed. Press **F1** (Install).
3. The installation selection menu is displayed. Insert the USB memory containing the purchased software license data into the USB port of the MS2830A.
4. Press **F4** (SG Wave License) to display the device selection window.
5. Select the USB memory device containing the software license with the cursor, and then press **F7** (Set) to start the installation.
6. The license will be valid when the MS2830A is restarted after installation is completed.

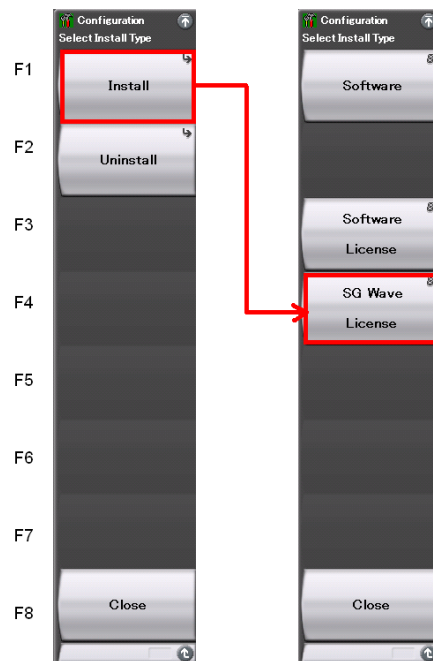

Figure 3.8.1-3 Software Install menu

3.8.2 Uninstalling software

The Install screen must be displayed in order to uninstall software or license files from the MS2830A.

Uninstalling software

<Procedure>

1. Press **F1** (System Config) to display the Configuration screen, and then press **F1** (Software Install) from page 2 of the Configuration menu.
2. The Software Install menu shown in Figure 3.8.2-1 is displayed. Press **F2** (Uninstall).
3. The installation selection menu is displayed. Press **F1** (Software).
4. The installed software list screen is displayed. Select the software to be uninstalled from the installed software with the cursor.
5. Press **F3** (Uninstall) to start uninstalling.

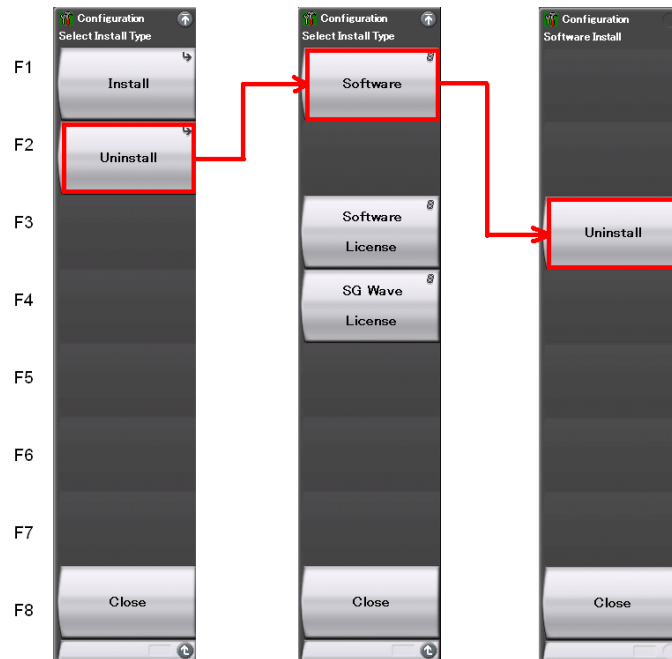

Figure 3.8.2-1 Software Install menu

Uninstalling software licenses

<Procedure>

1. Press **F1** (System Config) to display the Configuration screen, and then press **F1** (Software Install) from page 2 of the Configuration menu.
2. The Software Install menu shown in Figure 3.8.2-2 is displayed. Press **F2** (Uninstall).
3. The installation selection menu is displayed. Press **F3** (Software License).
4. The installed software license list screen is displayed. Select the software license to be uninstalled from the installed software licenses with the cursor.
5. Press **F3** (Uninstall) to start uninstalling.

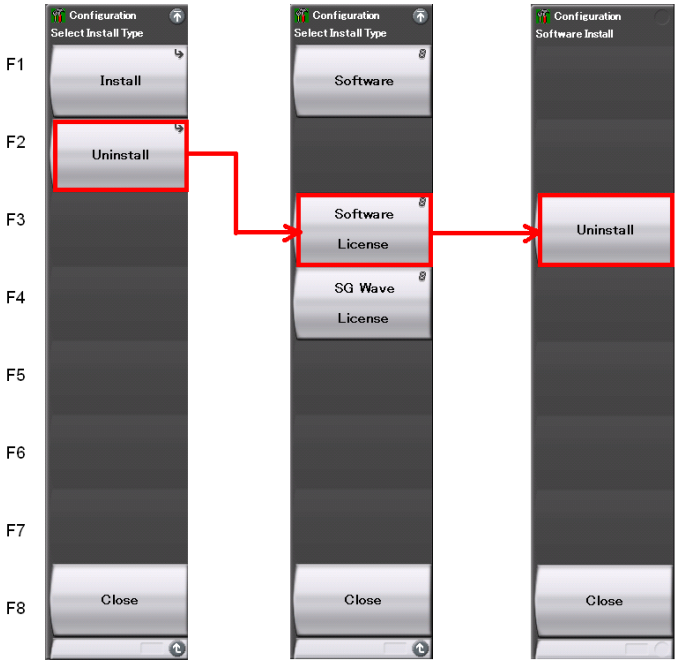

Figure 3.8.2-2 Software Install menu

Uninstalling waveform pattern licenses

<Procedure>

1. Press **F1** (System Config) to display the Configuration screen, and then press **F1** (Software Install) from page 2 of the Configuration menu.
2. The Software Install menu shown in Figure 3.8.2-3 is displayed. Press **F2** (Uninstall).
3. The installation selection menu is displayed. Press **F4** (SG Wave License).
4. The installed software license list screen is displayed. Select the software license to be uninstalled from the installed software licenses with the cursor.
5. Press **F3** (Uninstall) to start uninstalling.

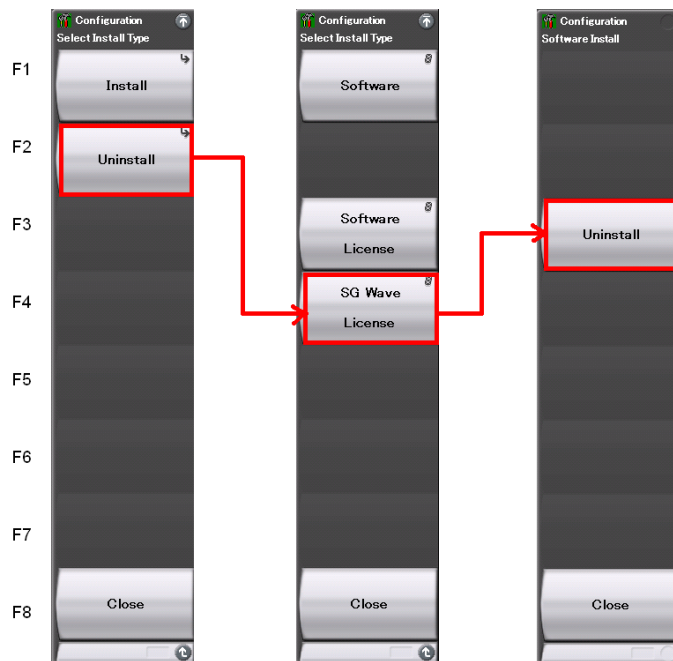

Figure 3.8.2-3 Software Install menu

Chapter 4 Tutorial

This chapter describes the waveform display of the signal analyzer and spectrum analyzer.

4.1	Spectrum Analysis Using Signal Analyzer.....	4-2
4.1.1	Spectrum analysis	4-2
4.2	Spectrum Analysis Using Spectrum Analyzer	4-6
4.2.1	Spectrum Analysis.....	4-6

4.1 Spectrum Analysis Using Signal Analyzer

Option 006/106 is required to use the signal analyzer function.

4.1.1 Spectrum analysis

The section describes the operation procedure for displaying input signal waveforms to the application screen of the signal analyzer.



Figure 4.1.1-1 Front panel

Example: Input Signal: Frequency: 1 GHz (CW)
Level: -10 dBm

<Procedure>

1. Connect the input signal to the RF Input (N-type connector) on the front panel of the MS2830A.
2. Press **System Config** then **F4** (Application Switch Settings) to display the Application Switch Settings menu.
3. Press **F1** (Load Application Select) to select within the “Unload Applications” column of the application with the cursor. Select “Signal Analyzer” here with the cursor, and then press **F7** (Set).
4. Check that “Signal Analyzer” is displayed within the “Loaded Applications” column then press **Application Switch**.
5. Pressing the function key corresponding to the Signal Analyzer from the Application Switch Settings menu displays the application main screen of the Signal Analyzer.



Figure 4.1.1-2 Application main screen

Table 4.1.1-1 Display items for Signal Analyzer

Item	Description
[1]	This is the main function key of the signal analyzer. Basic parameter settings of the signal analyzer are configured here. Signal Analyzer Function Operation ☞ 2.1 “Display Description”
[2]	Displays signal waveforms.
[3]	Displays the center frequency, frequency span and other frequency parameters. Signal Analyzer Function Operation ☞ 2.2 “Setting Frequency”
[4]	Displays the reference level, input attenuator value and other level parameters. Signal Analyzer Function Operation ☞ 2.3 “Setting Level”
[5]	Displays the trigger source, trigger level and other trigger parameters. Signal Analyzer Function Operation ☞ 3.2 “Trigger Function”
[6]	Displays the start frequency. Signal Analyzer Function Operation ☞ 2.2.3 “Setting start frequency”
[7]	Displays the stop frequency. Signal Analyzer Function Operation ☞ 2.2.4 “Setting stop frequency”
[8]	Displays the analysis start time, analysis time span, resolution bandwidth and other Spectrum trace parameters. Signal Analyzer Function Operation ☞ 4.2.1 “What is Spectrum trace?”
[9]	Displays marker values. Signal Analyzer Function Operation ☞ 4.2.9 “Setting marker search”
[10]	This is used as an indicator expressing an analysis progression rate.

- Frequency settings must be changed to display the input signal in the waveform display screen. Press **F1** (Frequency).
- Press **F1** (Center Frequency) and then enter the desired frequency using the numeric keypad. The center frequency setup window is displayed.

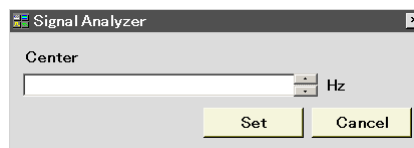

Figure 4.1.1-3 Center frequency setup window

8. Enter the center frequency then select the unit, from GHz, MHz, kHz, and Hz.

Example: To set 1 GHz for the center frequency, press **1** and then **F1** (GHz).

The waveform of the input signal is now displayed on the screen (see Figure 4.1.1-4).

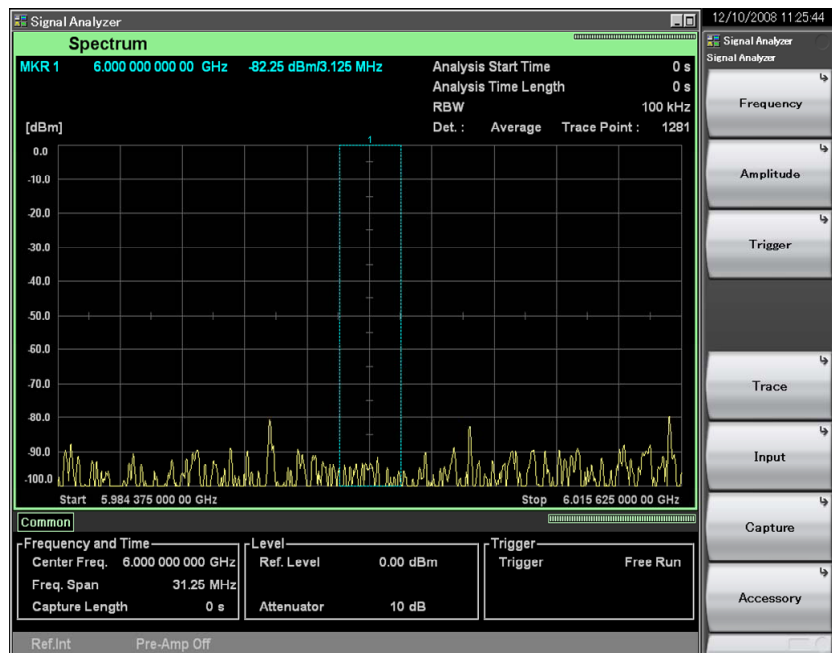

Figure 4.1.1-4 Waveform display using Signal Analyzer

Refer to the “MS2830A Signal Analyzer Operation Manual (Signal Analyzer Function Operation)” for how to use the Signal Analyzer.

4.2 Spectrum Analysis Using Spectrum Analyzer

4.2.1 Spectrum Analysis





This section describes the operation procedure for displaying input signal waveforms to the application screen of the spectrum analyzer.



Figure 4.2.1-1 Front panel

Example: Input Signal: Frequency: 1 GHz (CW)
Level: -10 dBm

<Procedure>

1. Connect the input signal to the RF Input (N-type connector) on the front panel of the MS2830A.
2. Press  then  (Application Switch Settings) to display the Application Switch Settings menu.
3. Press  (Load Application Select) to select within the “Unload Applications” column of the application with the cursor. Select “Spectrum Analyzer” here with the cursor, and then press  (Set).
4. Check that “Spectrum Analyzer” is displayed within the “Loaded Applications” column then press .
5. Pressing the function key corresponding to the Spectrum Analyzer from the Application Switch Settings menu displays the application main screen of the Spectrum Analyzer.

The application is shipped already loaded.

The application is set to start automatically at power startup.

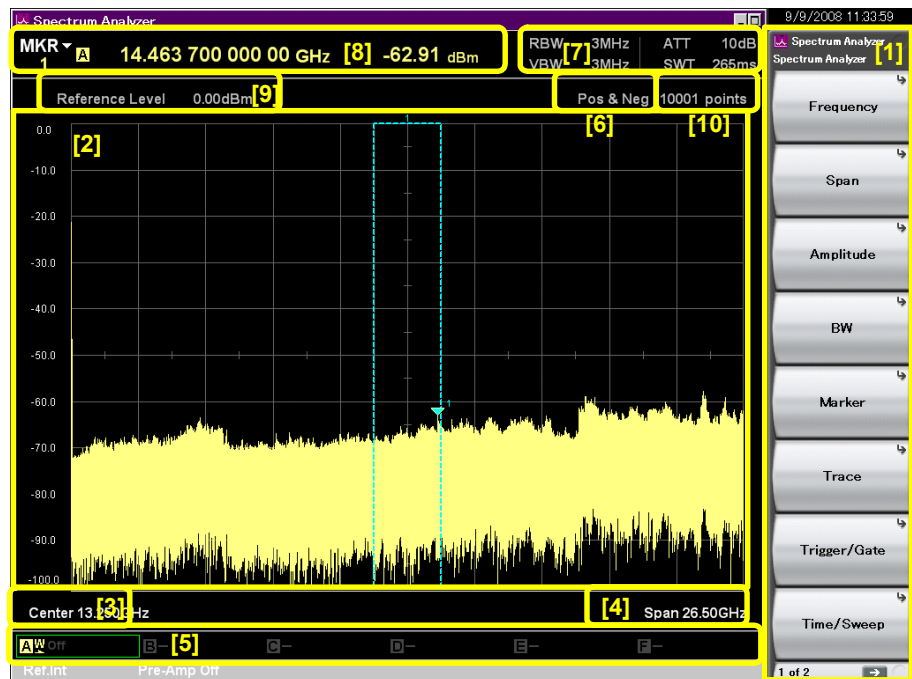

Figure 4.2.1-2 Application main screen

Table 4.2.1-1 Display items for Spectrum Analyzer

Item	Description
[1]	This is the main function key of the spectrum analyzer. Basic parameter settings of the spectrum analyzer are configured here. Spectrum Analyzer Function Operation ☞ 2.1 “Display Description”
[2]	Displays signal waveforms.
[3]	Displays the start frequency. Spectrum Analyzer Function Operation ☞ 2.3.3 “Setting start frequency”
[4]	Displays the stop frequency. Spectrum Analyzer Function Operation ☞ 2.3.4 “Setting stop frequency”
[5]	Displays trace parameters. Spectrum Analyzer Function Operation ☞ Chapter 3 “Selecting Display Mode”
[6]	Displays the wave detection mode status. Spectrum Analyzer Function Operation ☞ 3.1.4 “Setting wave detection mode”
[7]	Displays the resolution bandwidth, video bandwidth, input attenuator and sweep time parameters. Spectrum Analyzer Function Operation ☞ 2.4.2 “Setting input attenuator” ☞ 2.5 “Setting RBW/VBW”
[8]	Displays marker values. Spectrum Analyzer Function Operation ☞ 4.1 “Setting Marker”
[9]	Displays the reference level. Spectrum Analyzer Function Operation ☞ 2.4.1 “Setting reference level”
[10]	Displays the number of trace points Spectrum Analyzer Function Operation ☞ 3.3 “Setting Time/Sweep”

6. Frequency settings must be changed to display the input signal to the waveform display screen. Press **F1** (Frequency).
7. Press **F1** (Center Frequency) and then enter the desired frequency using the numeric keypad. The center frequency setup window is displayed.

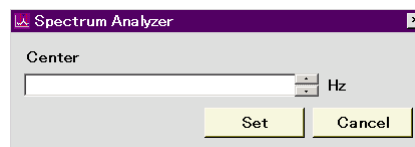

Figure 4.2.1-3 Center frequency setup window

8. Enter the center frequency then select the unit, from GHz, MHz, kHz, and Hz.
Example: To set 1 GHz for the center frequency, press **1** and then **F1** (GHz).
9. Return to the main screen of the spectrum analyzer to change frequency span. Press **Menu**.
10. Press **F2** (Span). Enter the desired frequency bandwidth using the numeric keypad.
11. Enter the frequency bandwidth then select the unit of the value.

The waveform of the input signal is now displayed on the screen (see Figure 4.2.1-4).

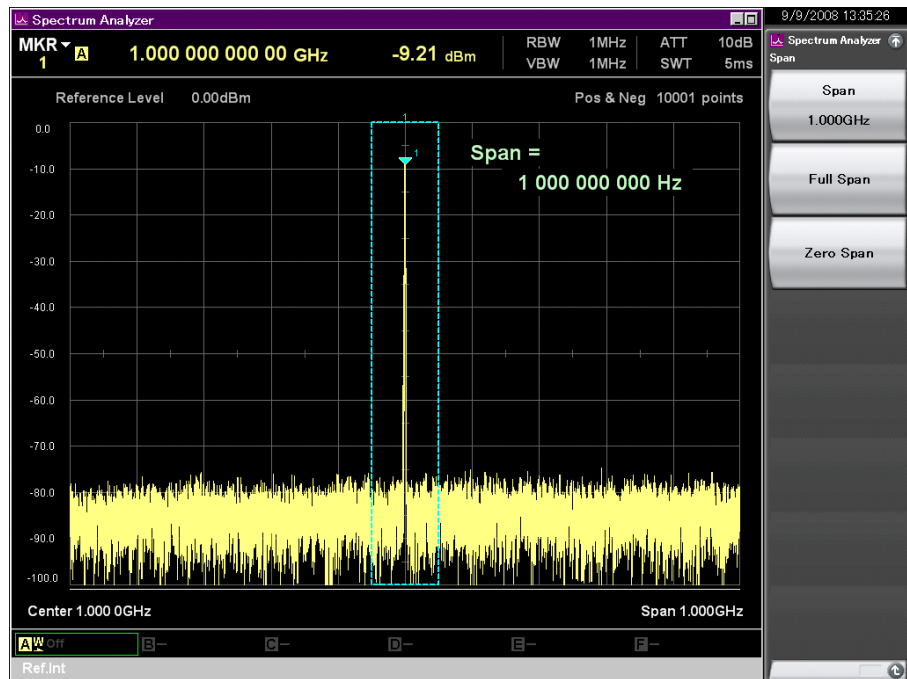

Figure 4.2.1-4 Waveform display using Spectrum Analyzer

Refer to the “MS2830A Signal Analyzer Operation Manual (Spectrum Analyzer Function Operation)” for how to use the Spectrum Analyzer.

Chapter 5 System

The MS2830A uses Microsoft Windows Embedded Standard 2009 (hereinafter, referred to as “Windows”) as the operating system. Settings for Windows and the system can be operated by connecting a mouse and a keyboard.

This section describes how to perform operations on Windows installed to the MS2830A and general notes.

5.1	Setting Windows	5-2
5.1.1	Displaying Windows Desktop	5-3
5.1.2	Setting Control Panel.....	5-4
5.1.3	Using external display	5-8
5.1.4	General notes	5-9
5.2	Storage Device Configuration.....	5-10
5.3	System Recovery Functions	5-11
5.3.1	Phoenix Recover Pro.....	5-12
5.3.2	Paragon Drive Backup.....	5-13

5.1 Setting Windows

The MS2830A is set to default settings at factory shipment so as to perform optimal measurements. Changing the Windows settings is outside the scope of operation warranty. In addition, performance may drop or functions may not operate correctly when Windows settings are changed. Carefully read the general notes of this section when changes to Windows settings are required.

When the system fails to operate correctly due to Windows operation, execute system recovery functions to restore the MS2830A to its status at factory shipment. See 5.3 “System Recovery Functions” for details.

 **WARNING**

MS2830A operations are not guaranteed when Windows settings are changed from their default shipment status, or when a program not guaranteed by Anritsu Corporation is installed.

Windows Embedded prohibits the installation of applications by user.

 **WARNING**

Performing system recovery will cause software installation (including updates) after factory shipment of the MS2830A and application settings to be lost. In addition, data (measurements, parameters, etc.) recorded by the customer may be deleted depending on the method to perform system recovery.

5.1.1 Displaying Windows Desktop

Connect a mouse and a keyboard to operate Windows. Use the USB mouse included as standard equipment and a compatible keyboard (USB).

The following are methods to display the Windows Desktop. To display applications of the MS2830A again, press  or select an application in the Windows Taskbar.

Mouse

Click the “Minimize” button located in the upper right corner of the application window of the MS2830A. Minimizing all applications displays the Desktop.

Keyboard

Pressing the [Windows] key + [D] key minimizes all windows and displays the Windows Desktop.

5.1.2 Setting Control Panel

Various Windows settings can be configured using the Control Panel. The following describes general notes on each setting. Although each setting can be set without using the Control Panel, use within the scope of the following restrictions.

Avoid changing settings listed in Table 5.1.2-1.

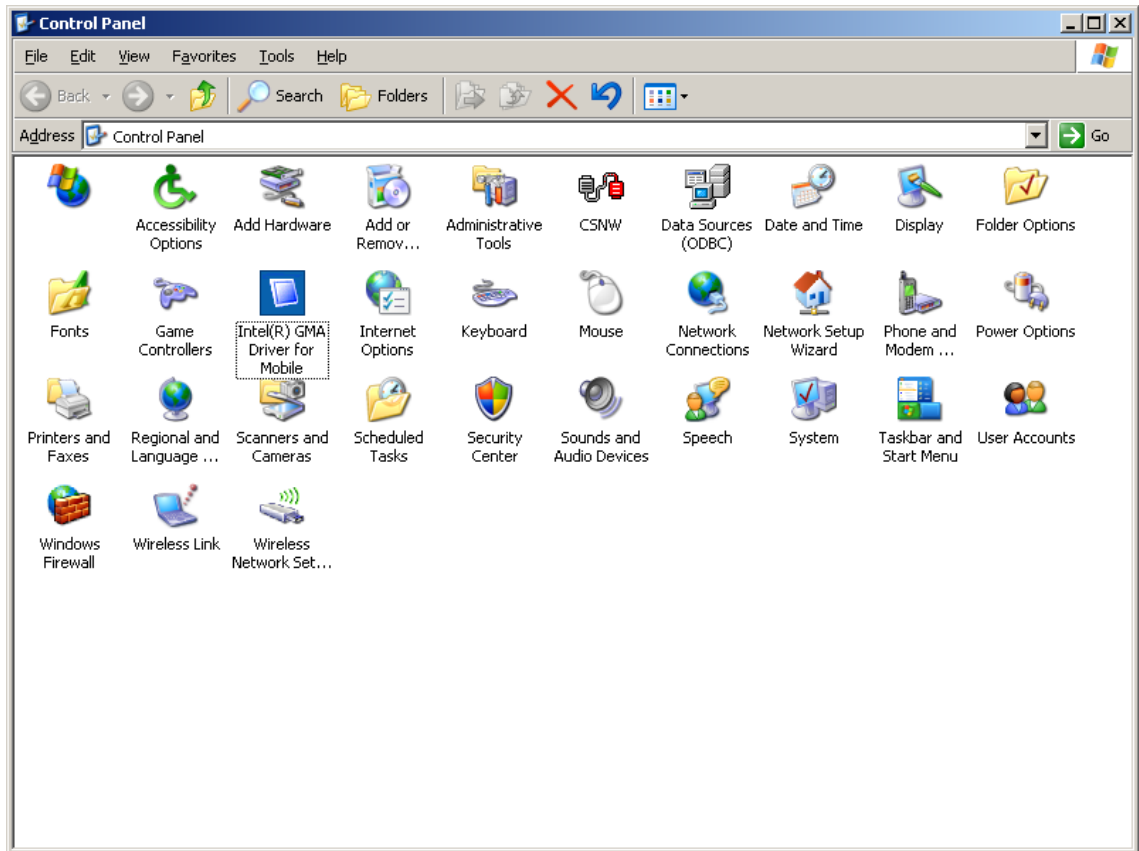

Figure 5.1.2-1 Control Panel

Table 5.1.2-1 Description of Control Panel







Setting Type	Description
	<p><u>Add Hardware</u></p> <ul style="list-style-type: none"> Do not delete devices already installed, or update or remove drivers. The MS2830A may not operate normally due to conflicts with device drivers when new hardware is added.
	<p><u>Add or Remove Programs</u></p> <ul style="list-style-type: none"> Do not update or remove programs installed at factory shipment. MS2830A operations are not guaranteed when programs not guaranteed by Anritsu Corporation are installed.
	<p><u>Administrative Tools</u></p> <ul style="list-style-type: none"> Do not change settings.
	<p><u>Automatic Update</u></p> <ul style="list-style-type: none"> Not available
	<p><u>Date & Time</u></p> <ul style="list-style-type: none"> You can change the date, time and time zone. Internet Time is set to Off at factory shipment. Operations may be affected; therefore, do not change this setting.
	<p><u>Display</u> <u>Intel® GMA Driver for Mobile</u></p> <ul style="list-style-type: none"> This setting must be changed when connecting an external monitor to the VGA connector of the MS2830A for use. See 5.1.3 “Using external display” for details. Changing the screen resolution, refresh rate or monitor power management, or enabling the screen saver may cause operations to be performed abnormally.
	<p><u>Font</u></p> <ul style="list-style-type: none"> Fonts required for applications of the MS2830A are installed at factory shipment; therefore, do not delete these fonts.

Table 5.1.2-1 Description of Control Panel (Cont'd)









Setting Type	Description
	<p><u>Network Connections</u></p> <ul style="list-style-type: none"> • TCP/IP settings may change when the MS2830A is remote-controlled via the Ethernet. Refer to “MS2690A/MS2691A/MS2692A and MS2830A Signal Analyzer Operation Manual (Mainframe Remote Control)” for details. • The IP address is set to use DHCP at factory shipment. Ensure that the network administrator settings are appropriate when connecting the MS2830A to a network.
	<p><u>Power Options</u></p> <ul style="list-style-type: none"> • The settings for the Auto Power Off function (Turn off Monitor) of the display can be changed. • The Power Off function of the hard disk (Turn off Hard Disks) is disabled (Never). Do not change this setting. • Do not change power option settings other than those described above. The MS2830A will not operate normally after recovering from hibernation.
	<p><u>Printer and Faxes</u></p> <ul style="list-style-type: none"> • Printers and fax machines can be set. However, operations are not guaranteed in the event print drivers or relevant applications affect the MS2830A.
	<p><u>Regional and Language</u></p> <ul style="list-style-type: none"> • Do not change this setting. Applications may not operate normally.
	<p><u>Security Center</u></p> <ul style="list-style-type: none"> • Firewall settings are set to Off at factory shipment. When settings are set to On, a dialog for checking whether the Windows Firewall blocks applications of the MS2830A when the applications are started the next time is displayed. Select “Unblock” at this time. • Antivirus software is not installed at factory shipment. We strongly recommend installing antivirus software when connecting the MS2830A to a network. However, the remote control function using the Ethernet of the MS2830A may not operate in the event functions for blocking external communications are operating. • Warnings from the Security Center are set to not be displayed at factory shipment.

Table 5.1.2-1 Description of Control Panel (Cont'd)

Setting Type	Description
	<p><u>System</u></p> <ul style="list-style-type: none"> The Computer Name can be changed. The name is set as “SA” + “Serial Number” at factory shipment. Do not change Hardware or Advanced settings.
	<p><u>Taskbar and Start Menu</u></p> <ul style="list-style-type: none"> Do not change settings.
	<p><u>User Account</u></p> <ul style="list-style-type: none"> Automatic login is set under the following settings at factory shipment. Do not change the User Account settings shown below. <ul style="list-style-type: none"> Account Name “ANRITSU” Password None Account Type Computer Administrator New user accounts can be created. Specify “Computer Administrator” for the account type of the user account to be created. Applications will not startup normally with user accounts created using Limited (Power User).
	<p><u>Windows Firewall</u></p> <ul style="list-style-type: none"> Firewall settings are set to Off at factory shipment. When settings are set to On, a dialog for checking whether the Windows Firewall blocks applications of the MS2830A when applications are started the next time is displayed. Be sure to select “Unblock” at this time.

5.1.3 Using external display

An external display can be connected to the VGA connector on the rear side of the MS2830A, to display screens of the MS2830A and show multiple displays. The following describes the operation procedure for this function.

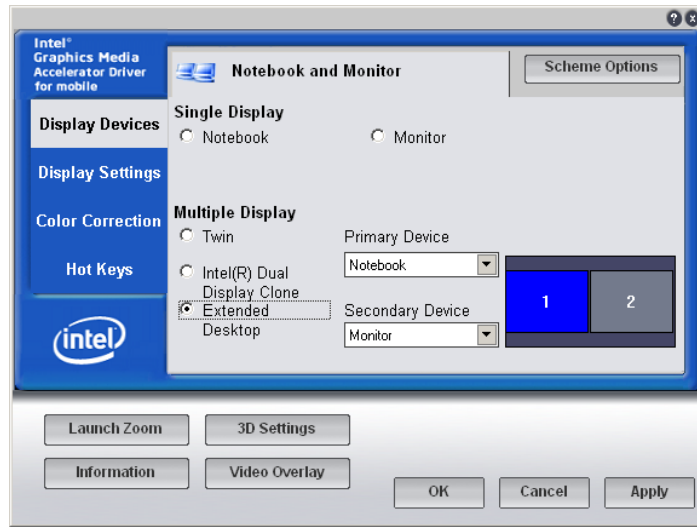

<Procedure>

1. Connect the display to the VGA connector on the rear side of the MS2830A.
2. Display the Intel® GMA Driver Settings screen using any of the following methods.
 - Execute “Intel® GMA Driver for Mobile” from the Windows Control Panel.
 - Press [Ctrl] + [Alt] + [F12] on the keyboard.
3. Change the Display Devices settings as shown below:

When not using an external display

- Single Display Notebook

When using only an external display

- Single Display Monitor

When displaying the MS2830A display to an external display

- Multiple Display Twin or Intel® Dual Display Clone
- Primary Device Notebook (MS2830A display)
- Secondary Device Monitor

When displaying with the MS2830A and external display connected

- Multiple Display Extended Desktop
- Primary Device Notebook (MS2830A display)
- Secondary Device Monitor



CAUTION

Turning the MS2830A power On when an external display is not connected to the VGA connector initializes to mainframe display only. When continuously using an external display, it is recommended to keep the external monitor connected for use.



CAUTION

Do not change the resolution, refresh rate or power management settings of the mainframe monitor.

5.1.4 General notes

Besides the general notes on the previous section, note the following operations.

- Operation of the MS2830A is guaranteed at factory shipment status. Operation is not guaranteed when programs, including Windows Update, are added or updated.
- When third party software is installed and/or executed, this may affect MS2830A operations.
- Note that the MS2830A may not operate normally when registries are changed.

5.2 Storage Device Configuration

The MS2830A has a built-in hard disk for storing the operating system, application software, user data, and the like.

The hard disk of the MS2830A consists of the following partitions.

Volume C: System Disk

Windows, application software and files required for operation of the MS2830A are stored. The MS2830A may not operate normally when data required for operating the MS2830A are changed or deleted. Do not operate data of this volume at normal use.

Volume D: Hard Disk

This volume is used mainly for inputting files to and as the output destination for the application software of the MS2830A. Adding data to this volume or deleting data on it will not affect MS2830A operations.

A USB memory, used for installing application software and inputting or outputting data, is included as standard equipment with the MS2830A. The USB memory is recognized as Drive E at factory shipment.

Note the following items when operating MS2830A:

- Do not change the partition configuration. Doing so may affect system operation.
- Do not format the hard disk of the MS2830A. Besides the above, data for system recovery is stored within this hard disk. Recovery may become inoperable when the hard disk is formatted.
- The volumes and folders described above are not set to be shared at factory shipment. Although sharing is an effective means for transferring data to and from an external PC, be mindful of security when connecting to a network.

5.3 System Recovery Functions

The MS2830A has system recovery functions to restore data on the hard disk to the factory shipment status. These functions can be used in the event of system instability.

The MS2830A comes with factory-installed recovery software, Phoenix Recover Pro or Paragon Drive Backup. To confirm the installed recovery software, start the MS2830A, and press the **F4** key on the BIOS screen to start the recovery software.

<Procedure>

1. Disconnect the MS2830A from the network if connected.
2. Connect the keyboard and mouse to the mainframe, and then turn the MS2830A power On. The BIOS screen will appear in a few seconds after (The message “Press F2 for System Utilities” appears at the bottom part of the screen).
3. Press the **F4** key (not  on the front panel of the mainframe) while the screen in Step 2 is displayed.
4. Only when the screen displays the message “Press F4 to start recovery from Backup Capsule”, press the **F4** key again.
5. According to the software instructions on the screen, perform a system recovery.

Phoenix Always

Refer to Section 5.3.1 “Phoenix Recover Pro”.

Paragon Drive Backup

Refer to Section 5.3.2 “Paragon Drive Backup”.

CAUTION

To execute these functions, understand the following items for their use.

- All applications and updates added after factory shipment will be lost. Additionally, all data recorded to Volume C will be restored to the factory shipment status. Backup important data before executing these functions.
- The user data area of Volume D can be restored to the factory shipment status depending on the function to be selected. So as not to lose important user data due to incorrect operations, it is recommended to backup data in Volume D before executing these functions.

- **Data deleted by these functions cannot be restored.**
 - **When the Paragon Drive Backup software is installed, the backup data is saved to an unknown partition on the Disk 0. If the unknown partition is accidentally deleted, the backup data required for system recovery is deleted as well.**
-

5.3.1 Phoenix Recover Pro

This subsection describes how to perform a system recovery with factory-installed recovery software “Phoenix Recover Pro”.

Restore System drive (partition) only

This function restores only Volume C, in which Windows, application software, and files required for operations of the MS2830A are stored, to the factory shipment status.

Restore entire hard disk

This function restores Volume C and Volume D to the factory shipment status. Although Volume D is mainly used as a storage area for user data, all data on Volume D will be erased.

<Procedure>

1. After the screen displaying “Phoenix Always” appears, the following alternatives are displayed on the screen:

Restore System drive (partition) only

Recovers only Volume C.

Restore entire hard disk

Recovers Volumes C and D.

Select one of the two alternatives, and then click [NEXT]. To cancel, press and hold the [Power] button of the mainframe to power off.

2. After clicking [NEXT], the confirmation screen appears. Click [OK] to start a system recovery. Although the required time for recovery varies depending on the conditions, it normally takes between 10 and 30 minutes. The progress of recovery is shown during recovery. Although the progress indicator may close during recovery, this is a normal operation.

The MS2830A will restart automatically then normal startup will be executed.

5.3.2 Paragon Drive Backup

This subsection describes how to perform a system recovery with factory-installed recovery software “Paragon Drive Backup”.

Type: Partition

This function restores only Volume C, in which Windows, application software, and files required for operations of the MS2830A are stored, to the factory shipment status.

Type: Disk

This function restores Volume C and Volume D to the factory shipment status. Although Volume D is mainly used as a storage area for user data, all data on Volume D will be erased.

<Procedure>

1. After the screen displaying “Drive Backup” appears, the following alternatives are displayed on the screen:

Normal Mode

Safe Mode

Select [Normal Mode] with the arrow keys, and then press the **Enter** key.

2. When the menu screen appears in about a minute, double-click [Simple Restore Wizard].
3. The [Paragon Simple Restore Wizard] appears, so click [Next].
4. The following alternatives are displayed on the screen:

Type: Partition

Recovers only Volume C.

Type: Disk

Recovers Volumes C and D.

Double-click either of them, and then click [NEXT].

5. When the confirmation screen appears, click [Yes] to start a system recovery. Then, the [Progress information] dialog box appears, and the recovery process starts.

Do not click [Cancel] when a system recovery is in progress.

Although the required time for recovery varies depending on the conditions, it normally takes between 10 and 30 minutes. The progress of recovery is shown during recovery. Although the progress indicator may close during recovery, this is a normal operation.

6. Upon completion of the recovery process, click [Close]. ([Close] appears after the recovery process is completed.)
7. When the completion screen appears, click [Finish] to return to the menu screen described in Step 5. Click [Reboot the computer] to reboot the MS2830A, or click [Power off] to turn the power Off.

Chapter 6 Performance Test

This chapter describes measurement devices, setup methods, and performance test procedures required for performing performance tests as preventive maintenance of the MS2830A.

6.1	Overview of Performance Test	6-2
6.1.1	Performance test	6-2
6.1.2	Performance test items and instruments used	6-3
6.2	Performance Test Items	6-5
6.2.1	Reference oscillator frequency stability	6-6
6.2.2	Display frequency accuracy	6-8
6.2.3	Frequency span display accuracy	6-10
6.2.4	Single sideband noise level	6-12
6.2.5	RF frequency characteristics	6-15
6.2.6	Display average noise level	6-20
6.2.7	Second harmonic wave distortion	6-26

6.1 Overview of Performance Test

6.1.1 Performance test

Performance tests are performed as part of preventive maintenance in order to prevent the performance of the MS2830A from being degraded before it occurs.

Use performance tests when required for acceptance inspection, routine inspection and performance verification after repairs. Perform items deemed critical at regular intervals as preventive maintenance. Perform the following performance tests for acceptance inspection, routine inspection and performance verification after repairs of the MS2830A.

- Reference oscillator frequency stability
- Display frequency accuracy
- Frequency span display accuracy
- Single sideband noise level
- RF frequency characteristics
- Display average noise level
- Second harmonic wave distortion

Perform items deemed critical at regular intervals as preventive maintenance. A recommended cycle for routine tests of once or twice a year is desirable.

If items that do not meet the required level are detected during performance testing, contact an Anritsu Service and Sales office. Contact information can be found on the last page of the printed version of this manual, and is available in a separate file on the CD version.

6.1.2 Performance test items and instruments used

Table 6.1.2-1 lists measuring instruments used or performance tests.

Table 6.1.2-1 List of measuring instruments for performance test

Test Items	Required Performance	Name of Recommended Device (Model Name)
Reference oscillator frequency stability	<ul style="list-style-type: none"> • Aging rate: $\leq 3 \times 10^{-12}$/day or less • 10 MHz measurability • Number of digits displayed: 10 or more 	Frequency standard device (HP5071A Option 001)
		Frequency counter (MF2412C)
Display frequency accuracy	<ul style="list-style-type: none"> • Frequency range: 500 MHz to 31 GHz 1 Hz resolution available • Output level range: -20 to 0 dBm 0.1 dB resolution available 	Signal generator (MG3691C/92C/94C) With Option 004 or 005
Frequency span display accuracy	<ul style="list-style-type: none"> • Frequency range: 300 MHz to 40 GHz 1 Hz resolution available • Output level range: -20 to 0 dBm 0.1 dB resolution available 	Signal generator (MG3691C/92C/94C) With Option 004 or 005
Single sideband noise level	<ul style="list-style-type: none"> • Frequency range: 1 GHz, 1 MHz offset 1 Hz resolution available • Output level range: -10 to 10 dBm 0.1 dB resolution available • SSB phase noise: -130 dBc/Hz or less (at 100 kHz offset) • SSB phase noise: -150 dBc/Hz or less (at 1 MHz offset) • External reference input: (10 MHz) available 	Signal generator (HP8665B)

Table 6.1.2-1 List of measuring instruments for performance test (Cont'd)

Test Items	Required Performance	Name of Recommended Device (Model Name)
RF frequency characteristics	<ul style="list-style-type: none"> • Frequency range: 10 MHz to 40 GHz 1 Hz resolution available • Output level range: -20 to 0 dBm 0.1 dB resolution available 	Signal generator (MG3700A) Less than 6 GHz
		Signal generator (MG3691C/92C/94C) 6 GHz or more
	<ul style="list-style-type: none"> • Frequency range: 10 MHz to 40 GHz • Measurement power range -67 to +20 dBm • Mainframe accuracy ± 0.02 dB 	Power meter (ML2488B)
Display average noise level	<ul style="list-style-type: none"> • Frequency range: DC to 43 GHz • VSWR: 1.2 or less • 50 Ω 	MS2830A-040/041/043/044 Standard terminator (28N50-2)
		MS2830A-045 Standard terminator (28K50)
Second harmonic wave distortion	<ul style="list-style-type: none"> • Frequency range: 50 MHz to 6.75 GHz • External reference input: (10 MHz) available • Second harmonic wave: -30 dBc or less • At 2\times frequency of SG output: Loss < 40 dB (LPF) 	Signal generator (MG3700A) up to 6 GHz
		Signal generator (MG3692C) from 6 GHz
		Low pass filter SLP-50+ : fc=55 MHz VLF-400 (+) : fc=560 MHz VLF-2250 (+) : fc=2575 MHz VLF-3000+ : fc=3600 MHz VLF-6000(+) : fc=6800 MHz VLF-6700+ : fc=7600 MHz

6.2 Performance Test Items

Warm up the subject testing device and measuring instruments for at least 30 minutes except where directed, in order to stabilize them sufficiently before running performance tests. Demonstrating maximum measurement accuracy requires, in addition to the above, conducting performance tests under ambient temperatures, little AC power supply voltage fluctuations, as well as the absence of noise, vibrations, dust, humidity or other problems.

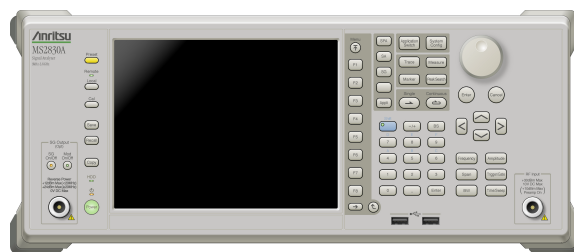

Figure 6.2-1 Performance test

6.2.1 Reference oscillator frequency stability

This tests the frequency stability of the 10 MHz reference oscillator of the MS2830A.

The frequency stability is tested by measuring at 23°C the frequency changes from the elapse of 24 hours after power application, and by measuring the frequency changes at ambient temperatures of 5°C and 45°C.

However, this is applied for this item when Option 001/101 is not installed.

(1) Test target standards

■ Reference oscillator

With MS2830A-040/-041/-043 installed,

- Frequency: 10 MHz
- Aging Rate $\pm 1 \times 10^{-6}$ /year
- Temperature characteristics $\pm 2.5 \times 10^{-6}$
5°C to 45°C (reference temperature = 23°C)

With MS2830A-044/-045 installed,

- Frequency: 10 MHz
- Aging Rate $\pm 1 \times 10^{-7}$ /year
- Temperature characteristics $\pm 2 \times 10^{-8}$ 5°C to 45°C
(reference temperature = 23°C)

(2) Measuring instrument for tests

- Frequency counter: MF2412C
- Frequency standard device: Devices with stability of $\pm 3 \times 10^{-12}$ /day or less

(3) Setup

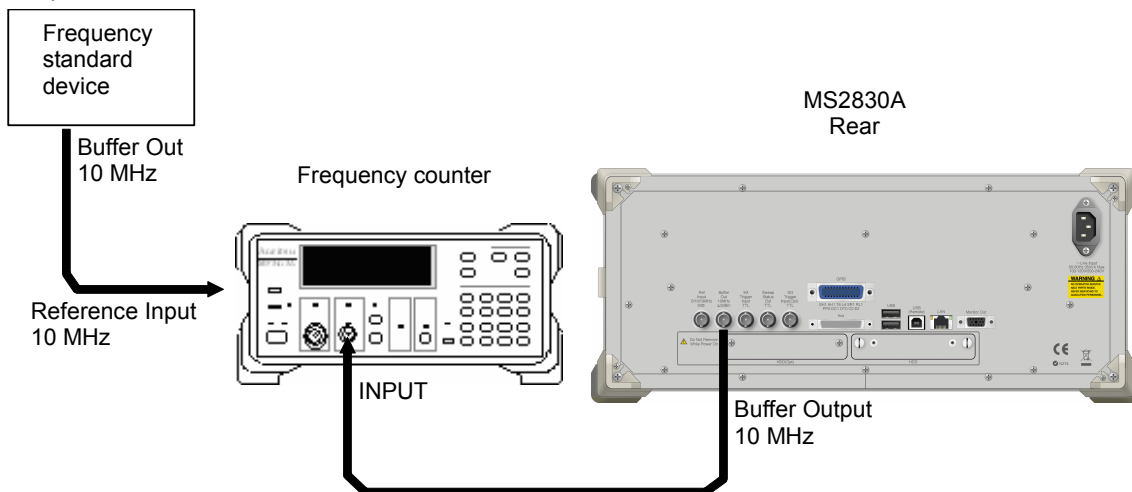

Figure 6.2.1-1 Reference oscillator frequency stability test

(4) Notes on test

Perform tests at temperature stability in (5) in locations where ambient temperature changes are at $\pm 2^{\circ}\text{C}$, and there are no vibrations.

(5) Test procedure

(a) Temperature stability

1. Set only the MS2830A to a thermostatic bath at the connection in (3) then set to the temperature within the bath to 23°C .
2. Turn On the power switch on the front panel of the MS2830A then wait until the internal temperature of the MS2830A stabilizes (approx. 1.5 hours after the temperature in the thermostatic bath stabilizes).
3. When the internal temperature is stabilized, measure the frequency with Frequency counter (up to the 0.1 MHz digit).
4. Set the temperature in the bath to 45°C .
5. When the temperature in the bath and the internal temperature of the MS2830A are stabilized, measure the frequency with Frequency counter.
6. Calculate the stability using the following equation.

$$\text{Frequency temperature stability} = \frac{(\text{Counter reading at } 45^{\circ}\text{C}) - (\text{Counter reading at } 23^{\circ}\text{C})}{(\text{Counter reading at } 23^{\circ}\text{C})}$$

7. Set the temperature in the bath to 5°C then perform Steps 5 and 6.

6.2.2 Display frequency accuracy

The known frequency which is the reference for the display frequency, is added to the MS2830A as shown in (3) then the center frequency and frequency span are set from the front panel. The difference between the read value of the marker display frequency (bold arrow in figure below) of the spectrum peak point and the setting value of the center frequency (same value as known reference frequency) is measured at this time.

The Swept Frequency Synthesizer uses the signal source phase-locked using the same accuracy as the 10 MHz reference oscillator of the MS2830A.

(1) Test target standards

■ MS2830A

- Display frequency accuracy: $\pm [\text{Display frequency} \times \text{Reference frequency accuracy} + \text{Span frequency} \times \text{Span accuracy} + \text{RBW} \times 0.05 + 2 \times N + \text{Span Frequency} / (\text{No. of trace points} - 1)] \text{ Hz}$
 N indicates the mixing order (Refer to Table 1.3.1-1).

(2) Measuring instrument for tests

- Signal generator (MG3691C/92C/94C)

(3) Setup

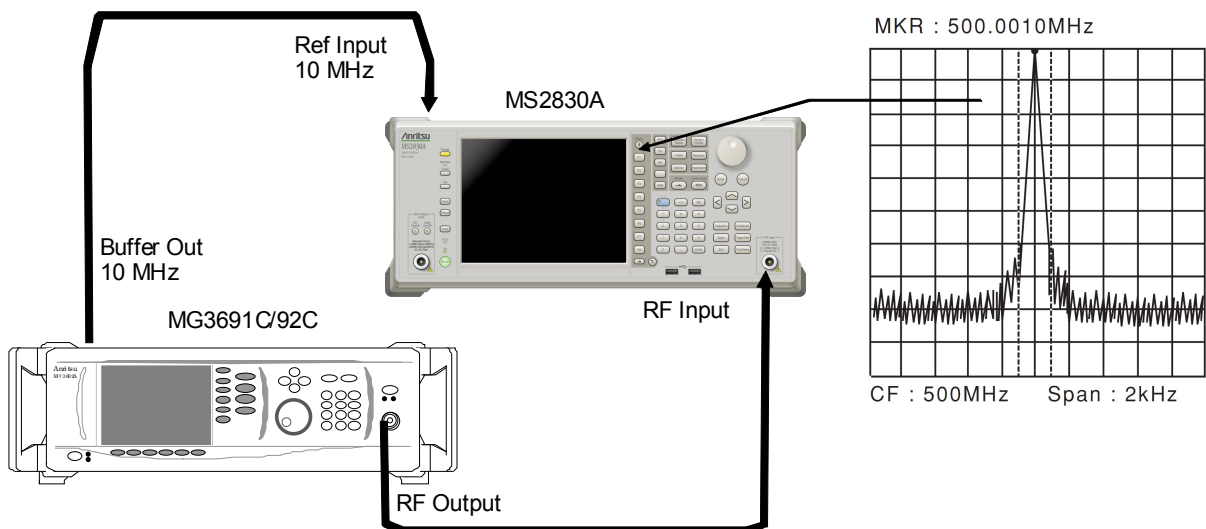





Figure 6.2.2-1 Display frequency accuracy test

(4) Notes on test

Set the output level of the MG3691C/92C/94C to -20 to -10 dBm

(5) Test procedure

1. Press  of the MS2830A, and then select the Spectrum Analyzer.
2. Press  of the MS2830A.
3. Press  (Preset) to perform Preset.
4. Press  of the MS2830A to display the Frequency function menu.
5. Set the output frequency of the MG3691C/92C/94C to the center frequency (500 MHz) shown in the Display Frequency Accuracy table of Appendix A.
6. Set the center frequency shown in the Display Frequency Accuracy table of Appendix A to the MS2830A.
7. Set the frequency span (10 kHz) and the resolution bandwidth (300 Hz) corresponding to the center frequency (500 MHz) shown in the Display Frequency Accuracy table of Appendix A to the MS2830A.
8. Read the marker frequency value (MKR value) shown on the screen, then check whether this value is within the range of the maximum value and minimum value in the specified range shown in the Display Frequency Accuracy table of Appendix A.
9. Repeat Steps 5 to 8 for the center frequency and frequency span according to the center frequency and frequency span combination shown in the Display Frequency Accuracy table of Appendix A.

6.2.3 Frequency span display accuracy

Set to the signal generator the frequencies of the first div and ninth div from the left edge of the screen as shown in (3), and read their frequency difference to obtain the span accuracy.

(1) Test target standards

- MS2830A
 - Frequency span accuracy: $\pm 0.2\%$

(2) Measuring instrument for tests

- Signal generator (MG3691C/92C/94C)

(3) Setup

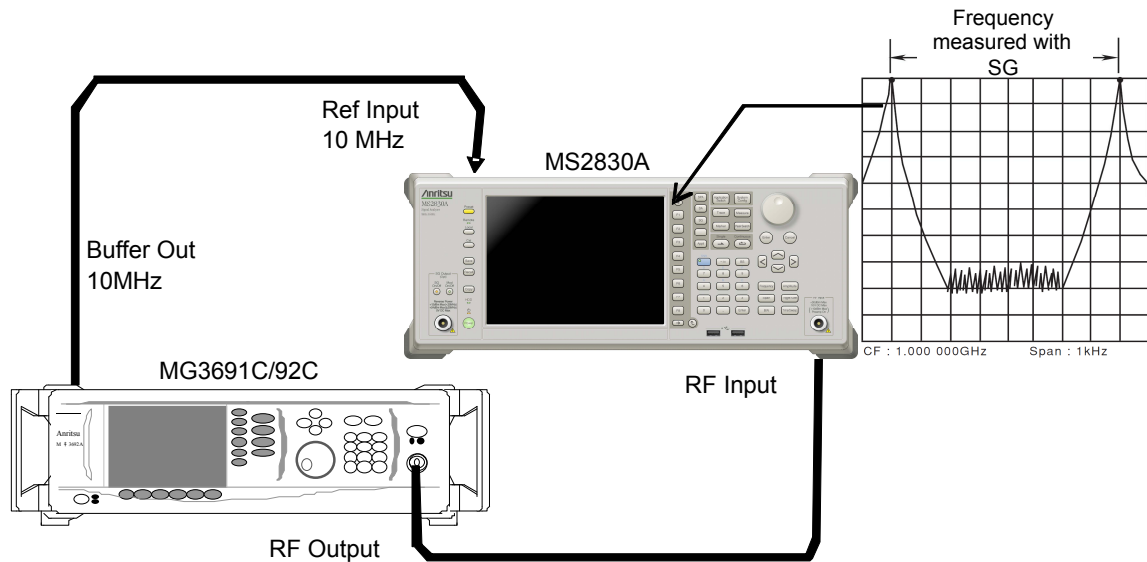





Figure 6.2.3-1 Frequency span display accuracy test

(4) Notes on test

Although the output level of the MG3691C/92C/94C is not specified, set normally to -10 to 0 dBm.

(5) Test procedure

1. Press  of the MS2830A, and then select the Spectrum Analyzer.
2. Press  of the MS2830A.
3. Press  (Preset) to perform Preset.
4. Connect the output of the MG3692A to the RF input of the MS2830A.
5. Set the frequency span (10 kHz) and center frequency (3 GHz) of the MS2830A from the Frequency Span Display Accuracy table of Appendix A.
6. Set the output frequency of the MG3691C/92C/94C to the frequency (1799.996 MHz) for f_1 shown in the Frequency Span Display Accuracy table of Appendix A.
7. Measure the spectrum waveform peak frequency by using the marker function of the MS2830A. This frequency is set to f_1' .
8. Set to the frequency of output frequency f_2 of the MG3691C/92C/94C (1800.004 MHz), and then measure the spectrum waveform peak frequency by using the marker function. This frequency is set to f_2' .
9. Calculate $(f_2' - f_1')/0.8/\text{SPAN} \times 100 - 100$ [%] then check whether it satisfies the specified range (minimum value to maximum value) shown in the Frequency Span Display Accuracy table of Appendix A.
10. Repeat Steps 5 to 9 for each frequency span of the center frequency shown in the Frequency Span Display Accuracy table of Appendix A.

6.2.4 Single sideband noise level

Set the resolution bandwidth to a specific value then input a signal with a single sideband noise level far smaller than the subject test device. Test how far the dB drops from the peak point for a noise level which is distanced by a specific frequency from the spectrum waveform peak point at this time.

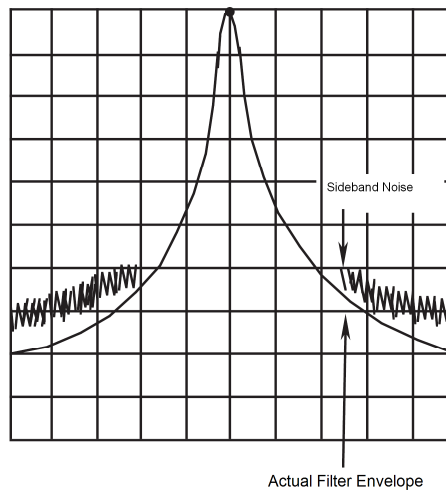

Figure 6.2.4-1 Single sideband noise level

(1) Test target standards

- Single sideband noise: At 18 to 28°C, 500 MHz
 ≤ -115 dBc/Hz (Frequency 500 MHz, 100 kHz Offset)
 ≤ -133 dBc/Hz (Frequency 500 MHz, 1 MHz Offset)

(2) Measuring instrument for tests

- Signal generator (HP8665B)

(3) Setup

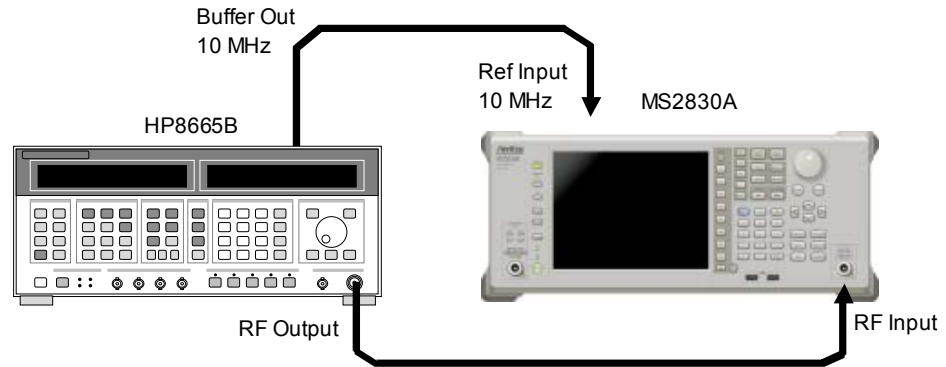





Figure 6.2.4-2 Signal sideband noise level

(4) Notes on test

Perform the test at an ambient temperature of 18 to 28°C and after warming up for at least 30 minutes.

(5) Test procedure

1. Start the application Spectrum Analyzer of the MS2830A.
2. Press .
3. Press  (Preset).
4. Press  and then  (SIGANA All).
5. Set 500 MHz, 0 dBm for the HP8665B.
6. Set as follows for the MS2830A:

Reference level	0 dBm
Attenuator	0 dB
Span frequency	0 Hz
VBW mode	Power
Det mode	Sample
RBW	100 Hz
VBW	1 Hz
Sweep time	1 s
Trace points	1001
7. Set the center frequency of the MS2830A to 500 MHz.

8. Measure the following parameters for the burst average measurement function. Adjust the output level of the MP8665B so that the average measurement value becomes 0 dBm \pm 0.06 dB, and then measure level [p0].
Start time 0.1 s
Stop time 0.9 s
9. For the MS2830A, set the center frequency (500.1 MHz) corresponding to the offset frequency (100 kHz) shown in the Single Sideband Noise Level table of Appendix A.
Also, set RBW to 10 kHz according to this table.
10. Measure level [p1] by using the burst average measurement function.
11. Calculate the single sideband noise using the measurement value.
Single sideband noise = $p1 - p0 - 10 \log 10000$ [dBc/Hz]
12. In the same way as Step 9, measure level [p2] at the center frequency (501 MHz).
13. Calculate the single sideband noise using the measurement value.
Single sideband noise = $p2 - p0 - 10 \log 30000$ [dBc/Hz]

6.2.5 RF frequency characteristics

Even if multiple signals with different frequencies and the same amplitude are input to a spectrum analyzer, the amplitude of each spectrum must be displayed equally on the screen. This section describes how to obtain the level deviation of the frequency for each band by inputting calibrated signals from an external device.

(1) Test target standards

- RF frequency characteristics

After CAL execution, 18° to 28°C, input attenuator = 10 dB, Frequency Band Mode: Normal

■ MS2830A

With MS2830A-040/041/043 installed,

Without MS2830A-008/108 or with Preamplicifier turned off:

±1.0 dB

(9 kHz ≤ frequency < 300 kHz)

±0.35 dB

(300 kHz ≤ frequency < 4 GHz, Frequency Band Mode: Normal)

(300 kHz ≤ frequency < 3.5 GHz, Frequency Band Mode: Spurious)

±1.50 dB

(4 GHz ≤ frequency ≤ 6 GHz, Frequency Band Mode: Normal)

(3.5 GHz ≤ frequency ≤ 6 GHz, Frequency Band Mode: Spurious)

±1.50 dB

(6 GHz < frequency)

With MS2830A-008/108 and Preamplicifier turned on:

±0.65 dB

(300 kHz ≤ frequency < 4 GHz, Frequency Band Mode: Normal)

(300 kHz ≤ frequency < 3.5 GHz, Frequency Band Mode: Spurious)

±1.8 dB

(4 GHz ≤ frequency ≤ 6 GHz, Frequency Band Mode: Normal)

(3.5 GHz ≤ frequency ≤ 6 GHz, Frequency Band Mode: Spurious)

With MS2830A-044/045 installed,

Without MS2830A-008/108/068/168, or with Preamplicifier turned off,

Without MS2830A-067/167 or with Microwave Preselector Bypass turned off and after Preselector Auto Tune is done:

±1.0 dB

(9 kHz ≤ Frequency < 300 kHz)

±0.35 dB

(300 kHz ≤ Frequency < 4 GHz, Frequency Band Mode: Normal)

(300 kHz ≤ Frequency < 3.5 GHz, Frequency Band Mode: Spurious)

±1.50 dB

(4 GHz ≤ Frequency ≤ 6 GHz, Frequency Band Mode: Normal)

(3.5 GHz ≤ Frequency ≤ 6 GHz, Frequency Band Mode: Spurious)

±1.50 dB

(6 GHz < Frequency ≤ 13.8 GHz)
±2.50 dB
(13.8 GHz < Frequency ≤ 26.5 GHz)
±2.50 dB
(26.5 GHz < Frequency ≤ 40 GHz)

With MS2830A-008/108 and Preamplifier turned on:

±0.65 dB
(300 kHz ≤ Frequency < 4 GHz, Frequency Band Mode: Normal)
(300 kHz ≤ Frequency < 3.5 GHz, Frequency Band Mode: Spurious)
±1.8 dB
(4 GHz ≤ Frequency ≤ 6 GHz, Frequency Band Mode: Normal)
(3.5 GHz ≤ Frequency ≤ 6 GHz, Frequency Band Mode: Spurious)

With MS2830A-068/168, with Preamplifier turned on,
Without MS2830A-067/167 or with Microwave Preselector Bypass turned off and after Preselector Auto Tune is done:

±0.65 dB
(300 kHz ≤ Frequency < 4 GHz, Frequency Band Mode: Normal)
(300 kHz ≤ Frequency < 3.5 GHz, Frequency Band Mode: Spurious)
±1.8 dB
(4 GHz ≤ Frequency ≤ 13.8 GHz, Frequency Band Mode: Normal)
(3.5 GHz ≤ Frequency ≤ 13.8 GHz, Frequency Band Mode: Spurious)
±2.50 dB
(13.8 GHz < Frequency ≤ 26.5 GHz)
±3.00 dB
(26.5 GHz < Frequency ≤ 40 GHz)

(2) Measuring instrument for tests

- Signal generator (MG3700A) [Less than 6 GHz]
- Signal generator (MG3691C/92C/94C) [6 GHz or more]
MG3691C is valid for MS2830A-041 and MG3692C is valid for MS2830A-043.
- Power meter (ML2488B)
- Power sensor (MA2444D)

(3) Setup

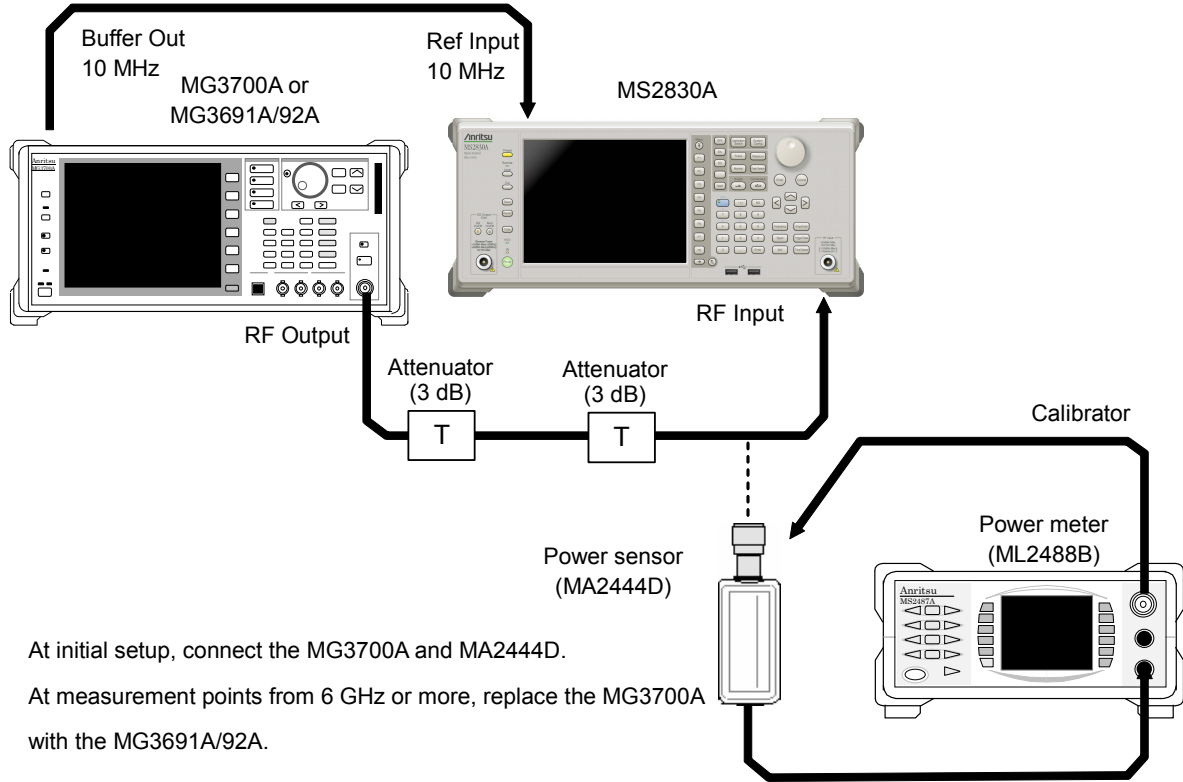

At initial setup, connect the MG3700A and MA2444D.

At measurement points from 6 GHz or more, replace the MG3700A with the MG3691A/92A.

Figure 6.2.5-1 RF frequency characteristics test

(4) Notes on test

Perform the test at an ambient temperature of 18 to 28°C and after warming up for at least 30 minutes.

Regarding the cable, attenuator, and conversion adapter, the applied parts below are recommended.





- Cable: J0912 Coaxial cord (for 40 GHz)
- Attenuator: 41KC-3 Fixed Attenuator, 3 dB
- Conversion adapter: J1398A N-SMA ADAPTOR



(5) Test procedure

(a) Calibrating the MG3700A (MG3691C/92C/94C) output level

1. Set the MG3700A (MG3691C/92C/94C) as follows:
OUTPUT FREQ 10 MHz
OUTPUT LEVEL -4 dBm
2. Connect the MG3700A (MG3691C/92C/94C) output to the power sensor of the power meter via the coaxial cable.
3. Check the power meter display.
4. Change the output frequency of the MG3700A (MG3691C/92C/94C) to the center frequency shown in the RF Frequency Characteristics table of Appendix A. Perform calibration by using the power meter so that the signal level at each frequency becomes $-10 \text{ dBm} \pm 0.06 \text{ dB}$, and then read the setting value on the MG3700A (MG3691C/92C/94C) and the indicated value (calibration value) on the power meter.

(b) Measuring RF frequency characteristics

1. Connect the MG3700A (MG3691C/92C/94C) RF output to the RF input of the MS2830A using the coaxial cable.
2. Start the application Spectrum Analyzer of the MS2830A.
3. Press  of the MS2830A.
4. Press  (Preset).
5. Press  and then  (SIGANA All).
6. Set as follows for the MS2830A:
Center Freq 10 MHz
Span 0 Hz
ATT 10 dB
Reference Level -10 dBm
RBW 100 Hz
Sweep Time 50 ms
Trace Point 1001
Det Mode RMS
7. Output the signal (calibration value) of the MG3700A (MG3691C/92C/94C) calibrated in Step (a) 4 to the MS2830A.
8. Using the burst average measurement function, set the following parameters and measure the level.
Start Time 5 ms
Stop Time 45 ms

9. Repeat the measurement, changing the frequency as shown in the RF Frequency Characteristics table of Appendix A.
10. Calculate the RF frequency characteristics, using the calibration value of the MG3700A (MG3691C/92C/94C) and the indicated value on the MS2830A.
RF frequency characteristics = Indicated value on MS2830A – calibration value (indicated value on power meter)
11. Set this instrument shown as below, only when Preamplifier option is installed:
In the same way as shown in (a) Calibrating the MG3700A (MG3691C/92C/94C) output level, perform calibration by using the power meter so that the signal level at each frequency becomes $-30 \text{ dBm} \pm 0.06 \text{ dB}$.
12. Press  to display the amplitude menu, and then press  (Pre-amp) to set the pre-amplitude settings to On.
Calculate RF frequency characteristic, according to steps 8 and 9.

Center Freq	50 MHz
Span	0 Hz
ATT	10 dB
Reference Level	-30 dBm
RBW	100 Hz
Sweep Time	50 ms
Trace Point	1001
Det Mode	RMS

6.2.6 Display average noise level

Internal noise evenly distributed in proportion to the resolution bandwidth across the entire measurement frequency band is referred to as the display average noise level.

(1) Test target standards

- Display average noise level
VBW = 1 Hz (Video Average), detection mode: Sample, input attenuator 0 dB, at 18 to 28°C, Frequency Band Mode: Normal.

■ MS2830A

With MS2830A-040/041/043 installed,

Without MS2830A-062/066/008/108 or with Preamplifier turned off:

- ≤ -134 dBm/Hz (100 kHz)
- ≤ -144 dBm/Hz (1 MHz)
- ≤ -153 dBm/Hz (30 MHz ≤ frequency < 1 GHz)
- ≤ -151 dBm/Hz (1 GHz ≤ frequency < 2.4 GHz)
- ≤ -149 dBm/Hz (2.4 GHz ≤ frequency ≤ 3.5 GHz)

MS2830A-041/043 installed,

- ≤ -146 dBm/Hz (3.5 GHz < frequency ≤ 6 GHz)

MS2830A-043 installed

- ≤ -142 dBm/Hz (6 GHz < frequency ≤ 13.5 GHz)

Without MS2830A-062/066, and with MS2830A-008/108, or with Preamplifier turned on:

- ≤ -156 dBm/Hz (1 MHz)
- ≤ -163 dBm/Hz (30 MHz ≤ frequency < 1 GHz)
- ≤ -162 dBm/Hz (1 GHz ≤ frequency < 2 GHz)
- ≤ -160 dBm/Hz (2 GHz ≤ frequency ≤ 3.5 GHz)

MS2830A-041/043 installed, Frequency Band Mode: Normal

- ≤ -157 dBm/Hz (3.5 GHz < frequency ≤ 4 GHz)

MS2830A-041/043 installed, Frequency Band Mode: Spurious

- ≤ -157 dBm/Hz (3.5 GHz < frequency ≤ 4 GHz)

MS2830A-041/043 installed

- ≤ -157 dBm/Hz (4 GHz < frequency ≤ 6 GHz)

With MS2830A-062/066 installed and without MS2830A-008/108 installed, or with Preamplifier turned off:

- ≤ -133 dBm/Hz (100 kHz)
- ≤ -143 dBm/Hz (1 kHz)
- ≤ -152 dBm/Hz (30 MHz \leq Frequency < 1 GHz)
- ≤ -151 dBm/Hz (1 GHz \leq Frequency < 2.4 GHz)
- ≤ -147 dBm/Hz (2.4 GHz \leq Frequency < 3.5 GHz)

With MS2830A-041/043 installed:

- ≤ -144 dBm/Hz (3.5 GHz $<$ Frequency ≤ 6 GHz)

With MS2830A-043 installed

- ≤ -142 dBm/Hz (6 GHz $<$ Frequency ≤ 13.5 GHz)

With MS2830A-062/066, and with MS2830A-008/108, or with Preamplifier turned on:

- ≤ -155 dBm/Hz (1 MHz)
- ≤ -162 dBm/Hz (30 MHz \leq Frequency < 1 GHz)
- ≤ -161 dBm/Hz (1 GHz \leq Frequency < 2 GHz)
- ≤ -158 dBm/Hz (2 GHz \leq Frequency < 3.5 GHz)

With MS2830A-041/043 installed, Frequency Band Mode: Normal

- ≤ -154 dBm/Hz (3.5 GHz $<$ Frequency ≤ 4 GHz)

With MS2830A-041/043 installed, Frequency Band Mode: Spurious

- ≤ -154 dBm/Hz (3.5 GHz $<$ Frequency ≤ 4 GHz)

With MS2830A-041/043 installed,

- ≤ -154 dBm/Hz (4 GHz $<$ Frequency ≤ 6 GHz)

With MS2830A-044/045 installed,

Without MS2830A-067/167/068/168,

- ≤ -134 dBm/Hz (100 kHz)
- ≤ -144 dBm/Hz (1 MHz)
- ≤ -153 dBm/Hz (30 MHz \leq Frequency < 1 GHz)
- ≤ -150 dBm/Hz (1 GHz \leq Frequency < 2.4 GHz)
- ≤ -147 dBm/Hz (2.4 GHz \leq Frequency ≤ 3.5 GHz)
- ≤ -144 dBm/Hz (3.5 GHz $<$ Frequency ≤ 4 GHz)
- ≤ -144 dBm/Hz (4 GHz $<$ Frequency ≤ 6 GHz)
- ≤ -151 dBm/Hz (6 GHz $<$ Frequency ≤ 13.5 GHz)
- ≤ -149 dBm/Hz (13.5 GHz $<$ Frequency ≤ 18.3 GHz)
- ≤ -146 dBm/Hz (18.3 GHz $<$ Frequency ≤ 26.5 GHz)

With MS2830A-045 installed,

- ≤ -146 dBm/Hz (26.5 GHz $<$ Frequency ≤ 34 GHz)
- ≤ -144 dBm/Hz (34 GHz $<$ Frequency ≤ 40 GHz)
- ≤ -140 dBm/Hz (40 GHz $<$ Frequency ≤ 43 GHz)

Without MS2830A-067/167, and with MS2830A-068/168, or with Preamplifier turned off:

- ≤ -134 dBm/Hz (100 kHz)
- ≤ -144 dBm/Hz (1 MHz)
- ≤ -153 dBm/Hz (30 MHz \leq Frequency $<$ 1 GHz)
- ≤ -150 dBm/Hz (1 GHz \leq Frequency $<$ 2.4 GHz)
- ≤ -147 dBm/Hz (2.4 GHz \leq Frequency \leq 3.5 GHz)
- ≤ -144 dBm/Hz (3.5 GHz $<$ Frequency \leq 4 GHz)
- ≤ -144 dBm/Hz (4 GHz $<$ Frequency \leq 6 GHz)
- ≤ -147 dBm/Hz (6 GHz $<$ Frequency \leq 13.5 GHz)
- ≤ -145 dBm/Hz (13.5 GHz $<$ Frequency \leq 18.3 GHz)
- ≤ -141 dBm/Hz (18.3 GHz $<$ Frequency \leq 26.5 GHz)

With MS2830A-045 installed,

- ≤ -141 dBm/Hz (26.5 GHz $<$ Frequency \leq 34 GHz)
- ≤ -135 dBm/Hz (34 GHz $<$ Frequency \leq 40 GHz)
- ≤ -132 dBm/Hz (40 GHz $<$ Frequency \leq 43 GHz)

Without MS2830A-067/167, and with MS2830A-068/168, or with Preamplifier turned on:

- ≤ -156 dBm/Hz (1 MHz)
- ≤ -163 dBm/Hz (30 MHz \leq Frequency $<$ 1 GHz)
- ≤ -161 dBm/Hz (1 GHz \leq Frequency $<$ 2.4 GHz)
- ≤ -159 dBm/Hz (2.4 GHz \leq Frequency \leq 3.5 GHz)
- ≤ -155 dBm/Hz (3.5 GHz $<$ Frequency \leq 4 GHz)
- ≤ -155 dBm/Hz (4 GHz $<$ Frequency \leq 6 GHz)
- ≤ -160 dBm/Hz (6 GHz $<$ Frequency \leq 13.5 GHz)
- ≤ -158 dBm/Hz (13.5 GHz $<$ Frequency \leq 18.3 GHz)
- ≤ -156 dBm/Hz (18.3 GHz $<$ Frequency \leq 26.5 GHz)

With MS2830A-045 installed,

- ≤ -156 dBm/Hz (26.5 GHz $<$ Frequency \leq 34 GHz)
- ≤ -150 dBm/Hz (34 GHz $<$ Frequency \leq 40 GHz)
- ≤ -147 dBm/Hz (40 GHz $<$ Frequency \leq 43 GHz)

With MS2830A-067/167 and without MS2830A-068/168 installed,

- ≤ -147 dBm/Hz (6 GHz $<$ Frequency \leq 13.5 GHz)
- ≤ -145 dBm/Hz (13.5 GHz $<$ Frequency \leq 18.3 GHz)
- ≤ -141 dBm/Hz (18.3 GHz $<$ Frequency \leq 26.5 GHz)

With MS2830A-045 installed,

- ≤ -141 dBm/Hz (26.5 GHz $<$ Frequency \leq 34 GHz)
- ≤ -135 dBm/Hz (34 GHz $<$ Frequency \leq 40 GHz)
- ≤ -132 dBm/Hz (40 GHz $<$ Frequency \leq 43 GHz)

With MS2830A-067/167, and with MS2830A-068/168, or with Preamplifier turned off:

- ≤ -143 dBm/Hz (6 GHz < Frequency \leq 13.5 GHz)
- ≤ -141 dBm/Hz (13.5 GHz < Frequency \leq 18.3 GHz)
- ≤ -137 dBm/Hz (18.3 GHz < Frequency \leq 26.5 GHz)

With MS2830A-045 installed,

- ≤ -137 dBm/Hz (26.5 GHz < Frequency \leq 34 GHz)
- ≤ -131 dBm/Hz (34 GHz < Frequency \leq 40 GHz)
- ≤ -128 dBm/Hz (40 GHz < Frequency \leq 43 GHz)

With MS2830A-067/167, and with MS2830A-068/168, or with Preamplifier turned on:

- ≤ -154 dBm/Hz (6 GHz < Frequency \leq 13.5 GHz)
- ≤ -152 dBm/Hz (13.5 GHz < Frequency \leq 18.3 GHz)
- ≤ -150 dBm/Hz (18.3 GHz < Frequency \leq 26.5 GHz)

With MS2830A-045 installed,

- ≤ -150 dBm/Hz (26.5 GHz < Frequency \leq 34 GHz)
- ≤ -144 dBm/Hz (34 GHz < Frequency \leq 40 GHz)
- ≤ -141 dBm/Hz (40 GHz < Frequency \leq 43 GHz)

(2) Measuring instrument for tests

- Standard terminator
 - (28N50-2) In case of MS2830A-040/041/043/044:
 - (28K50) In case of MS2830A-045:

(3) Setup

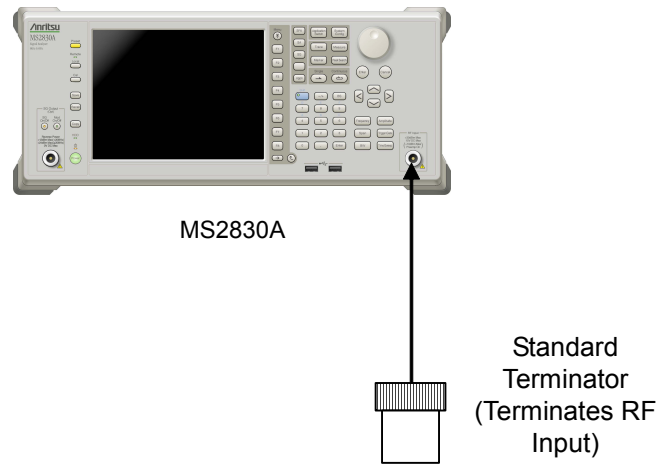











Figure 6.2.6-1 Display average noise level

(4) Notes on test

Perform the test at an ambient temperature of 18 to 28°C and after warming up for at least 30 minutes.



(5) Test procedure

1. Start the application Spectrum Analyzer of the MS2830A.
2. Press  of the MS2830A.
3. Press  (Preset).
4. Press  and then  (SIGANA All).
5. Terminate the RF input with the standard terminator.
6. Set as follows for the MS2830A (time domain mode).

Center Freq	100 kHz
Span	0 Hz
Reference Level	-100 dBm
RBW	1 kHz
VBW	1 Hz
VBW Mode	Video
Attenuator	0 dB
Detection	Sample
Sweep Time	1 s
7. Press .
8. Press  (Trace-A Storage Mode) then select  (Average).
9. Press  to return to the original page.
10. Press  (Storage Count).
11. Set the average count to 16 times.

12. Press  (Single) to start averaging then wait until the sweep for an average count of 16 times is completed.
13. Using the burst average measurement function, set the Start Time and Stop Time parameters as follows and measure the level.

Start Time	100 ms
Stop Time	900 ms
14. The (Burst average measurement value [dBm] –30 dB) will be the display average noise level (dBm/Hz).
15. Set the center frequency according to the Display Average Noise Level table in Appendix A, then obtain the display average noise level according to Steps 7 to 14.
16. Set this instrument as shown below, only when Preamplifier option is installed:

Press  to display the amplitude menu, and then press  (Pre-amp) to set the pre-amplifier settings to On.

Calculate the display average noise level, according to steps 11 to 15.

6.2.7 Second harmonic wave distortion

A harmonic wave is generated and displayed on the screen due to analyzer input mixer nonlinearity even when an input signal without harmonic wave distortion is applied to the spectrum analyzer.

The second harmonic wave level will be the highest among the harmonic waves displayed on this screen.

For the test method point, apply a distortion signal (at least 20 dB) lower than the internal harmonic wave of the MS2830A then measure the level difference between the fundamental wave and the second harmonic wave. In the event a low distortion signal source cannot be obtained, apply a low distortion signal to the MS2830A after passing through LPF.

(1) Test Target Standards

- Second harmonic wave distortion

■ MS2830A

With MS2830A-040/041/043 installed,

Without MS2830A-008/108 or with Preamp turned off, and at Attenuator Mode = Mechanical Atten Only

At mixer input level: -30 dBm:

≤ -60 dBc (10 MHz ≤ Input frequency ≤ 300 MHz)

≤ -65 dBc (300 MHz ≤ Input frequency ≤ 1 GHz)

≤ -65 dBc (1 GHz < Input frequency ≤ 2 GHz)

At mixer input level: -10 dBm:

≤ -70 dBc (2 GHz < Input frequency ≤ 3 GHz, Frequency Band Mode: Normal)

≤ -70 dBc (1.75 GHz ≤ Input frequency ≤ 3 GHz, Frequency Band Mode: Spurious)

At mixer input level: -10 dBm:

≤ -70 dBc (3 GHz ≤ Input frequency ≤ 6.75 GHz)

With MS2830A-008/108 or with Preamp turned on, and at Attenuator Mode = Mechanical Atten Only:

At preamplifier input level: -45 dBm:

≤ -50 dBc (10 MHz ≤ Input frequency ≤ 300 MHz)

≤ -55 dBc (300 MHz < Input frequency ≤ 3 GHz)

With MS2830A-044/045

Without MS2830A-008/108/068/168 and MS2830A-067/167, and at Attenuator Mode = Mechanical Atten Only:

At mixer input level -30 dBm

≤ -60 dBc (10 MHz ≤ Input frequency ≤ 300 MHz)

≤ -65 dBc (300 MHz < Input frequency ≤ 1 GHz)

≤ -65 dBc (1 GHz < Input frequency ≤ 2 GHz, Frequency Band Mode: Normal)

≤ -65 dBc (1 GHz < Input frequency \leq 1.75 GHz, Frequency Band
Mode: Spurious)

At mixer input level -10 dBm

≤ -70 dBc (2 GHz < Input frequency \leq 3 GHz, Frequency Band
Mode: Normal)

≤ -70 dBc (1.75 GHz \leq Input frequency \leq 3 GHz, Frequency Band
Mode: Spurious)

≤ -90 dBc (3 GHz \leq Input frequency \leq 6.75 GHz)

With MS2830A-068/168 and with Preamplifier turned off:

Or with MS2830A-067/167 and with Microwave Preselector Bypass
turned off and at Attenuator Mode = Mechanical Atten Only:

At mixer input level -30 dBm

≤ -60 dBc (10 MHz \leq Input frequency \leq 300 MHz)

≤ -65 dBc (300 MHz < Input frequency \leq 1 GHz)

≤ -65 dBc (1 GHz < Input frequency \leq 2 GHz, Frequency Band
Mode: Normal)

≤ -65 dBc (1 GHz < Input frequency \leq 1.75 GHz, Frequency Band
Mode: Spurious)

At mixer input level -10 dBm

≤ -70 dBc (2 GHz < Input frequency \leq 3 GHz, Frequency Band
Mode: Normal)

≤ -70 dBc (1.75 GHz \leq Input frequency \leq 3 GHz, Frequency Band
Mode: Spurious)

≤ -70 dBc (3 GHz \leq Input frequency \leq 6.75 GHz)

With MS2830A-008/108/068/168 or with Preamplifier turned on, and at
Attenuator Mode = Mechanical Atten Only:

At mixer input level -45 dBm

≤ -50 dBc (10 MHz \leq Input frequency \leq 300 MHz)

≤ -55 dBc (300 MHz < Input frequency \leq 2 GHz)

≤ -45 dBc (2 GHz < Input frequency \leq 6.75 GHz)

(2) Measuring instrument for tests

- Signal generator (MG3700A) : Up to 6 GHz
MG3692C: from 6 GHz
- LPF: Items capturing an 40 dB attenuator or higher at a frequency 2
times the fundamental wave

(3) Setup

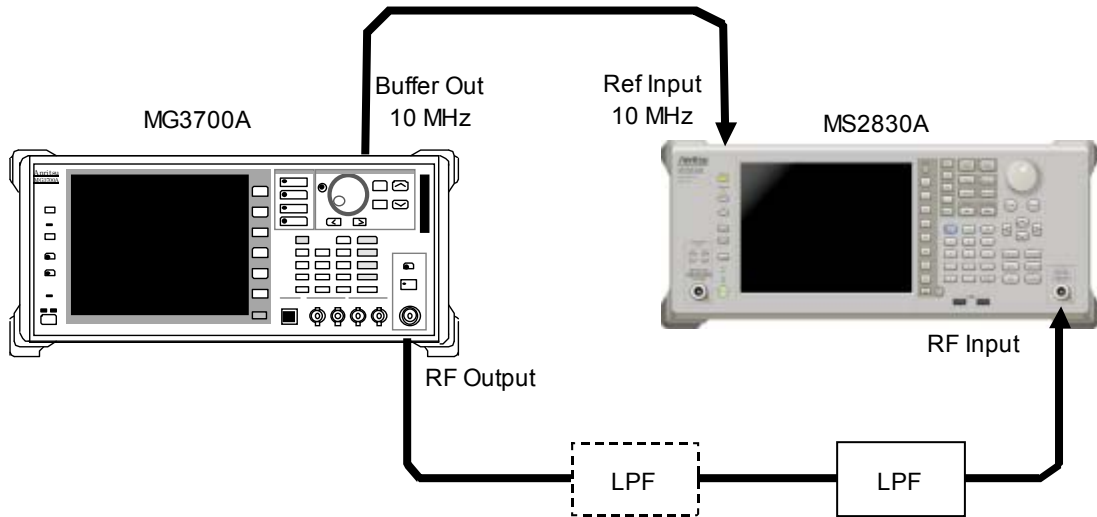





Figure 6.2.7-1 Second harmonic wave distortion test

(4) Notes on test

Perform the test at an ambient temperature of 18 to 28°C and after warming up for at least 30 minutes.

(5) Test procedure

1. Start the application Spectrum Analyzer of the MS2830A.
2. Press  of the MS2830A.
3. Press  (Preset).
4. Press  then  (SIGANA All).
5. Set as follows for the MS2830A:

Span	50 kHz
RBW	1 kHz
VBW	1 kHz
Attenuator	10 dB
Det Mode	Positive
Sweep Time	150 ms
6. Set the output level of the MG3700A to -20 dBm.
7. Connect LPF according to the Second Harmonic Wave Distortion table in Appendix A. If LPF attenuation is insufficient, use LPF in 2 stages.
8. Set the output frequency of the MG3700A and center frequency of the MS2830A, and reference level, according to the Second Harmonic Wave Distortion table in Appendix A.

9. Adjust the output level of the signal generator so as to get the peak point of the spectrum waveform into the range of ± 0.06 dB.
10. Press **Peak Search** to perform a peak search. Set so as to include the signal trace peak point to the zone marker.
11. Press **Marker** to display the Marker function menu, and then press **F2** (Delta) to set to the delta marker.

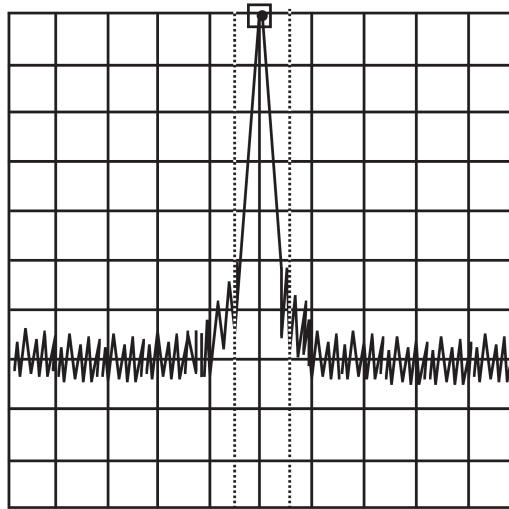

Figure 6.2.7-2 Fundamental wave

12. In order to display the second harmonic wave on the screen, set twice as much frequency as the center frequency. Delta marker level reading indicates the level difference between the fundamental wave and the second harmonic wave.
In the event the level difference is 80 dB or higher, set the reference level to -50 dBm. Check whether the setting value of the input attenuator is 10 dB.

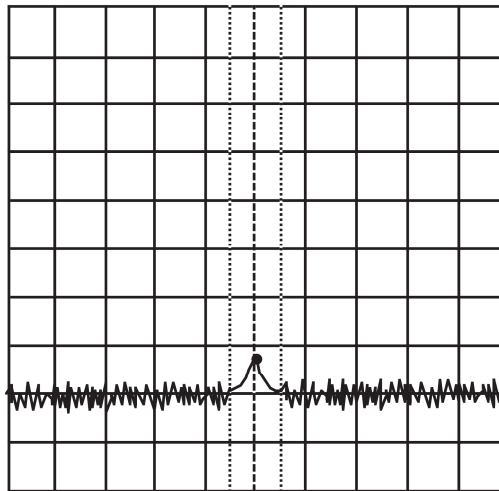

Figure 6.2.7-3 Second harmonic wave

13. Repeat Steps 7 to 12, according to the Second Harmonic Wave Distortion table in Appendix A.
14. When the Preamplifier option is installed
Press Amplitude and turn on the preamplifier by pressing F4 (Pre-amp). Follow the same procedure as shown in 1 to 5 above, and then set the MG3700A output level to -35 dBm.
15. Measure the 2nd harmonic wave distortion when the preamplifier is on by using the procedure shown in 7 to 13 above.

Chapter 7 Power Meter

This chapter describes basic operations of the power meter functions.

7.1	Power Meter.....	7-2
7.2	Display Description	7-3
7.3	Function Menu	7-5
	7.3.1 Setting the frequency.....	7-6
	7.3.2 Level setting	7-7
	7.3.3 Measure.....	7-9
	7.3.4 Accessory	7-10
	7.3.5 Power Meter	7-11
7.4	Initialization	7-14
	7.4.1 Preset	7-14
	7.4.2 Default value list	7-14

7.1 Power Meter

You can connect a USB power sensor to the MS2830A and read the measurement values.

Preparation

For the setup procedure of the application software for this function, refer to Section 3.8 “Installing and Uninstalling” and Section 3.5 “Loading, Unloading, and Switching Applications.”

The MS2830A can accept any USB power sensor in the following table, automatically recognize its model name, and automatically set the COM Port regardless of the USB Port to which the USB power sensor is connected.

Table 7.1-1 shows the models and specifications of compatible power sensors.

Table 7.1-1 USB Power Sensors

Model	Frequency	Resolution	Dynamic Range
MA24104A	600 MHz to 4 GHz	1 kHz	+3 dBm to +51.76 dBm
MA24106A	50 MHz to 6 GHz	1 kHz	-40 dBm to +23 dBm
MA24108A	10 MHz to 8 GHz	100 kHz	-40 dBm to +20 dBm
MA24118A	10 MHz to 18 GHz	100 kHz	-40 dBm to +20 dBm
MA24126A	10 MHz to 26 GHz	100 kHz	-40 dBm to +20 dBm

Follow the procedure below to select a USB power meter function:

<Procedure>

1. Plug in the USB power sensor connector to the USB port of the MS2830A Signal Analyzer.
2. Press  to display the Application Switch function menu.
3. Press the Power Meter function key.

You can select the application also by clicking the Power Meter icon on the task bar.

7.2 Display Description

Press  to display the Application Switch function menu. Then, select the Power Meter, and you can display the power meter application main screen and the function menu.

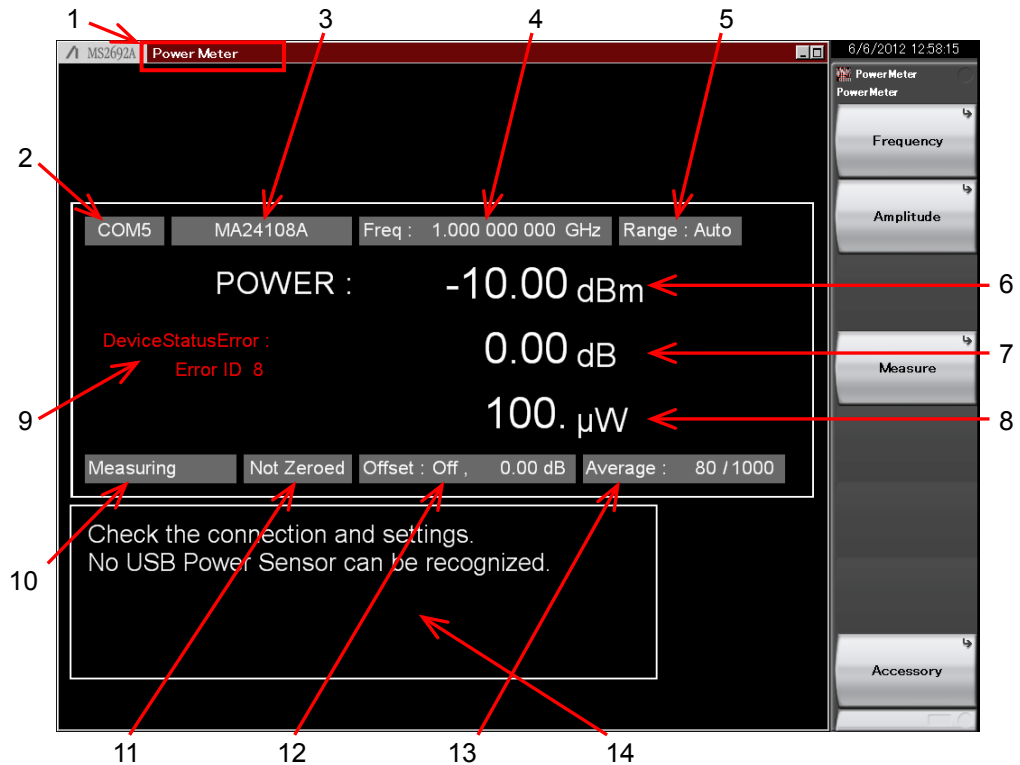



Figure 7.2-1 Power meter application main screen

Table 7.2-1 Parameters on the power meter application main screen

No.	Display	Description
1	Power Meter	Application software name The name of the synchronizing application is displayed in parentheses.
2	COMxx	COM Port number (xx) to which the USB power sensor is connected.
	Port	Appears when no USB power sensor is connected.
3	MAxxxxxA	Model of the connected USB power sensor.
	Model	Appears when no USB power sensor is connected.
4	Frequency	Calibration factor frequency setting.
5	Auto	Input range: Auto
	Low	Input range: Low input level
	High	Input range: High input level
6	Power [dBm]	Measured power with offset level in dBm units. This value is displayed in red in case of a device status error.
7	Relative Power [dB]	Relative power in dB units.
8	Power [W]	Measured power with offset level in W units.
9	Device Status Error	Appears in case of a power sensor error.*
10	Measuring	Measurement is in progress.
	COM Searching	USB power sensor search in progress.
	Stop	USB power sensor search stopped.
11	Not Zeroed	Zeroing not executed.
	Zeroed	Zeroing executed.
12	Offset	Sets the offset level value to be added to the power sensor reading and turns on and off the offset function.
13	Average	Current count / Setting count of averaging. Appears when the Average is turned on.  7.3.5 "Power Meter"
14	Disconnect Info	Appears when no power sensor is connected or the connected power sensor is not recognized by the mainframe. If the power sensor is connected, disconnect it from the USB port and securely connect again.

*: For detailed information on error causes and Error IDs, refer to Chapter 13-3 "STATUS?" in "User Guide, Anritsu Power Xpert and USB Power Sensors."

7.3 Function Menu





Press  when the Power Meter function to display the Power Meter function menu.

Table 7.3-1 Power Meter function menu

Function Key	Menu Display	Function
F1	Frequency	Opens the Frequency function menu.  7.3.1 "Setting the frequency"
F2	Amplitude	Opens the Amplitude function menu.  7.3.2 "Level setting"
F4	Measure	Opens the Measure function menu.  7.3.3 "Measure"
F8	Accessory	Opens the Accessory function menu.  7.3.4 "Accessory"

7.3.1 Setting the frequency

In the Frequency function menu, you can set the calibration factor frequency of the USB power sensor.

Press  (Frequency) in the Power Meter function menu to display the Frequency function menu.

Table 7.3.1-1 Frequency function menu

Function Key	Menu Display	Function
F1	Frequency	Sets the calibration factor frequency of the power sensor.



Press  (Frequency) in the Frequency function menu or  to display the Frequency dialog box, and then set the measurement frequency.

Table 7.3.1-2 USB Power Sensor

Model	Setting range	Resolution
Disconnected	10MHz to 26 GHz	1 Hz
MA24104A	600 MHz to 4 GHz	1 kHz
MA24106A	50 MHz to 6 GHz	1 kHz
MA24108A	10 MHz to 8 GHz	100 kHz
MA24118A	10 MHz to 18 GHz	100 kHz
MA24126A	10 MHz to 26 GHz	100 kHz

Note:

The values below resolutions are rounded.

7.3.2 Level setting



Press  (Amplitude) or  in the Power Meter function menu to display the Amplitude function menu.

Table 7.3.2-1 Amplitude function menu

Function Key	Menu Display	Function
F1	Range	Opens the Range function menu.
F7	Offset (On/Off)	Turns on and off the level offset function.
F8	Offset Value	Sets the level offset value.

Setting the range

Press  (Range) in the Amplitude function menu to display the Range function menu.

You can select the measurement range of the power sensor among Auto, High, and Low. (High and Low require manually setting.)

Note:

This parameter is always Auto when the model is MA24104A or MA24106A.

Table 7.3.2-2 Range function menu

Function Key	Menu Display	Function
F1	Auto	Automatic setting (Default)
F2	Low	When the model is MA24108A, MA24118A, or MA24126A: Input range: -40 dBm to -7 dBm
F3	High	When the model is MA24108A, MA24118A, or MA24126A: Input range: -7 dBm to +20 dBm

Setting the level offset

An arbitrary offset value is added to the measurement value, and their sum is displayed.

Press **F7** (Offset) in the Amplitude function menu to turn on and off the addition of the offset value.

Offset: Level offset

- On Turns on the addition of the offset value.
- Off Turns off the addition of the offset value (Default).

Press **F8** (Offset Value) in the Amplitude function menu to display the Offset Value dialog box, and then set the offset value.

Offset Value:

Setting range and minimum resolution of level offset

- Setting range -100.00 to 100.00 dB
- Resolution 0.01 dB
- Default 0.00 dB

When this function is used, the displayed power sensor value is offset with the value specified in the Offset Value dialog box. It is used when the path loss or gain from the MS2830A to DUT is corrected.

$$[\text{Power sensor reading after offset}] = [\text{Power sensor reading}] + [\text{Offset level}]$$

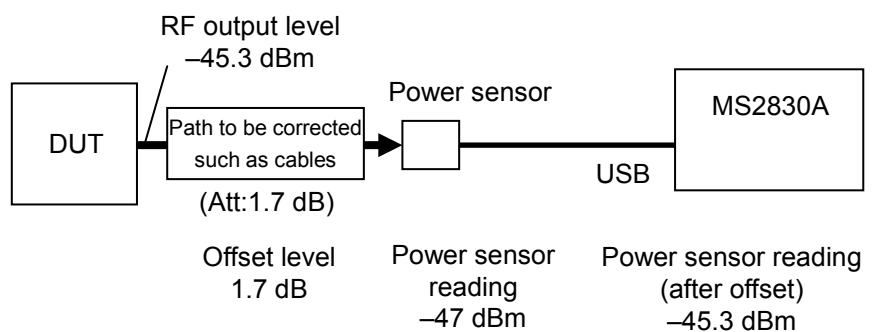



Figure 7.3.2-1 Summary of offset level

7.3.3 Measure

Press  (Measure) or  in the Power Meter function menu to display the Measure function menu.

The Measure function menu items depend on whether the Power Meter application synchronizes with the other application or not.

When not synchronizing with any applications

Table 7.3.3-1 Measure function menu

Function Key	Menu Display	Function
F1	Power Meter	Opens the Power Meter function menu.  7.3.5 "Power Meter"

When synchronizing with the application

Table 7.3.3-2 Measure function menu

Function Key	Menu Display	Function
F1	Modulation Analysis	Displays the application software that is synchronizing.
F2	Power Meter	Opens the Power Meter function menu.  7.3.5 "Power Meter"

Application synchronization

Application synchronization refers to a state in which the Power Meter application is selected in the Measure function menu of the other measurement application software. In this case, the parameters such as Frequency are shared between 2 applications and do not require setting again when switching the applications.

Table 7.3.3-3 Items to be synchronized between applications

Application Software	Items to be synchronized	
Vector Modulation Analysis	Frequency	Frequency
	Offset	On/off state of the level offset function
	Offset Value	Level offset value

When the application synchronization is enabled, the title bar displays "Power Meter (Application name)."

7.3.4 Accessory

Press  (Accessory) in the Power Meter function menu to display the Accessory function menu.





Table 7.3.4-1 Accessory function menu

Function Key	Menu Display	Function
F1	Title	Sets the title character string.
F2	Title (On/Off)	Turns on and off the title character string display.



Setting the title

A title consisting of up to 32 characters can be displayed on the screen. (Up to 17 characters can be displayed on the top of the function menu. The maximum character length depends on characters.)

<Procedure>

1. Press  (Accessory) in the Power Meter function menu.
2. Press  (Title) to display the character string input dialog box. Use the rotary knob to select the characters, and press  to enter them. When the title is entered, press  (Set).
3. Press  (Title On/Off) to select Off, and the title display is turned off.

7.3.5 Power Meter

Press  or  (Power Meter) in the Measure function menu.

In the Power Meter menu, you can set the measurement that is performed by using the USB power sensor.

Table 7.3.5-1 Power Meter function menu

Function Key	Menu Display	Function
F1	Average	Turns on and off the function of averaging the measurement results.
F2	Average Count	Sets the number of times the measurement results are averaged.
F3	Set Reference	Sets the “measurement value after offset and averaging” as the reference level of the relative power.
F6	Zero Sensor	Executes the zeroing of the USB power sensor.
F8	Back To Application	Appears only during application synchronization. Activates the synchronizing measurement application software.

Averaging

Press  (Average) in the Power Meter function menu to turn on and off the averaging function.

Average: Turns on and off the function of averaging .

On Turns on the averaging function.

Off Turns off the averaging function (Default).

Press  (Average Count) in the Power Meter function menu to display the Average Count dialog box, and then set the number of averaging times.

Averaging Count: Sets the number of averaging times.

Setting range 2 to 1000

Resolution 1

Default 10

Setting the reference level

Press  (Set Reference) in the Power Meter function menu to set the “measurement value after offset and averaging” as the reference level of the relative power.

Zeroing the USB power sensor

Press  (Zero Sensor) in the Power Meter function menu to execute the zeroing.

When you execute the function, a progress dialog box appears.

Please do not operate the MS2830A during the zeroing.

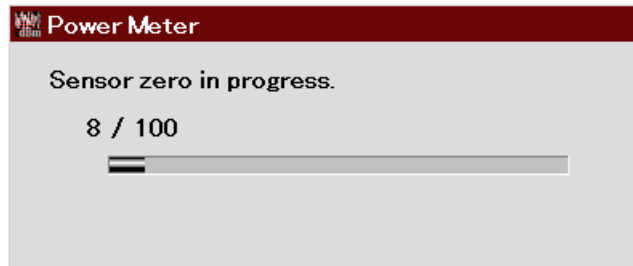

Figure 7.3.5-1 “Power Meter zeroing” dialog box (Progress)

If the zeroing fails, the following dialog box appears.

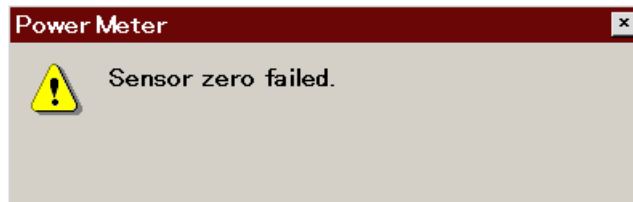

Figure 7.3.5-2 “Power Meter zeroing” dialog box (Zeroing failed)

Zeroing the power sensor

<Procedure>

1. Plug in the USB power sensor connector to the USB port of the MS2830A Signal Analyzer.
2. Turn off the RF output of DUT (device under test) in advance. Connect the RF Input connector of the power sensor to the RF output terminal of DUT.



CAUTION

Avoid excessive input levels when connecting the power sensor to DUT(device under test). The power sensor may be damaged depending on output levels of DUT.

3. Execute the Zero Sensor menu.

Activating the synchronizing application

Press  (Back To Application) in the Power Meter function menu to return to the synchronizing application software.

7.4 Initialization

7.4.1 Preset

Power Meter function is a kind of application. For the presetting procedure, refer to Section 3.7.1 “Preset.”

7.4.2 Default value list

This section lists the default values of the Power Meter function.

Frequency	1 GHz
Level Offset State	Off
Level Offset Value	0.00 dB
Average State	Off
Average Count	10
Reference Level	0.00 dBm
Reference Level Set	Off
Range	Auto
Sensor Connected	Disconnected
Sensor Model	Disconnected

Chapter 8 BER Measurement Function

This chapter describes the operation methods for the BER measurement function of the MS2830A-026/126.

Note:

This application is available only when MS2830A-026/126 is installed.

8.1	Outline of BER Measurement	8-2
8.2	Display Description	8-5
8.3	BER Measurement Function Menu.....	8-9
8.4	Connecting MS2830A-026/126 to External System ...	8-11
8.5	Performing BER Measurement.....	8-12
8.6	Setting Automatic Resynchronization Function	8-22
8.7	Setting Input Interface.....	8-27
8.8	Setting PN_Fix Pattern	8-28
8.9	Setting User-defined Pattern	8-34
8.10	Description of BER Measurement Operation	8-42

8.1 Outline of BER Measurement

The MS2830A-026/126 can measure the bit error rate (BER) of signals incoming from external systems. By pressing the Application Switch and then BER Test, the MS2830A-026/126 can be switched to BER measurement mode.

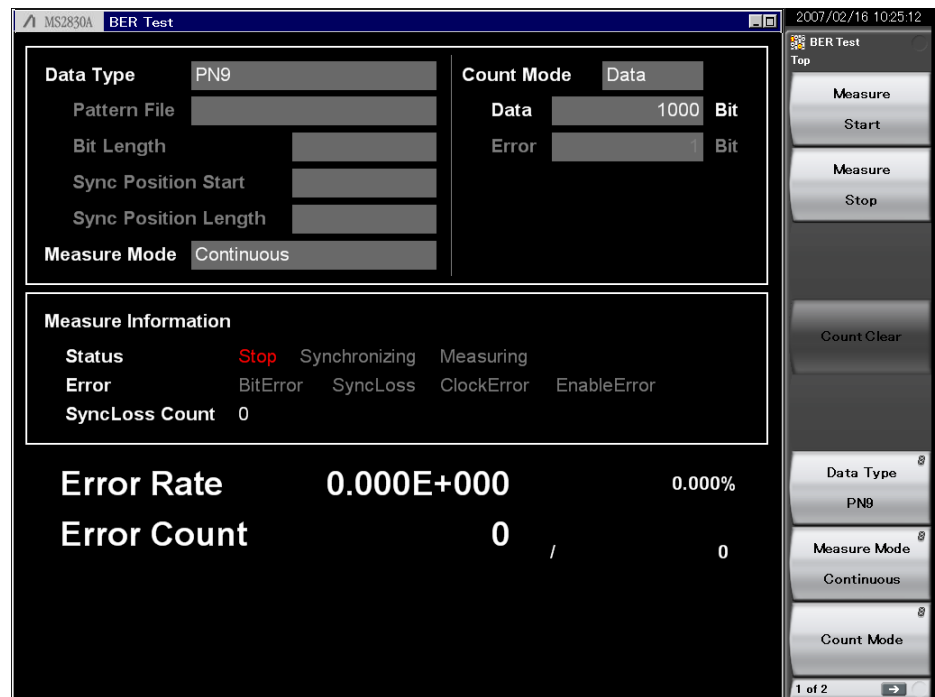

Figure 8.1-1 BER function main screen

Features of the MS2830A-026/126 BER measurement function are as listed below:

Input signals

Data, Clock, Enable

(Polarity inversion is enabled.)

Input level

TTL level

Measurement bit rate

100 bps to 10 Mbps

Measured pattern

PN9, PN11, PN15, PN20, PN23, ALL0, ALL1, repetition of 01, PN9Fix, PN11Fix, PN15Fix, PN20Fix, PN23Fix, and user-defined patterns

Measurement bit count

1000 to 4294967295 bits ($2^{32} - 1$ bits)

Measurement error bit count

1 to 2147483647 bits ($2^{31} - 1$ bits)

The maximum value that can be set as the measurement error bit count is ($2^{31} - 1$ bits). If Count Mode is set to Data, however, counting of the error bit count will continue even if ($2^{31} - 1$ bits) is exceeded.

Operation modes

Auto Resync: On, Off
 Measure Mode: Continuous, Single, Endless
 Count Mode: Data, Error

Synchronization conditions

Depends on the measurement pattern.

PN 9, 11, 15, 20, 23:	No errors occur for (PN stage count × 2) consecutive bits
ALL0, ALL1, repetition of 01:	No errors occur for 10 consecutive bits
PN_Fix pattern:	See Section 8.1.8.
User-defined pattern:	No errors occur during the period that is set for synchronization judgment



Synchronization probability

The condition required for MS2830A-026/126 to synchronize with a PN signal is that no error occurs for (PN stage count × 2) consecutive bits. The table below lists the probabilities that no error will occur for (PN stage count × 2) consecutive bits for a PN signal that includes random errors. These probabilities thus can be referred to as the probabilities that the MS2830A-026/126 synchronizes with a PN signal at a certain error rate in one cycle.

Table 8.1-1 Probabilities that MS2830A-026/126 synchronizes with PN signal

PN stage counts Error rate of PN signal (%)	PN9	PN15	PN23
10	15.0	4.2	0.79
3	57.8	40.1	24.6
1	83.5	74.0	63.0
0.1	98.2	97.0	95.5

SyncLoss detection condition

The SyncLoss detection condition can be changed. However, SyncLoss detection is not executed if Auto Resync is set to Off.

8.2 Display Description

This section describes the BER measurement function display items.

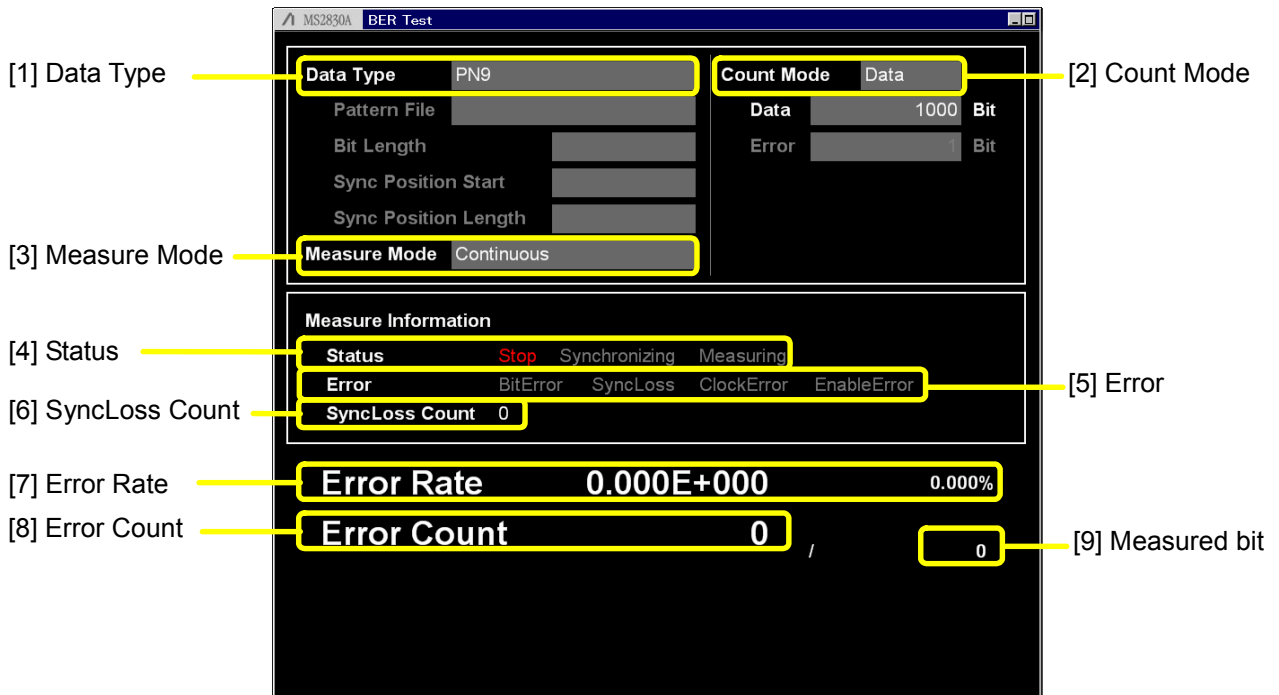

Figure 8.2-1 BER main screen

Table 8.2-1 Display items in BER measurement mode

No.	Display	Description
[1]	Data Type	<p>Displays the names of data selected on the list selection popup screen. Characters cannot be directly entered. Displays the data set on the data input screen.</p> <p>When User Pattern is selected in the data settings, parameters related to the loaded User Pattern are displayed.</p> <ol style="list-style-type: none"> 1) Pattern File Displays the name of the loaded User Pattern. 2) Bit Length Displays the length (bit count) of the loaded User Pattern. 3) Sync Position Start Displays the bit at which synchronization of the User Pattern will be started. 4) Sync Position Length Displays the length (bit count) which is compared when synchronizing the User Pattern.
[2]	Count Mode	<p>Characters cannot be directly entered. The count mode set in the setup screen will be displayed.</p> <ol style="list-style-type: none"> 1) Count Mode Displays the count mode set on the input screen. 2) Bit length Displays the bit length of Data and Error set on the input screen.
[3]	Measure Mode	<p>Displays the measurement mode selected in the list selection popup screen. Characters cannot be directly entered. Displays the data set in the data setup screen.</p>

Table 8.2-2 Display items in Measure Information area

No.	Display	Description
[4]	Status	Displays Stop, Synchronizing, and Measuring.
[5]	Error	<p>These messages light up when the following errors occur.</p> <p>BitError: Error bit occurrence SyncLoss: SyncLoss occurrence ClockError: Input clock signal failure EnableError: Input enable signal failure</p> <p>Displays OverflowDataCount or OverflowSyncLoss when the following errors occur.</p> <p>OverflowDataCount: The number of received bits exceeds the maximum value ($2^{32} - 1$ bits).</p> <p>OverflowSyncLoss: The number of SyncLoss errors exceeds the maximum value (65535).</p>
[6]	SyncLoss Count	Displays the number of SyncLoss errors.

Table 8.2-3 Error rate display

No.	Display	Description
[7]	Error Rate	Displays the error rate.
[8]	Error Count	Displays the error count.
[9]	Bit	Displays the number of measured bits.

Error Rate display

Error Rate may be displayed in either floating-point form or fixed-point percentage, which complies with the following rules:

- Floating-point display

Rounding down to the 1/10000th digit from the maximum significant value, the digits up to the 1/1000th digit are displayed.

Example: For 0.00978495
→ Displayed as 9.785E-003.

- Fixed-point percentage display

The value is displayed in percentage. With the fourth digit of the fraction part rounded, the digits down to the third digit of the fraction part are displayed.

Example: For 0.00978495
→ Displayed as 0.978%.

If BER measurement has not yet been performed, the error rate, error count, and received bits count are all displayed as 0.

8.3 BER Measurement Function Menu

This section describes the main function menu on the BER measurement screen.

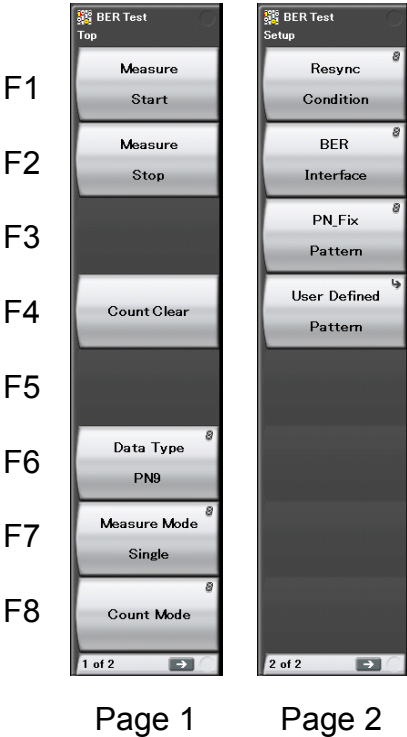











Figure 8.3-1 Main function menu

Table 8.3-1 Top function menu

Menu Display	Function
Measure Start	Starts BER measurement.  8.5 "Performing BER Measurement"
Measure Stop	Stops BER measurement.  8.5 "Performing BER Measurement"
Count Clear	Clears the count operation.  8.5 "Performing BER Measurement"
Data Type	Selects the data type.  8.5 "Performing BER Measurement"
Measure Mode	Selects the BER measurement mode.  8.5 "Performing BER Measurement"
Count Mode	Selects the measurement termination condition and specifies the bit count.  8.5 "Performing BER Measurement"
Resync Condition	Sets the automatic resynchronization function.  8.6 "Setting Automatic Resynchronization Function"
BER Interface	Performs settings related to the BER measurement interface.  8.7 "Setting Input Interface"
PN_Fix Pattern	Sets PN fix.  8.8 "Setting PN_Fix Pattern"
User Defined Pattern	Displays the Pattern Load function menu.  8.9 "Setting User-defined Pattern"

8.4 Connecting MS2830A-026/126 to External System

To perform BER measurement, signals must be input from an external system. Signals can be input from the AUX connector on the rear panel.

Details of BER signal input

The following are signal pins used for BER measurement.

- BER_CLK Inputs a clock signal that is generated in sync with data.
- BER_DATA Inputs the data signal.
- BER_EN Inputs the gate (enable) signal.

Refer to Table 3.1.1-1 “AUX Connector” for details on pin assignment.

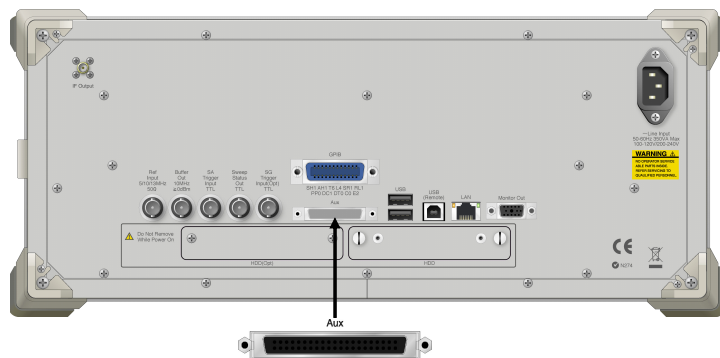

Figure 8.4-1 Input connector

If the enable signal is not used, set “Enable Active” to “Disable.”

Change the settings of the MS2830A-026/126 in accordance with the specifications of the input signal.

 8.7 “Setting Input Interface”

8.5 Performing BER Measurement

This function performs various BER measurement settings, and executes the measurement.

BER measurement

<Procedure>

1. Input the signals from the external system according to the instructions in Section 8.4 “Connecting MS2830A-026/126 to External System.”
2. Select the data type. Press **F6** (Data Type) to display the Data Type selection window. Move the cursor to the pattern to be used for the measurement and press **F7** (Set) to select a pattern.

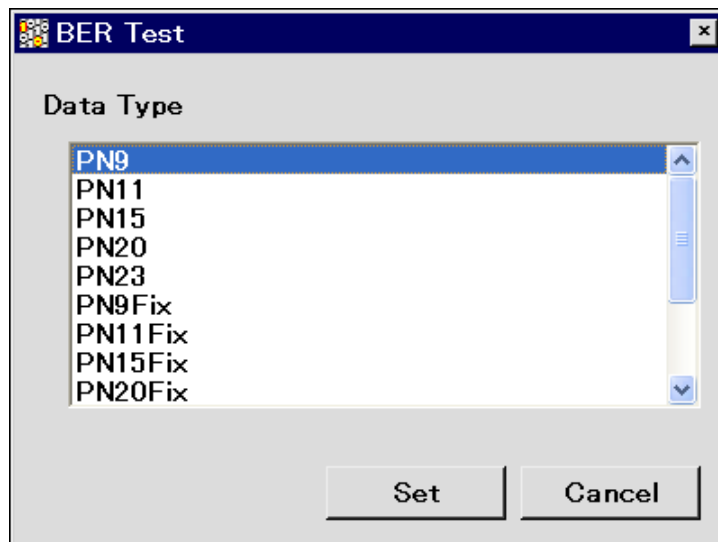



Figure 8.5-1 Data Type selection window

The following patterns can be selected.

PN9, PN11, PN15, PN20, PN23,
PN9Fix, PN11Fix, PN15Fix, PN20Fix, PN23Fix,
ALL0, ALL1, ALT(0/1), UserDefine

ALT(0/1) indicates a repetition pattern of 0 and 1.

For details on PN_Fix and UserDefine, refer to the following sections respectively:

 8.8 “Setting PN_Fix Pattern”

 8.9 “Setting User-defined Pattern”

- 3. Select BER measure mode. Press **F7** (Measure Mode) to display the Measurement Mode selection window. Move the cursor to the desired measurement mode and press **F7** (Set) to select it.

One of the following three types can be selected for the measurement mode:

- Continuous Performs the measurement continuously for the set bit count or set error bit count.
- Single Performs the measurement for the set bit count or set error bit count.
- Endless Performs the measurement for 4294967295 bits.

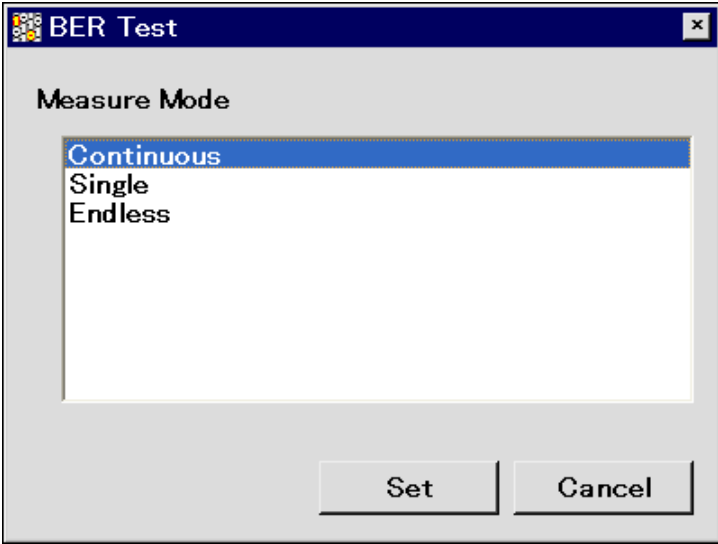

Figure 8.5-2 Measurement Mode selection window

When “Endless” is selected for the measurement mode, the count mode (Count Mode), data bit (Data), and the display of error bit (Error) setting items is darkened.

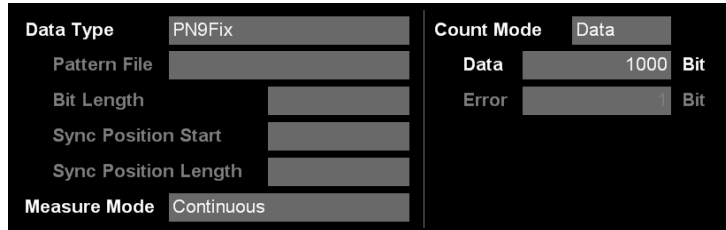

Figure 8.5-3 When Single or Continuous is selected

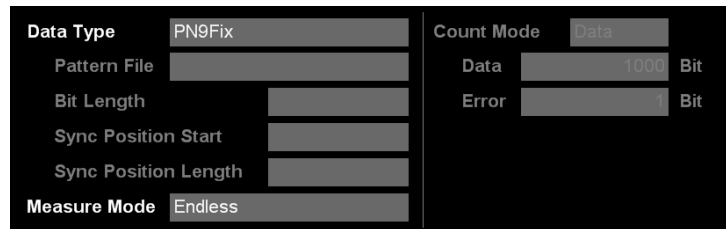

Figure 8.5-4 When Endless is selected

- 4. Select the measurement termination condition.
This item cannot be set when Endless is selected.
Press **F8** (Count Mode) to display the Measurement termination condition setup window. Move the cursor to the desired measurement termination condition and press **F7** (Set) to select it.
Either of the following two types can be selected for the measurement termination condition:
Data Specify measurement bit count. → Go to Step 5.
Error Specify measurement error bit count. → Go to Step 6.

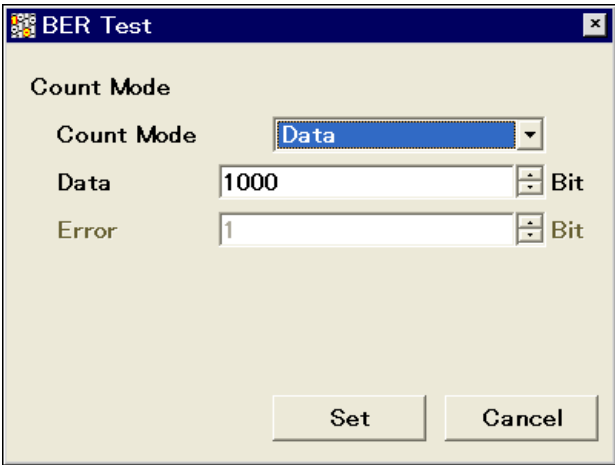

Figure 8.5-5 Measurement termination condition selection window

- 5. Set the measurement bit count.
This item cannot be set when Endless is selected.
When Count Mode is set to Data, the value in Data Bit can be changed. Set the measurement bit count using the numeric keypad, rotary knob, or **↑** **↓**. Then press **F7** (Set) to set the measurement bit count. The measurement is stopped when the accumulated measurement bit count reaches the set bit count. → Go to Step 7.

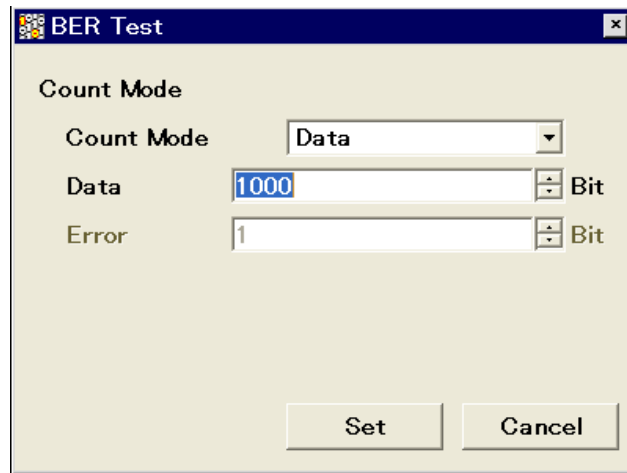





Figure 8.5-6 Measurement bit count setup window

Measurement bit count setting range: 1000 to 4294967295 bits

6. Set the measurement error bit count.
This item cannot be set when Endless is selected.
When Count Mode is set to Error, the value in Error Bit can be changed. Specify the measurement error bit count using the numeric keypad, rotary knob, or  . Then press  (Set) to count the measurement error bit count. The measurement is stopped when the accumulated measurement error bit count reaches the set bit count.

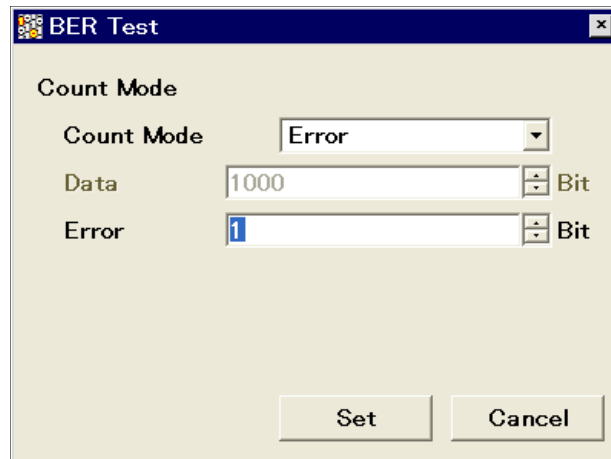



Figure 8.5-7 Measurement error bit count setup window

Measurement error bit count setting range: 1 to 2147483647 bits

- Configure settings for the automatic resynchronization function. The automatic resynchronization function can be enabled/disabled and the SyncLoss error judgment condition can be set. Refer to the following section for details on the settings.

 8.6 “Setting Automatic Resynchronization Function”

- Press the  (Measure Start) panel key to start BER measurement. If  (Measure Stop) is pressed while BER measurement is in progress, the operation is stopped.

Operation termination conditions differ depending on the operation mode.



Press  to perform BER measurement in Single measurement mode. Press  to perform BER measurement in Continuous measurement mode. If measurement is started using these panel keys, the BER measurement mode settings will be switched automatically.

Table 8.5-1 Operation termination conditions for BER measurement (Single measurement mode)

Auto Resync / Count Mode	On	Off
Data	<ul style="list-style-type: none"> The set measurement bit count is reached. The SyncLoss count reaches the maximum value (65535). 	<ul style="list-style-type: none"> The set measurement bit count is reached.
Error	<ul style="list-style-type: none"> The set measurement error bit count is reached. The measurement bit count reaches the maximum value ($2^{32} - 1$ bits). The SyncLoss count reaches the maximum value (65535). 	<ul style="list-style-type: none"> The set measurement error bit count is reached. The measurement bit count reaches the maximum value ($2^{32} - 1$ bits).

Measurement is stopped when setting parameters (except for BER Interface).

If a condition listed in Table 8.5-1 above is met in the Continuous measurement mode, measurement is stopped once and then started again.

Measurement continues even if the view moves to another screen while BER measurement is in progress.

If the power is turned off while BER measurement is in progress, the measurement will remain stopped.

When measurement is started with a 10 Mbps signal, the upper limit of the measurement bit count is reached about 430 seconds (max.) later, and measurement is stopped.

BER measurement will be stopped if any of the following operations is performed when the Option 077/177 Analysis Bandwidth Extension to 62.5 MHz, or Option 078/178 Analysis Bandwidth Extension to 125MHz is installed in the MS2830A.

- Switching the frequency span of the signal analyzer function to 31.25 MHz or less (lower) and to 50 MHz or more (upper).

- Switching the application to/from the spectrum analyzer function when the frequency span of the signal analyzer is set to 50 MHz or more.

- Switching the application to/from measurement software when the frequency span of the signal analyzer is set to 50 MHz or more.

Display in each BER measurement mode

The following figures show the difference in the measurement display among BER measurement modes. For the progress state and error rate display during measurement, see Figure 8.2-1 “BER main screen”.

Measurement Mode: Continuous

The Measured result is not updated during measurement. When the measurement is completed, the measured result is updated and the measurement then starts again.

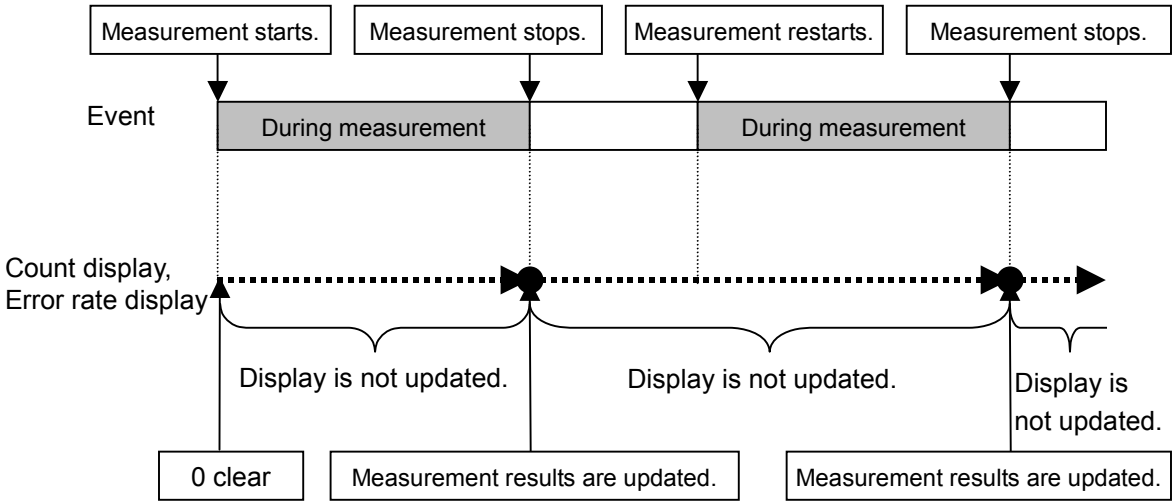

Figure 8.5-8 Measure Mode Continuous

Measure Mode: Single and Endless

The received bit count, error bit count, error rate are updated as needed during measurement. When the measurement is completed, the display update is stopped.

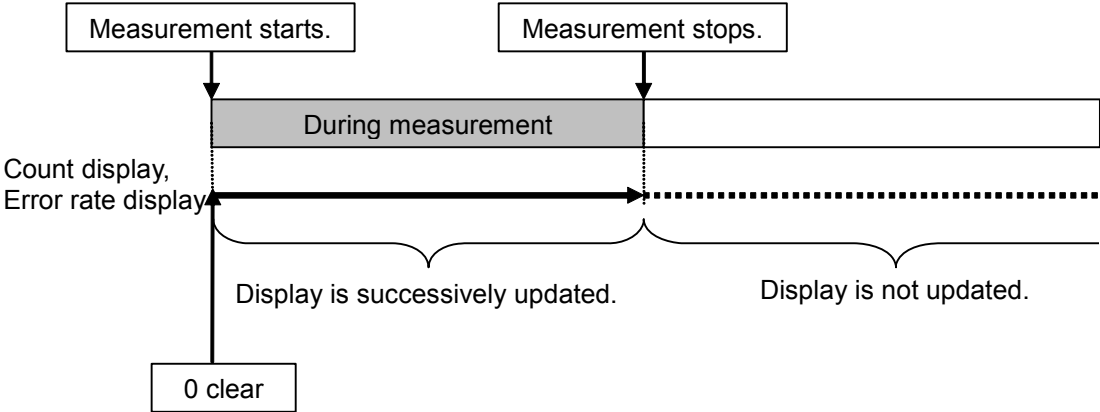



Figure 8.5-9 Measure Mode: Single and Endless

Note:

The measurement results may not be displayed correctly when “synchronizing” and “measuring” appear in the Status field alternately and repeatedly. In that case, check the settings and input signals and restart the measurement.

Count Clear operation

The operation when  (Count Clear) is pressed is described below. The Count Clear operation is disabled when Continuous is selected for the measurement mode.

During measurement (Synchronizing or Measuring):

The received bit count, error rate, and SyncLoss count are cleared during measurement while the synchronization state is held. Therefore, if Count Clear is executed during measurement, the received bit count at the end of measurement is smaller than the set measurement bit count. The same applies to the error bit count.

Example: Display when Count Clear is pressed when measuring 100000 bits

[1] Start the measurement.

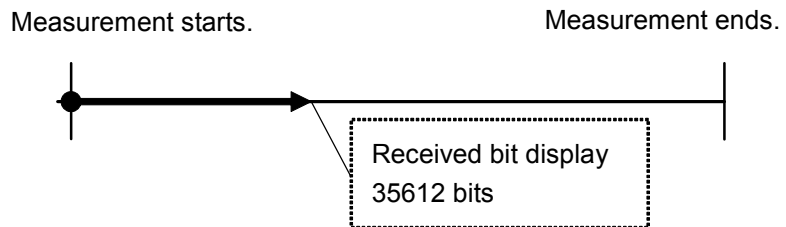

[2] Press Count Clear. The count bit count when the switch is pressed is 35612, however the display is 0 bits.

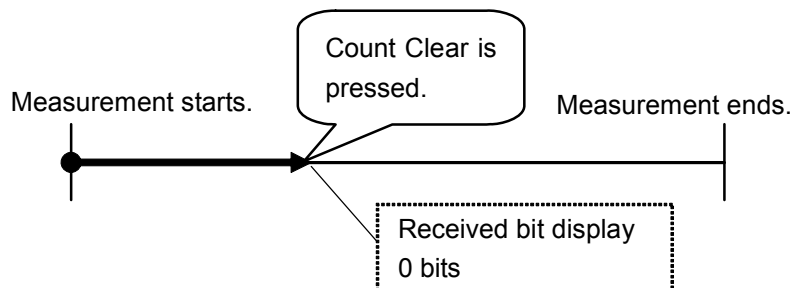

[3] The total count bit count is 100000 bits upon measurement completion, however the display is 64388 bits (100000 – 35612).

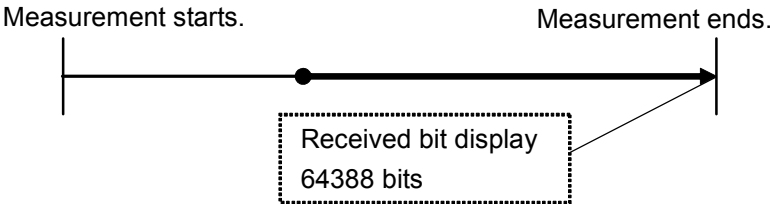

Figure 8.5-10 Count Clear operation

When measurement is stopped (Stop):
The received bit count, error rate, and progress state displays are cleared.

8.6 Setting Automatic Resynchronization Function

This section describes the settings for the automatic resynchronization function of BER measurement.

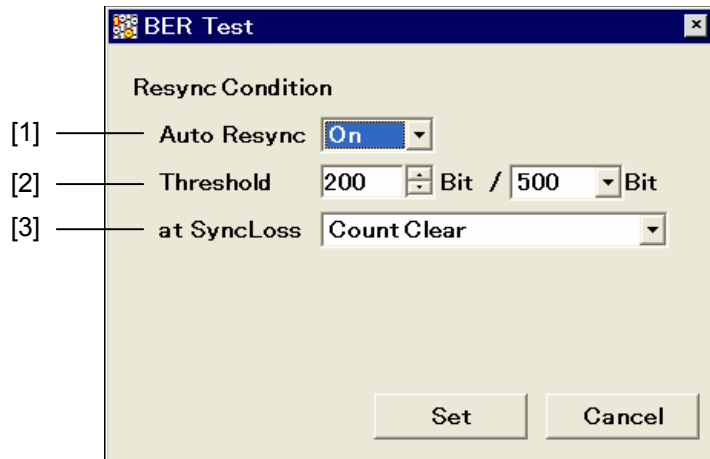

Figure 8.6-1 Resync Condition setup screen

Setting procedure for automatic resynchronization function

Press **F1** (Resync Condition) from page 2 of the main function menu to perform various settings for the automatic resynchronization function of BER measurement. Use the cursor to select the item to be set and press **F7** (Set) to display the setting window associated with that item.

The following items can be set in this menu.

[1] Auto Resync

Sets the resynchronization operation when SyncLoss occurs.

On SyncLoss is detected. Resynchronization is automatically performed when SyncLoss occurs.

Off SyncLoss is not detected.

The following items are enabled only when Auto Resync is set to On.

[2] Threshold

Sets the SyncLoss detection conditions. When X bits out of Y bits are errors, it is judged as SyncLoss. The values of X and Y can be set here.

Setting range of X (numerator): 1 to (Y/2) bits

Setting range of Y (denominator): 500, 5000, 50000 bits

Any value within the setting range can be set for X, while one of the three preset value should be set for Y.

[3] at SyncLoss	
	Sets whether to clear the measurement bit count when SyncLoss occurs.
Count Clear	Clears the measurement bit count to 0.
Count Keep	Retains the measurement bit count.

Details of Auto Resync

The difference in operation when Auto Resync is set to On and Off is described below.

Auto Resync On

If the number of occurred errors exceeds the set Threshold value when synchronization is established, it is judged as SyncLoss, the measurement is stopped, and resynchronization is executed. When Threshold is set to 200/500 (default) and the number of error bits out of 500 bits is 200 or less, measurement can be performed without SyncLoss being detected.

When measuring a signal with a high error rate, a high Threshold value, such as 200/500, can be set to suppress the detection of SyncLoss when block errors occur due to phasing.

When measuring a signal with a low error rate, a low Threshold setting, such as 50/500, can be set to enable resynchronization by quickly detecting SyncLoss when errors occur.

Auto Resync Off

SyncLoss is not detected during measurement. When a signal with a high error rate is measured, the measurement is performed without interruption with this setting. Note, however, that the clock and data may be out of synchronization when the clock is not regenerated on the DUT side. In such a case, set Auto Resync to On for measurement.

The correspondence between the error rate of the measurement target and the recommended setting is shown in the table below.



Table 8.6-1 Error rate of measurement target and recommended setting

Settings Error Rate of Measurement target	AutoResync On		AutoResync Off
	Threshold value: 50/500	Threshold value: 200/500	
Lower than 0.3%	Optimum	Applicable	Applicable
0.3% or Higher	Not recommended	Optimum	Applicable

Optimum: Most suitable setting
 Applicable: Measurement is possible with this setting.
 Not recommended: SyncLoss may occur frequently with this setting.

Reference:	
Default Threshold value of the MG3700A:	200/500
Threshold setting value of the MP1201C:	200/512
Default Threshold value of the MD6420A:	200/512
Threshold setting value of the MT8820A (WCDMA) BER function:	23/64

The differences between the Auto Resync operation supported in the MS2830A and the Auto Sync operation supported in the MP1201C and MD6420A are described below.

Details of Auto Resync operation

The details of the Auto Resync operation supported in the MS2830A are as follows.

Auto Resync On

Synchronization is executed at the start of measurement, and the measurement is started when synchronization is established. If SyncLoss is detected during measurement, resynchronization is automatically executed.

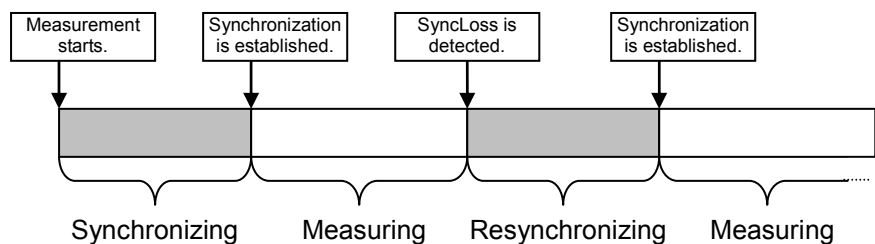

Figure 8.6-2 Auto Resync On

Auto Resync Off

Synchronization is executed at the start of measurement, and the measurement is started when synchronization is established. SyncLoss is not detected during measurement.

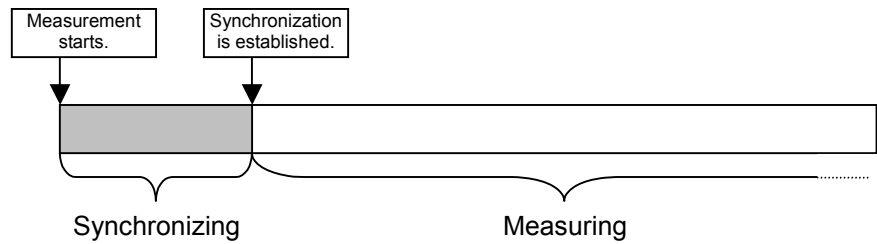

Figure 8.6-3 Auto Resync Off

Details of Auto Sync operation

The Auto Sync operation supported in the MP1201C and MD6420A is as follows.

Auto Sync On

Synchronization is executed at the start of measurement, and the measurement is started when synchronization is established. If SyncLoss is detected during measurement, resynchronization is automatically executed.

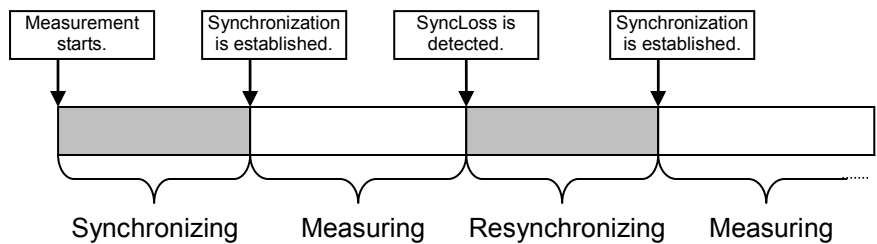

Figure 8.6-4 Auto Sync On



Auto Sync Off

Measurement is performed on the assumption that synchronization is established at the start of measurement. SyncLoss is not detected during measurement.

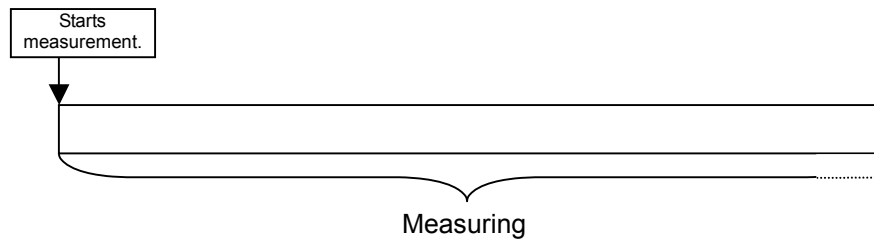

Figure 8.6-5 Auto Sync Off

Note:

To obtain a BER curve, set Auto Sync to On so as to establish synchronization with superior S/N, and then switch Auto Sync to Off to change S/N and start the measurement.

8.7 Setting Input Interface

This section describes the settings of the input interface used for BER measurement. BER measurement will not stop even if this setting is changed.

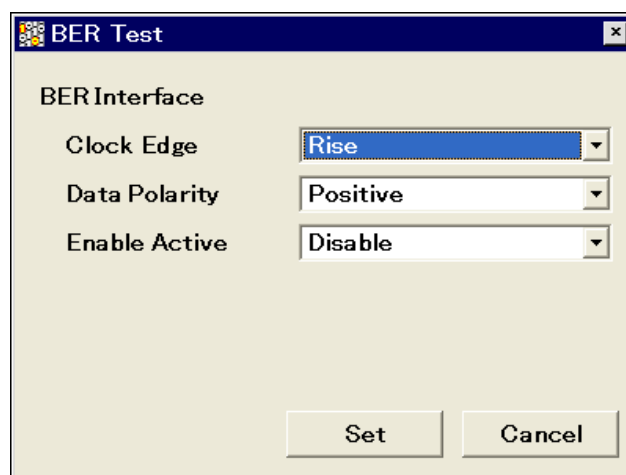

Figure 8.7-1 Input interface setup screen

Input interface setting procedure

Press **F2** (BER Interface) from page 2 of the main function menu to set the input interface to be used for BER measurement. Use the cursor to select the item to be set and press **F7** (Set) to display the setting window associated with that item. The settings for the input interface can be configured while continuing measurement.

The following items can be set in this menu.

- **Clock Edge (Rise/Fall)**
Switches the Clock signal detection edge between rising-edge detection and falling-edge detection.
- **Data Polarity (Positive/Negative)**
Switches the logic of the Data signal between positive and negative logic.
- **Enable Active (Disable/High/Low)**
Switches the logic of the Enable signal between unused, high active, and low active.

8.8 Setting PN_Fix Pattern

Special PN patterns called PN_Fix patterns can be used for BER measurement.

Details of PN_Fix pattern

A PN_Fix pattern consists of a repetitive part of a PN pattern and a PN pattern shorter than one period.

N repetitions of PN_x (N = 0, 1, 2, ...)

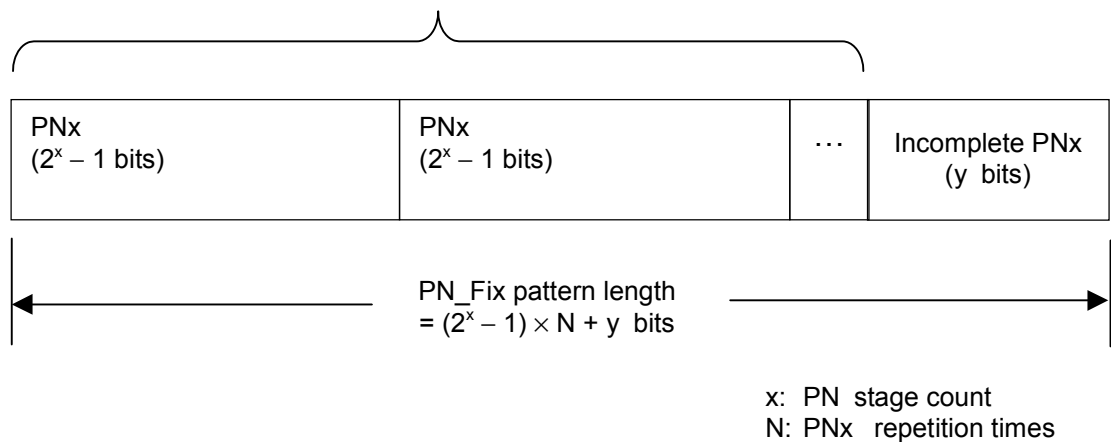

Figure 8.8-1 PN_Fix pattern

PN_Fix pattern setting procedure

To use a PN_Fix pattern, one of the following PN Fix patterns must be selected via Data Type selection.

PN9Fix, PN11Fix, PN15Fix, PN20Fix, PN23Fix

After the PN Type has been selected, press (PN_Fix Pattern) from page 2 of the main function menu to enable detailed settings for PN_Fix. Use the cursor to select the item to be set and set a value. The following items can be set in this menu.

[1] PN Pattern Initial

Sets the initial bit pattern of the PN_Fix pattern.

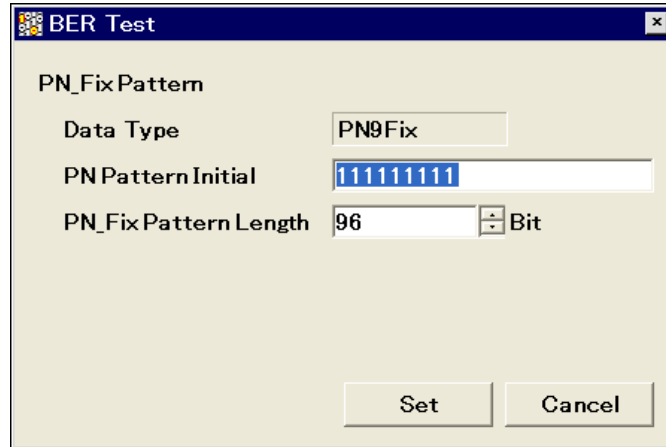

Figure 8.8-2 PN Pattern Initial setup screen

1. Enter the initial bit pattern of the PN_Fix pattern. Enter the initial bit pattern in binary. Use the numeric key pad (only 0 and 1) to enter numeric values.
2. The settable bit count varies depending on the selected PN type:

PN9Fix:	9 bits
PN11Fix:	11 bits
PN15Fix:	15 bits
PN20Fix:	20 bits
PN23Fix:	23 bits

[2] PN_Fix Pattern Length

Specifies the length of the entire PN_Fix pattern.

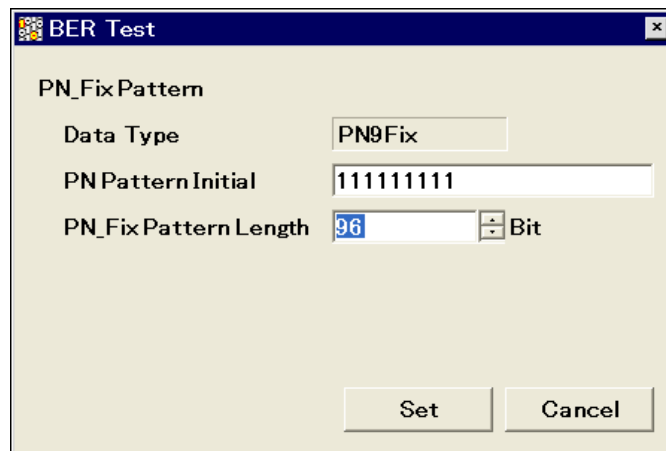

Figure 8.8-3 PN_Fix Pattern Length setup screen

Setting range: 96 to 134217728 bits

<Note on setting PN_Fix>

When the initial value of PN_Fix is set to All0, the following signals are output:

PN9, PN11, PN20: ALL0 signal

PN15, PN23: ALL1 signal

Synchronization establishing condition for PN_Fix patterns

The synchronization establishing conditions for the PN_Fix pattern are described below.

In the description below, x is assumed as “PN stage count” (x = 9 for PN9).

Synchronization establishment is performed in the following three steps:

- [1] Synchronization with the PN pattern is established if no error is detected for $(x \times 2)$ bits.
- [2] The last bit of the PNxFix pattern is detected from the set initial bit pattern length of the PN pattern.
- [3] Synchronization with the entire PN_Fix pattern is established if no error is detected for x bits beginning with the head of the PN_Fix pattern.

An example of synchronization establishment with the PN9Fix pattern is shown below.

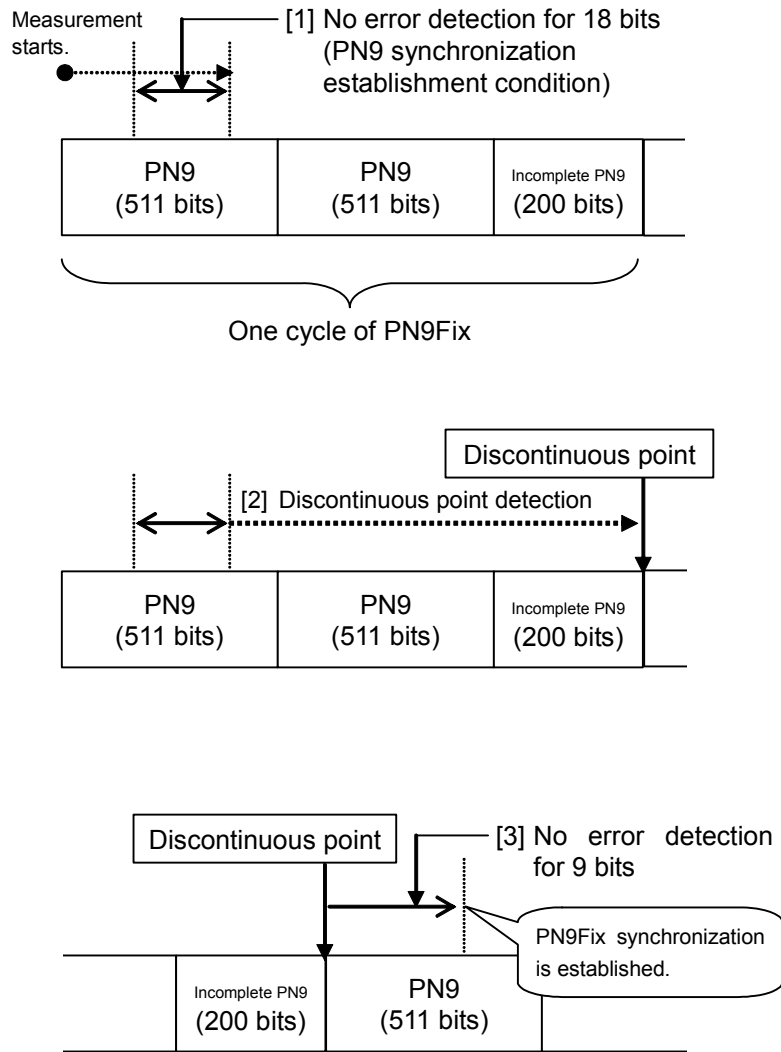

Figure 8.8-4 Example of synchronization establishment operation for PN9Fix pattern

PN_Fix pattern use example

A specific example of using a PN_Fix pattern is described below.

The following is described on the assumption that the frame format in a communication system is configured with fixed bits A (10 bits) and communication channels B (1000 bits) as shown in Figure 8.8-5 below.

If PN9 is used for the communication channel, the bit count per frame (1000 bits) does not match the PN9 period (511 bits). In this event, therefore, a period of 511 frames is required to retain the continuity of the PN9 signal of the communication channel.

In the case of a signal generator that uses an arbitrary waveform generator such as the MS2830A, however, the number of patterns that can be stored in the waveform memory may decrease or exceed the capacity of the waveform memory if the number of samples of the waveform pattern becomes larger due to an increase in the number of frames, as described above.

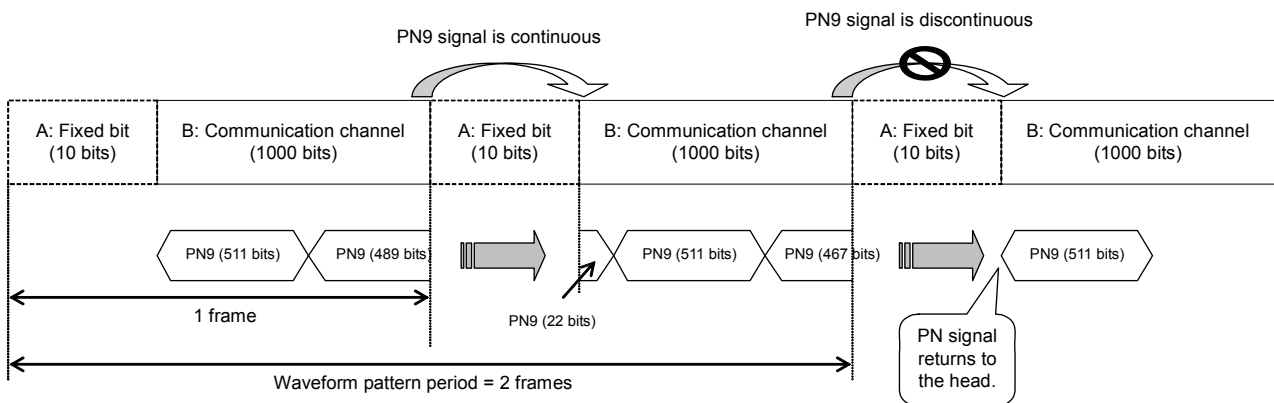

Figure 8.8-5 PN9Fix pattern example

In such a case, use a signal with a short period, such as a two-frame period signal generated by IQproducer™, and select “PNFix” for “Data Type” (see Figure 8.8-6 below). BER measurement can then be performed even for signals whose PN9 signal is discontinued in the middle of a frame, as shown in Figure 8.8-5 above.

Refer to the operation manual of each IQproducer™ for how to set the PN_Fix signal for the IQproducer™.

Note, however, that the random nature of a pseudo random signal may partially be lost during measurement using a PN_Fix signal.



Figure 8.8-6 BER measurement using PN_Fix data

8.9 Setting User-defined Pattern

The MS2830A-026/126 allows the use of patterns created by the user (user-defined patterns) for BER measurement.

Details of user-defined pattern files

User-defined patterns are arbitrary binary sequences with 8- to 4096-bit length.

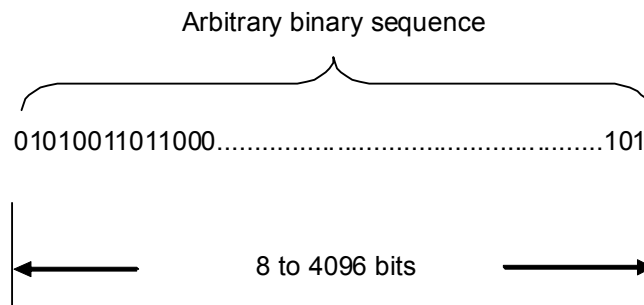

Figure 8.9-1 User-defined pattern

A user-defined pattern can be created in text file format using a PC. That file is then loaded from USB memory or the internal hard disk of the MS2830A. Create the file as described below and set the extension as “bpn.”

Table 8.9-1 shows the content that can be described in a user-defined pattern.

Table 8.9-1 Content that can be described in user-defined pattern

Character	Description
0, 1	Single-byte numbers. This portion is read as bit data. Numbers must be continuous using characters including spaces and line feeds.
Space	Single-byte space. These are used to make it easier to view bit data editing.
Line feed	CR/LF. This character is used to facilitate the view during bit data editing.
#	Single-byte sharp. Indicates comment lines.

The following shows examples of file content that can be loaded.

Example 1:

```
#20070216 Marked by Anritsu Co.  
0010 0111 0110 0011 0000 1111 0101
```

Example 2:

```
#UserPattern Start  
0000 0000 1111 1111  
#mark001  
0101 0101  
#mark002  
1111 1111 0000 0000
```

Displaying user-defined patterns

To use a user-defined pattern, select UserDefine for Data Type. The parameters for the loaded user-defined pattern will be displayed on the main screen. Blanks will be displayed if no user-defined pattern is loaded.

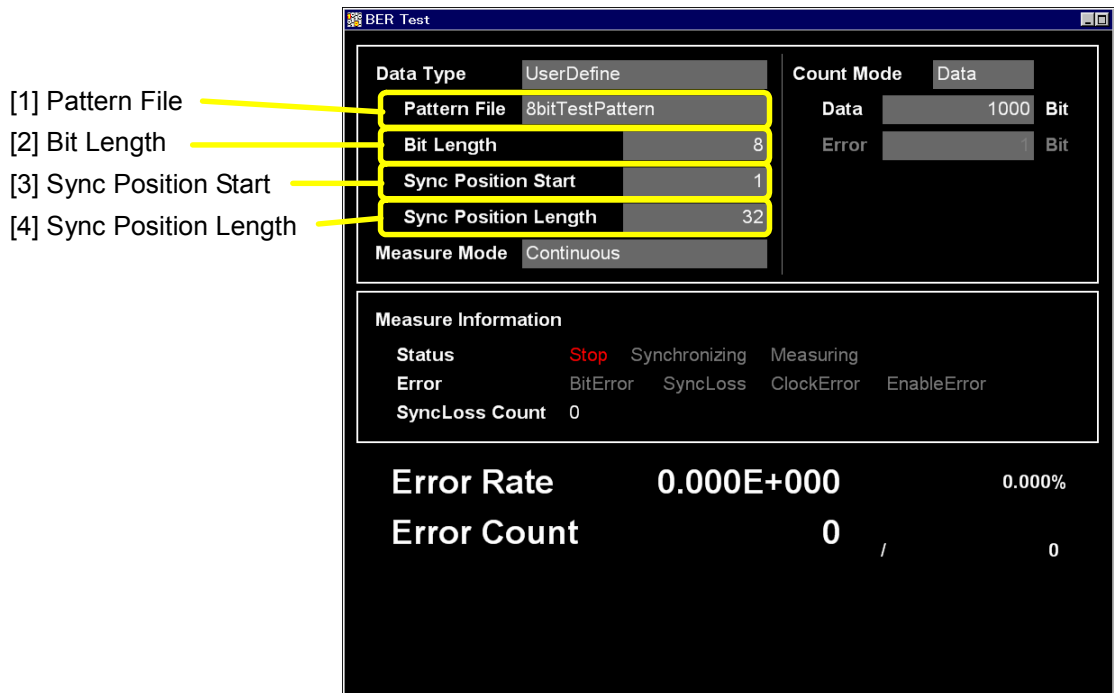

Figure 8.9-2 User-defined pattern parameter display

- [1] Pattern File
Displays the name of the loaded user pattern.
- [2] Bit Length
Displays the length (number of bits) of the loaded user pattern.
- [3] Sync Position Start
Displays the bit at which synchronizing the user pattern is to be started.
- [4] Sync Position Length
Displays a length (number of bits) to be compared with when synchronizing a user pattern.

User-defined pattern function menu

Select User Pattern for Data Type and press **F2** (User Defined Pattern) from page 2 of the main function menu to display the user-defined pattern file function menu.

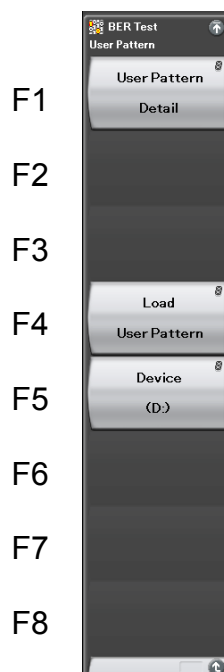

Figure 8.9-3 User-defined pattern function menu

Table 8.9-2 User-defined pattern function menu

Menu Display	Function
User Pattern Detail	Performs settings related for synchronizing loaded user-defined patterns.
Load User Pattern	Loads user-defined patterns from the USB memory or the internal hard disk of the MS2830A.
Device	Selects the media among the USB memory and internal hard disk from which user-defined patterns are to be loaded.

Procedure for loading User-defined patterns

This section describes the procedure for loading user-defined patterns.

<Procedure>

1. Press **F5** (Device) to select among the USB memory and internal hard disk, the device in which user-defined pattern files to be loaded are stored. Place user-defined pattern files in the root directory of the device.

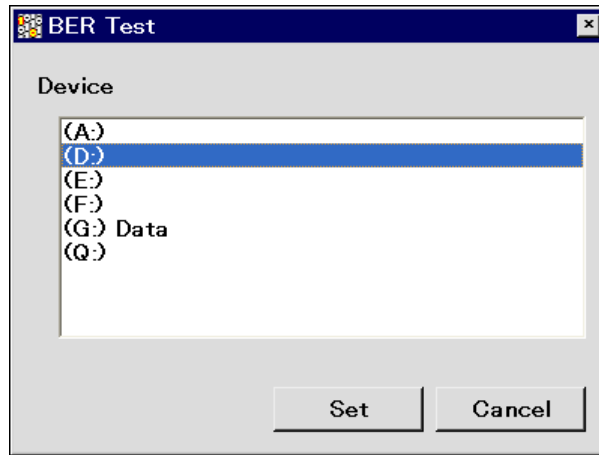

Figure 8.9-4 Device selection window

2. Press **F4** (Load User Pattern) to display the file selection window.

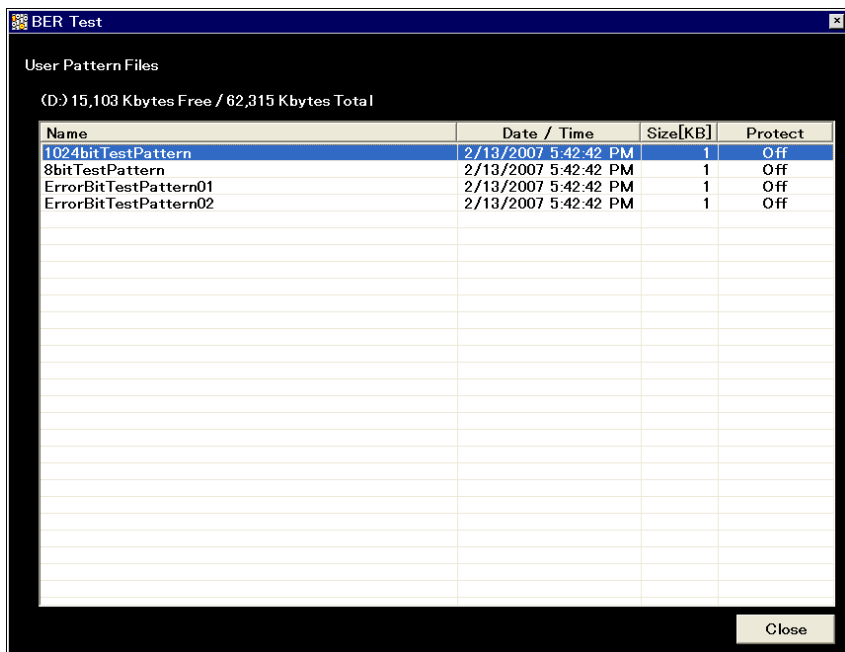





Figure 8.9-5 File selection window

3. Use the rotary knob or   to select the user-defined pattern file to be loaded.
4. Press  (Set) to load the selected user-defined pattern files.
If  (Cancel) is pressed, loading of the user-defined pattern file is cancelled and the file selection window is closed.

Only files with extension “.bpn” are displayed in the file selection window.

User-defined pattern files must be placed in the root directory of the USB memory or internal hard disk.

File names are displayed in ascending order for numbers and alphabetical characters.

Up to 100 files can be displayed in the file selection window. The 101st and subsequent files will not be displayed.

Up to 32 characters can be used for file names. Files with names consisting of 33 or more characters cannot be loaded.

If no user-defined pattern file exists in the media, the message “No file to read” will be displayed.

Either of the following messages will be displayed if the length of the user-defined pattern is out of the range supported by the MS2830A-026/126.

If shorter than 8 bits: “Bit pattern is too short.”

If longer than 4096 bits: “Bit pattern is too long.”

The error message “Illegal character exists.” will be displayed if the user-defined pattern file contains a character other than “0,” “1,” a line feed character, or “#.”

Synchronization establishing condition setting for user-defined patterns

When the user-defined pattern is loaded, set the conditions for synchronization establishment.

Set the start bit and the length of the section to be used for judging the synchronization establishment. If no error is detected in the specified part, it is judged that synchronization is established.

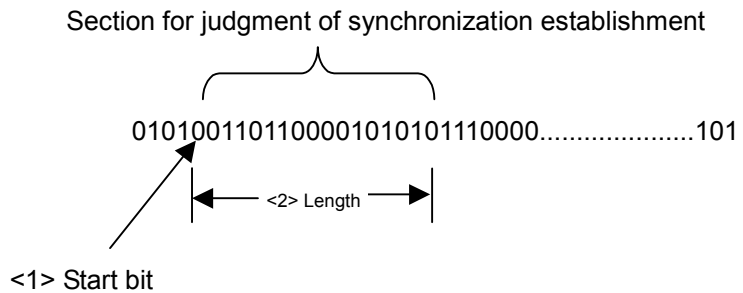

Figure 8.9-6 Setting method for section judged for synchronization establishment

Example: Setting synchronization for a user-defined pattern

<Procedure>

1. Press (User Pattern Detail) from the user-defined pattern function menu to display the User Pattern Detail setting window.

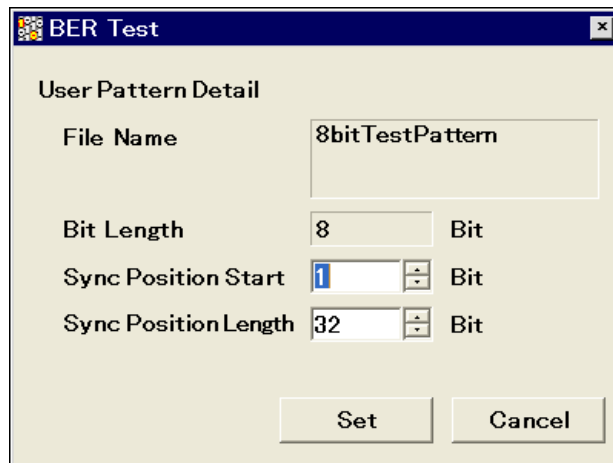



Figure 8.9-7 User pattern Detail setting window

2. Move the cursor to Sync Position Start and use the numeric key pad, rotary knob, or to set the start bit of the section judged for synchronization establishment.

Range: 1 to the length of the user-defined pattern

3. Move the cursor to Sync Position Length and use the numeric key pad, rotary knob, or   to set the length of the section judged for synchronization establishment.

Range: 8 to 1024

8.10 Description of BER Measurement Operation

This section describes the BER measurement operation, from synchronization to measurement termination.

When Auto Resync is set to Off

The following flowchart summarizes BER measurement operation when Auto Resync is set to Off. In this mode, the error rate is checked immediately after synchronization in order to judge whether synchronization is correctly established. If the error rate is 30% or higher, it is judged as a synchronization failure, and re-synchronization is executed.

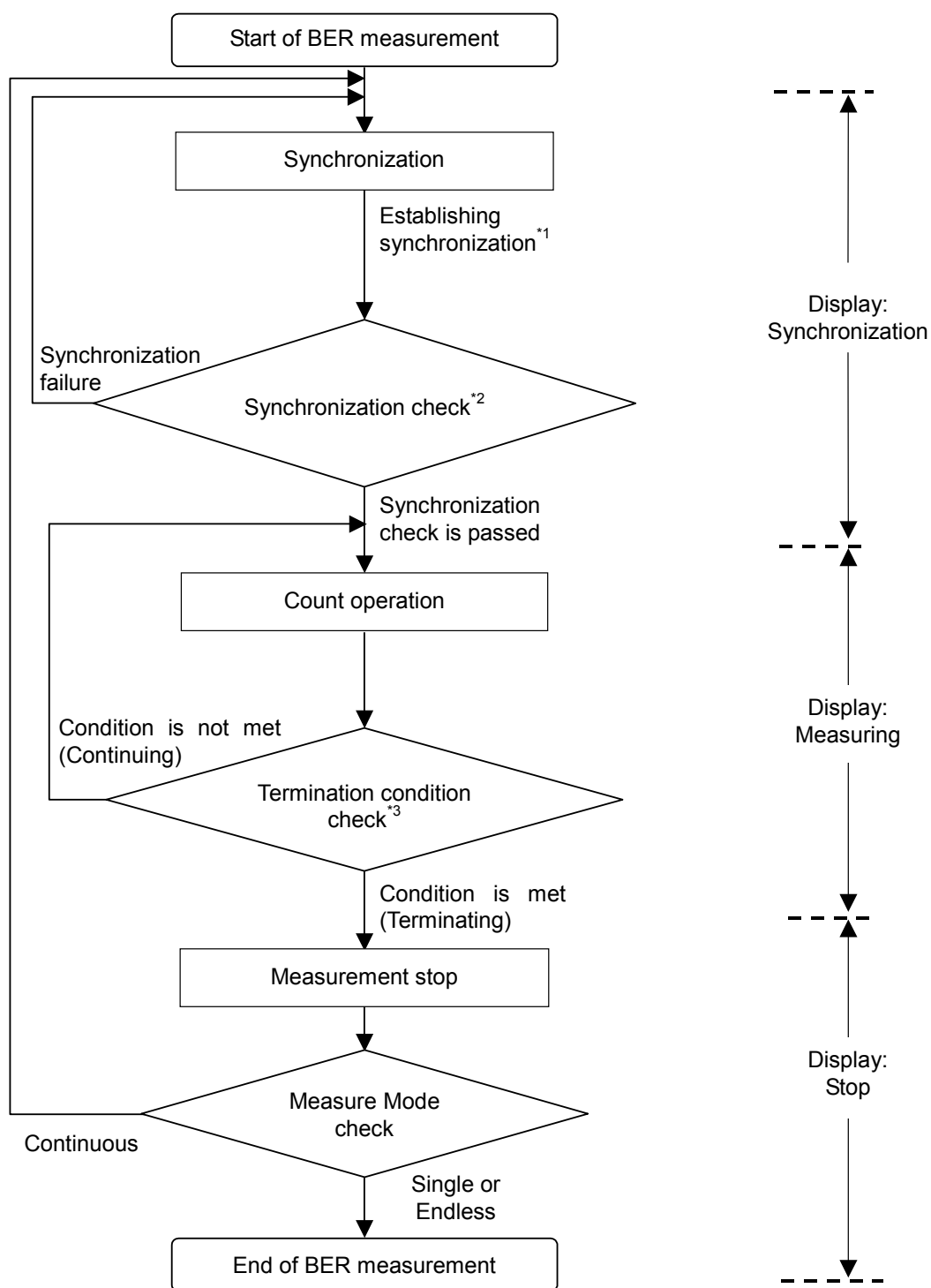

Figure 8.10-1 When Auto Resync is set to Off

- *1: The error rate is not checked if the measurement is terminated with a measurement bit count of less than 1000 bits. The measured values may be incorrect in this event.
- *2: If the error rate when the measurement bit count reaches 1000 bits is 30% or higher, it is judged as a synchronization failure.
- *3: The measurement termination conditions are as follows:
 - The accumulated measurement bit count or measurement error bit count reaches the set bit count.
 - The measurement bit count exceeds the maximum value.
 - The number of SyncLoss errors exceeds the maximum value.

8.10 Description of BER Measurement Operation

When Auto Resync is set to On

The following flowchart summarizes the BER measurement operation when Auto Resync is set to On. In this mode, resynchronization is automatically executed when SyncLoss occurs.

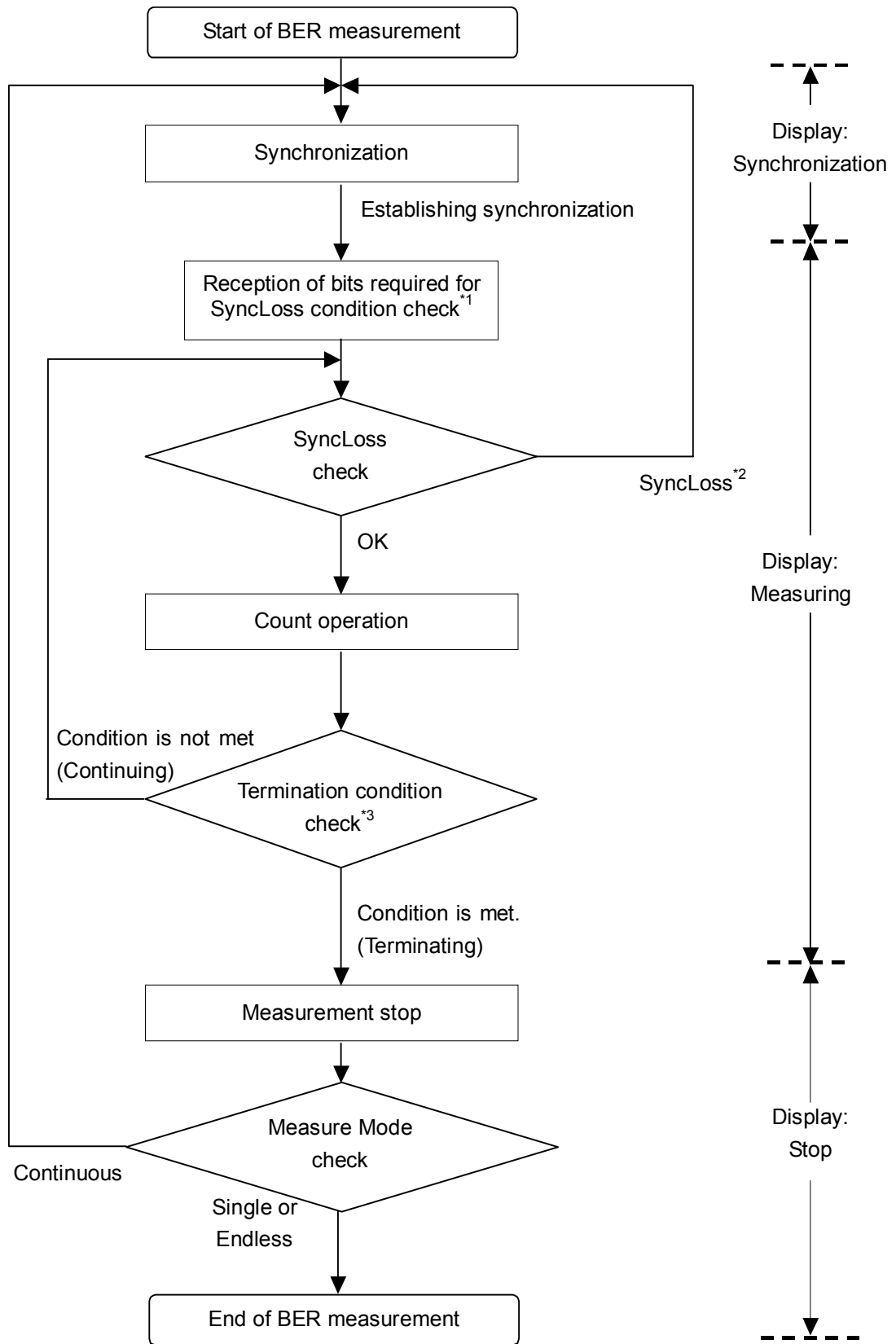

Figure 8.10-2 When Auto Resync is set to On

8.10 Description of BER Measurement Operation

- *1: The SyncLoss condition check is not executed until the number of received bits reaches the number of bits set as the denominator of the SyncLoss threshold set in [Threshold] on the Resync Condition Setup screen. Therefore, it may take some time to start the count operation after synchronization is established.
- *2: Operation after SyncLoss occurrence is performed according to the setting specified in “at SyncLoss” on the Resync Condition Setup screen.
- *3: The measurement termination conditions are as follows:
 - The accumulated measurement bit count or measurement error bit count reaches the set bit count.
 - The measurement bit count exceeds the maximum value.
 - The number of SyncLoss errors exceeds the maximum value.

Chapter 9 Maintenance

This chapter describes cautions related to daily maintenance, storage, and shipping of the MS2830A, as well as the calibration procedure to be used as preventive maintenance.

9.1	Daily Maintenance and Storage.....	9-2
9.1.1	Daily maintenance	9-2
9.1.2	Cautions on storage MS2830A for extended period.....	9-3
9.1.3	Storing USB memory.....	9-4
9.2	Repackaging and transporting when returning product.....	9-5
9.2.1	Repackaging.....	9-5
9.2.2	Transporting	9-5
9.3	Calibration.....	9-6
9.3.1	Calibration	9-6
9.3.2	Instruments used for calibrating MS2830A	9-6
9.3.3	Calibrating frequencies using oscilloscope	9-7

9.1 Daily Maintenance and Storage

9.1.1 Daily maintenance

Before daily maintenance of the MS2830A, be sure to turn the power off and unplug it from the AC outlet.

Panel surface dirt

When surface dirt is noticeable, after the MS2830A has been used in a dusty environment, or when the MS2830A has not been used for an extended period of time, wipe its surface with a cloth moistened in detergent and wrung enough.

Screen surface dirt

If the screen surface is dirty, first wipe it dry with a soft cloth. If the dirt persists, wipe the surface gently with a cloth dipped in detergent and wrung enough.

Loose screws

Use a Phillips screwdriver to tighten screws.

9.1.2 Cautions on storage MS2830A for extended period

Wipe off dust, fingerprint marks, stains, spots, etc. from the surface of the MS2830A before storing it. Avoid storing the MS2830A in these places:

- Places that are exposed to direct sunlight
- Dusty places
- Damp places where condensation may occur on the MS2830A surface
- Places where there the MS2830A may be corroded by active gases
- Places where the MS2830A may be oxidized
- Places having temperatures and relative humidity in the following ranges:

Temperature: -20°C or lower, or 60°C or higher

Humidity: 90% or higher

Recommended storage conditions

It is recommended that the MS2830A be stored in a place that meets the ambient conditions suggested above, plus the following conditions, if it is not to be used for a long period of time:

- Temperature: 5°C to 45°C
- Humidity: 40% to 80%
- Little temperature and humidity fluctuations within one day

9.1.3 Storing USB memory

Store the USB memory at temperatures between 4°C and 53°C and relative humidity between 8% and 90% (no condensation). Avoid storing the USB memory in places that are:

- Dusty or damp
- Close to magnetized items
- Exposed to direct sunlight
- Close to heat sources

9.2 Repackaging and transporting when returning product

The following describes cautions on transporting the MS2830A.

9.2.1 Repackaging

Repack the MS2830A in the packing material (box) in which it had been delivered. If the packing material has been scrapped or damaged, repack the MS2830A in the following manner:

1. Wrap the MS2830A in plastic or a similar material.
2. Procure a corrugated cardboard, wooden, or aluminum box large enough to pack in cushioning material around the MS2830A.
3. Place the MS2830A into the box. Then, pack in the cushioning material around the MS2830A so that the MS2830A does not move around in the box.
4. Secure the outside of the box with packaging cord, adhesive tape, bands, or other such implements.

9.2.2 Transporting

Avoiding as much vibrations as possible and satisfying the recommended storage conditions is recommended for transporting.

9.3 Calibration

9.3.1 Calibration

Perform calibration as preventive maintenance to keep the MS2830A's performance from becoming degraded. Even if the MS2830A is functioning normally, calibrate it periodically to maintain its performance.

Calibrating the MS2830A once or twice a year is recommended. If the MS2830A fails to meet specifications after calibration, contact an Anritsu Service and Sales office.

 **CAUTION**

Before performing the calibration, allow the MS2830A and the equipment used for the performance test to warm up at least 30 minutes to allow them to fully stabilize. For optimal measuring accuracy, run the MS2830A at the temperature of $23 \pm 5^{\circ}\text{C}$, with low AC voltage fluctuation (100 to 120 Vac or 200 to 240 Vac), in an environment free from noise, vibration, dust, moisture, and other harmful ambient conditions.

9.3.2 Instruments used for calibrating MS2830A

Table 9.3.2-1 lists the measuring instruments used to calibrate the MS2830A.

Table 9.3.2-1 List of measuring instruments for calibration

Name of Recommended Device	Required Performance	Calibration Items
Oscilloscope	Capable of 1 GHz measurement Supports external trigger input	Reference oscillator frequency accuracy
Signal generator	Capable of outputting 1 GHz signal (Resolution: 0.01 Hz or higher)	Reference oscillator frequency accuracy
Frequency standard device	Standard radio receiver or device with equivalent capability (Accuracy: 1×10^{-11} order or better)	Reference oscillator frequency accuracy

9.3.3 Calibrating frequencies using oscilloscope

Use an oscilloscope to calibrate the reference oscillator frequency. Use a frequency standard radio signal (signal synchronized with a standard radio signal or with a rubidium atom standard device) offering enough accuracy higher than the reference oscillator installed in the MS2830A.

Table 9.3.3-1 Calibration specifications

Reference Oscillator	Aging Rate	Temperature Stability
Internal reference oscillator	$\pm 1 \times 10^{-6}$ /year	$\pm 2.5 \times 10^{-6}$ (5 to 45°C)
High Stability Reference Oscillator*	$\pm 1 \times 10^{-7}$ /year	$\pm 2 \times 10^{-8}$ (5 to 45°C)

*: Only when a high Stability reference oscillator (optional) is installed.

Calibration procedure

The procedure for calibrating the frequency using an oscilloscope is described below.

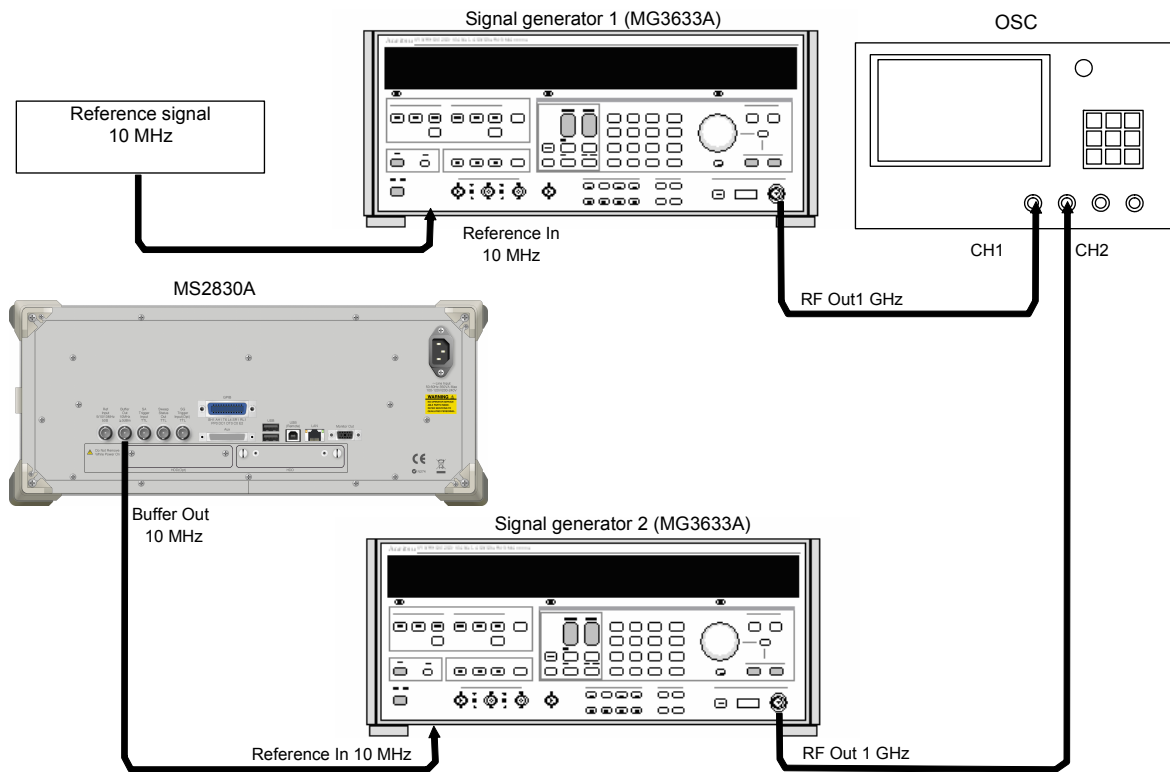

Figure 9.3.3-1 Connections for frequency calibration using oscilloscope

1. Connect a 10 MHz signal output from the frequency standard device to the reference signal input connector (Reference In) of signal generator 1.
2. Connect the reference signal output (Buffer Out) located on the rear panel of the MS2830A to the reference signal input connector (Reference In) of Signal Generator 2.
3. Connect the RF output connector of signal generator 1 to input connector CH1 of the oscilloscope and connect the RF output connector of signal generator 2 to input connector CH2 of the oscilloscope.
4. Set the frequency of signal generators 1 and 2 to 1 GHz for output.
5. Adjust the oscilloscope and set so that the input waveform of each signal generator can be observed.

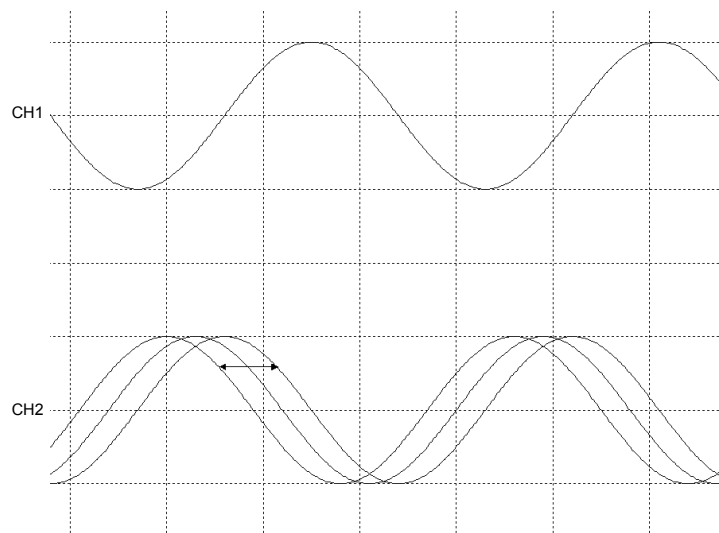

Figure 9.3.3-2 Oscilloscope waveform display

Set the trigger to the signal waveform of CH1 where the reference signal is output as shown in the figure above.

When the display waveform of signal generators 1 and 2 (CH1, CH2) input to the oscilloscope are stationary, it expresses that the frequency of the reference oscillator of the MS2830A and the reference frequency are synchronized, and normal values are acquired.

However, in the event synchronization is not achieved where the display waveform shifts to the right or left, adjust the reference oscillator of the MS2830A.

6. To achieve synchronization, start the Signal Analyzer or the Spectrum Analyzer application. Then press **F8** (Accessory) from the Main function menu of the signal analyzer or the spectrum analyzer.
7. Press **F6** (Reference Clock) from the Accessory function menu.
8. From the Reference Clock function menu, press **F1** (Reference Clock) then input adjustment values. The adjustment value can be set from 0 to 1023.
9. In practice, waveforms of the output frequency and reference frequency cannot be completely matched. Adjust so that phase fluctuations are as small as possible.
10. Perform adjustments, and when the output frequency of the MS2830A and the reference frequency match, the display waveform of the oscilloscope will be stationary.

Appendix A Performance Test Result Form

Performance Test Result Form

Test Location _____

Report No. _____
 Date _____
 Test person in charge _____

Equipment Name: MS2830A Signal Analyzer

Serial No. _____
 Power frequency _____

Ambient temperature _____ °C
 Relative humidity _____ %

Remarks _____

■ Reference Oscillator Frequency Stability

With MS2830A-040/041/043 installed (but without MS2830A-001/101, MS2830A-002/102)

Setting	Results	Frequency temperature stability	Frequency stability specification range
Frequency (at 23°C)			$\pm 2.5 \times 10^{-6}$ 5°C to 45°C (reference temperature = 23°C)
Frequency (at 45°C)			

Frequency temperature stability = [Frequency (at 45°C) – Frequency (at 23°C)]/Frequency (at 23°C)

Setting	Results	Frequency temperature stability	Frequency stability specification range
Frequency (at 23°C)			$\pm 2.5 \times 10^{-6}$ 5°C to 45°C (reference temperature = 23°C)
Frequency (at 5°C)			

Frequency temperature stability = [Frequency (at 5°C) – Frequency (at 23°C)]/Frequency (at 23°C)

Appendix A Performance Test Result Form

With MS2830A-044/045 installed (but without MS2830A-001/101)

Setting	Results	Frequency temperature stability	Frequency stability specification range
Frequency (at 23°C)			$\pm 2 \times 10^{-8}$ 5°C to 45°C (reference temperature = 23°C)
Frequency (at 45°C)			

Frequency temperature stability = [Frequency (at 45°C) – Frequency (at 23°C)]/Frequency (at 23°C)

Setting	Results	Frequency temperature stability	Frequency stability specification range
Frequency (at 23°C)			$\pm 2 \times 10^{-8}$ 5°C to 45°C (reference temperature = 23°C)
Frequency (at 5°C)			

Frequency temperature stability = [Frequency (at 5°C) – Frequency (at 23°C)]/Frequency (at 23°C)

■ Display Frequency Accuracy

MS2830A-040/041/043 display frequency accuracy test

Setting example			Minimum [Hz]	Result	Maximum [Hz]
Center freq [Hz]	Frequency span [Hz]	Resolution bandwidth [Hz]			
500 M	10 k	300	499999962		500000038
	200 k	3 k	499999428		500000572
	2 M	30 k	499994298		500005702
	5 M	30 k	499987998		500012002
	10 M	100 k	499973998		500026002
	20 M	100 k	499952998		500047002
	100 M	1 M	499739998		500260002
1800 M	10 k	300	179999962		180000038
	200 k	3 k	179999428		180000572
	2 M	30 k	179994298		180005702
	5 M	30 k	1799987998		1800012002
	10 M	100 k	1799973998		1800026002
	20 M	100 k	1799952998		1800047002
	3600 M	3 M	1792289998		1807710002

Display frequency accuracy test, only for MS2830A-041/043

Setting example			Minimum [Hz]	Result	Maximum [Hz]
Center freq [Hz]	Frequency span [Hz]	Resolution bandwidth [Hz]			
3000 M	10 k	300	299999962		300000038
	100 k	3 k	2999999638		3000000362
	2 M	30 k	2999994298		3000005702
	5 M	30 k	2999987998		3000012002
	10 M	100 k	2999973998		3000026002
	100 M	100 k	2999784998		3000215002
	6000 M	3 M	2987249998		3012750002

Appendix A Performance Test Result Form

Display frequency accuracy test, only for MS2830A-043

Setting example			Minimum [Hz]	Result	Maximum [Hz]
Center freq [Hz]	Frequency span [Hz]	Resolution bandwidth [Hz]			
6750M	10 k	300	6749999962		6750000038
	50 k	3 k	6749999743		6750000257
	2 M	30 k	6749994298		6750005702
	5 M	30 k	6749987998		6750012002
	10 M	100 k	6749973998		6750026002
	20 M	100 k	6749952998		6750047002
	13500M	3 M	6721499998		6778500002

Display frequency accuracy test, only for MS2830A-044/045

Setting example			Minimum [Hz]	Result	Maximum [Hz]
Center freq [Hz]	Frequency span [Hz]	Resolution bandwidth [Hz]			
500 M	10 k	300	499999962		500000038
	200 k	3 k	499999428		500000572
	2 M	30 k	499994298		500005702
	5 M	30 k	499987998		500012002
	10 M	100 k	499973998		500026002
	20 M	100 k	499952998		500047002
	100 M	1 M	499739998		500260002
2000 M	10 k	300	179999962		180000038
	200 k	3 k	179999428		180000572
	2 M	30 k	179994298		180005702
	5 M	30 k	1799987998		1800012002
	10 M	100 k	1799973998		1800026002
	20 M	100 k	1799952998		1800047002
	3600 M	3 M	1792289998		1807710002
7200	10k	300	719999962		720000038
	100k	3k	7199999638		7200000362
	2M	30k	7199994298		7200005702
	5M	30k	7199987998		7200012002
	10M	100k	7199973998		7200026002
	100M	100k	7199784998		7200215002
	4000M	3M	7191449998		7208550002
14450	10k	300	1444999960		1445000040
	50k	3k	14449999741		14450000259
	2M	30k	14449994296		14450005704
	5M	30k	14449987996		14450012004
	10M	100k	14449973996		14450026004
	20M	100k	14449952996		14450047004
	7900M	3M	14433259996		14466740004

Appendix A Performance Test Result Form

Display frequency accuracy test, only for MS2830A-044

Setting example			Minimum [Hz]	Result	Maximum [Hz]
Center freq [Hz]	Frequency span [Hz]	Resolution bandwidth [Hz]			
22450	10k	300	22449999956		22449999956
	200k	3k	22449999422		22449999422
	2M	30k	22449994292		22449994292
	5M	30k	22449987992		22449987992
	10M	100k	22449973992		22449973992
	20M	100k	22449952992		22449952992
	8100M	1M	22432839992		22432839992
13250	10k	300	13249999960		13250000040
	200k	3k	13249999426		13250000574
	2M	30k	13249994296		13250005704
	5M	30k	13249987996		13250012004
	10M	100k	13249973996		13250026004
	20M	100k	13249952996		13250047004
	26500M	3M	13194199996		13305800004

Display frequency accuracy test, only for MS2830A-045

Setting example			Minimum [Hz]	Result	Maximum [Hz]
Center freq [Hz]	Frequency span [Hz]	Resolution bandwidth [Hz]			
30150	10k	300	30149999956		30150000044
	100k	3k	30149999632		30150000368
	2M	30k	30149994292		30150005708
	5M	30k	30149987992		30150012008
	10M	100k	30149973992		30150026008
	100M	100k	30149784992		30150215008
	23500M	3M	30100499992		30199500008
21500	10k	300	21499999956		21500000044
	100k	3k	21499999632		21500000368
	2M	30k	21499994292		21500005708
	5M	30k	21499987992		21500012008
	10M	100k	21499973992		21500026008
	100M	100k	21499784992		21500215008
	43000M	3M	21409549992		21590450008

■ Frequency Span Display Accuracy

MS2830A-040/041/043 frequency span display accuracy test

Settings for MS2830A					Min [%]	Measurement Results $(f2' - f1') / 0.8 / \text{SPAN} \times 100 - 100$ [%]	Max [%]
Center Freq [Hz]	RBW [Hz]	Frequency Span [Hz]	Signal Generator				
			f1 [Hz]	f2 [Hz]			
1800 M	300	10 k	1799996000	1800004000	-0.2		+0.2
	30 k	1 M	1799600000	1800400000	-0.2		+0.2
	100 k	10 M	1796000000	1804000000	-0.2		+0.2
	1 M	100 M	1760000000	1840000000	-0.2		+0.2
	3 M	3600 M	3600000000	3240000000	-0.2		+0.2
3000M (MS2830A-041/043 only)	300	10 k	2999996000	3000004000	-0.2		+0.2
	30 k	1 M	2999600000	3000400000	-0.2		+0.2
	100 k	10 M	2996000000	3004000000	-0.2		+0.2
	1 M	100 M	2960000000	3040000000	-0.2		+0.2
	3 M	6000 M	6000000000	5400000000	-0.2		+0.2
6750M (MS2830A-043 only)	3 M	13500 M	13500000000	12150000000	-0.2		+0.2

Appendix A Performance Test Result Form

MS2830A-044/045 frequency span display accuracy test

Settings for MS2830A					Min [%]	Measurement Results	Max [%]
Center Freq [Hz]	RBW [Hz]	Frequency Span [Hz]	Signal Generator			$(f2' - f1') / 0.8 / \text{SPAN} \times 100 - 100$ [%]	
			f1 [Hz]	f2 [Hz]			
2000 M	300	10 k	1999996000	2000004000	-0.2		+0.2
	30 k	2 M	1999200000	2000800000	-0.2		+0.2
	100 k	30 M	1988000000	2012000000	-0.2		+0.2
	1 M	400 M	1840000000	2160000000	-0.2		+0.2
	3 M	4000 M	400000000	3600000000	-0.2		+0.2
7200 M	300	10 k	7199996000	7200004000	-0.2		+0.2
	30 k	2 M	7199200000	7200800000	-0.2		+0.2
	100 k	30 M	7188000000	7212000000	-0.2		+0.2
	1 M	400 M	7040000000	7360000000	-0.2		+0.2
	3 M	6600 M	4560000000	9840000000	-0.2		+0.2
14450 M	300	10k	14449996000	14450004000	-0.2		+0.2
	30k	2M	14449200000	14450800000	-0.2		+0.2
	100k	30M	14438000000	14462000000	-0.2		+0.2
	1M	400M	14290000000	14610000000	-0.2		+0.2
	3M	7900M	11290000000	17610000000	-0.2		+0.2
MS2830A-044 only							
22450M	300	10k	22449996000	22450004000	-0.2		+0.2
	30k	2M	22449200000	22450800000	-0.2		+0.2
	100k	30M	22438000000	22462000000	-0.2		+0.2
	1M	400M	22290000000	22610000000	-0.2		+0.2
	3M	8100M	19210000000	25690000000	-0.2		+0.2
13250M	3M	26500M	2900000000	2410000000	-0.2		+0.2
MS2830A-045 only							
30150M	300	10k	30149996000	30150004000	-0.2		+0.2
	30k	2M	30149200000	30150800000	-0.2		+0.2
	100k	30M	30138000000	30162000000	-0.2		+0.2
	1M	400M	29990000000	30310000000	-0.2		+0.2
	3M	23500M	26910000000	33390000000	-0.2		+0.2
21500M	3M	43000M	4300000000	38700000000	-0.2		+0.2

■ Single Sideband Noise Level

Settings for MS2830A			Result	Maximum [dBc/Hz]	Uncertainty [dB]
Offset frequency [Hz]	Center freq [Hz]	Resolution bandwidth [Hz]			
100 k	500.1 M	10 k		-115	+0.5
1 M	501 M	30 k		-133	+0.5

■ RF Frequency Characteristics

Frequency Band Mode: Normal (MS2830A-040/041/043 only)
 Without MS2830A-008/108 or with Preamplifier turned off:

Freq. [Hz]	Calibration value [dBm]	Measured value [dBm]	Minimum [dB]	Result	Maximum [dB]	Uncertainty [dB]
				Measured value – Calibration value [dB]		
10 M			-0.35		+0.35	±0.11
20 M			-0.35		+0.35	±0.11
50 M			-0.35		+0.35	±0.11
100 M			-0.35		+0.35	±0.11
200 M			-0.35		+0.35	±0.11
500 M			-0.35		+0.35	±0.11
1 G			-0.35		+0.35	±0.11
2 G			-0.35		+0.35	±0.11
3 G			-0.35		+0.35	±0.11

Frequency Band Mode: Normal (MS2830A-041/043 only)
 Without MS2830A-008/108 or with Preamplifier turned off:

4 G			-1.5		+1.5	±0.3
5 G			-1.5		+1.5	±0.3
6 G			-1.5		+1.5	±0.3

Frequency Band Mode: Normal (MS2830A-043 only)
 Without MS2830A-008/108 or with Preamplifier turned off:

6.01 G			-1.5		+1.5	±0.3
8 G			-1.5		+1.5	±0.3
10 G			-1.5		+1.5	±0.3
12 G			-1.5		+1.5	±0.3
13.5 G			-1.5		+1.5	±0.3

Appendix A Performance Test Result Form

Frequency Band Mode: Normal (MS2830A-040/041/043 only)

With MS2830A-008/108 and Preamplifier turned on:

Freq. [Hz]	Calibration value [dBm]	Measured value [dBm]	Minimum [dB]	Result	Maximum [dB]	Uncertainty [dB]
				Measured value – Calibration value [dB]		
50 M			-0.65		+0.65	±0.15
100 M			-0.65		+0.65	±0.15
200 M			-0.65		+0.65	±0.15
500 M			-0.65		+0.65	±0.15
1 G			-0.65		+0.65	±0.15
2 G			-0.65		+0.65	±0.15
3 G			-0.65		+0.65	±0.15

Frequency Band Mode: Normal (MS2830A-041/043 only)

With MS2830A-008/108 and Preamplifier turned on:

4 G			-1.8		+1.8	±0.15
5 G			-1.8		+1.8	±0.15
6 G			-1.8		+1.8	±0.15

Appendix A Performance Test Result Form

Frequency Band Mode: Normal (MS2830A-044/045 only)
 With MS2830A-008/108 and Preamplifier turned on:

Freq. [Hz]	Calibration value [dBm]	Measured value [dBm]	Minimum [dB]	Result	Maximum [dB]	Uncertainty [dB]
				Measured value – Calibration value [dB]		
10 M			-0.65		+0.65	±0.15
20 M			-0.65		+0.65	±0.15
50 M			-0.65		+0.65	±0.15
100 M			-0.65		+0.65	±0.15
200 M			-0.65		+0.65	±0.15
500 M			-0.65		+0.65	±0.15
1 G			-0.65		+0.65	±0.15
2 G			-0.65		+0.65	±0.15
3 G			-0.65		+0.65	±0.15
4 G			-1.8		+1.8	±0.15
5 G			-1.8		+1.8	±0.15
6 G			-1.8		+1.8	±0.15

Appendix A Performance Test Result Form

Frequency Band Mode: Normal (MS2830A-044/045 only)

With MS2830A-068/168 and Preamplifier turned on:

Without MS2830A-067/167, with Microwave Preselector Bypass turned off and after Preselector Auto Tune is done:

Freq. [Hz]	Calibration value [dBm]	Measured value [dBm]	Minimum [dB]	Result	Maximum [dB]	Uncertainty [dB]
				Measured value – Calibration value [dB]		
10 M			-0.65		+0.65	±0.15
20 M			-0.65		+0.65	±0.15
50 M			-0.65		+0.65	±0.15
100 M			-0.65		+0.65	±0.15
200 M			-0.65		+0.65	±0.15
500 M			-0.65		+0.65	±0.15
1 G			-0.65		+0.65	±0.15
2 G			-0.65		+0.65	±0.15
3 G			-0.65		+0.65	±0.15
4 G			-1.8		+1.8	±0.3
5 G			-1.8		+1.8	±0.3
6 G			-1.8		+1.8	±0.3
6.01 G			-1.8		+1.8	±0.3
8 G			-1.8		+1.8	±0.3
10 G			-1.8		+1.8	±0.3
12 G			-1.8		+1.8	±0.3
13.5 G			-1.8		+1.8	±0.3
15 G			-2.5		+2.5	±0.6
17 G			-2.5		+2.5	±0.6
20 G			-2.5		+2.5	±0.6
26.5 G			-2.5		+2.5	±0.6

Frequency Band Mode: Normal (MS2830A-045 only)

Without MS2830A-008/108/068/168 or with Preamplifier turned off:

Without MS2830A-067/167, with Microwave Preselector Bypass turned off and after Preselector Auto Tune is done:

29 G			-3.0		+3.0	±0.8
33 G			-3.0		+3.0	±0.8
40 G			-3.0		+3.0	±0.8

Appendix A Performance Test Result Form

Frequency Band Mode: Normal (MS2830A-044/045 only)

Without MS2830A-008/108/068/168 or with Preamplifier turned off:

Without MS2830A-067/167, with Microwave Preselector Bypass turned off and after Preselector Auto Tune is done:

Freq. [Hz]	Calibration value [dBm]	Measured value [dBm]	Minimum [dB]	Result	Maximum [dB]	Uncertainty [dB]
				Measured value – Calibration value [dB]		
10 M			-0.35		+0.35	±0.11
20 M			-0.35		+0.35	±0.11
50 M			-0.35		+0.35	±0.11
100 M			-0.35		+0.35	±0.11
200 M			-0.35		+0.35	±0.11
500 M			-0.35		+0.35	±0.11
1 G			-0.35		+0.35	±0.11
2 G			-0.35		+0.35	±0.11
3 G			-0.35		+0.35	±0.11
4 G			-1.5		+1.5	±0.3
5 G			-1.5		+1.5	±0.3
6 G			-1.5		+1.5	±0.3
6.01 G			-1.5		+1.5	±0.3
8 G			-1.5		+1.5	±0.3
10 G			-1.5		+1.5	±0.3
12 G			-1.5		+1.5	±0.3
13.5 G			-1.5		+1.5	±0.3
15 G			-2.5		+2.5	±0.7
17 G			-2.5		+2.5	±0.7
20 G			-2.5		+2.5	±0.7
26.5 G			-2.5		+2.5	±0.7

Frequency Band Mode: Normal (MS2830A-045 only)

Without MS2830A-008/108/068/168 or with Preamplifier turned off:

Without MS2830A-067/167, with Microwave Preselector Bypass turned off and after Preselector Auto Tune is done:

29 G			-2.5		+2.5	±0.8
33 G			-2.5		+2.5	±0.8
40 G			-2.5		+2.5	±0.8

■ Display Average Noise Level

Frequency Band Mode: Normal (MS2830A-040/041/043 only)

Without MS2830A-062/066 installed and without MS2830A-008/108 installed, or with Preamplifier turned off:

Center freq [Hz]	Display Average Noise Level [dBm/Hz]	Maximum [dBm/Hz]
100 k		-134
1 M		-144
30 M		-153
99 M		
999 M		
1999 M		-151
2399 M		
2999 M		-149
3999 M		-146
4999 M		
5999 M		
6001 M		-142
8001 M		
9999 M		
11499 M		-142
13499 M		

Frequency Band Mode: Normal (MS2830A-040/041/043 only)

Without MS2830A-062/066, and with MS2830A-008/108, or with Preamplifier turned on:

Center freq [Hz]	Display average noise level [dBm/Hz]	Maximum [dBm/Hz]
1 M		-156
30 M		-163
99 M		
999 M		
1999 M		-162
2399 M		-160
2999 M		
3999 M		-157
4999 M		-157
6000 M		

Note:

MS2830A-040: 100 kHz to 3600 MHz

MS2830A-041: 100 kHz to 6000 MHz

MS2830A-043: 100 kHz to 13500 MHz

Appendix A Performance Test Result Form

Frequency Band Mode: Normal (MS2830A-040/041/043 only)

Without MS2830A-062/066 installed, and without MS2830A-008/108 installed, or with Preamplifier turned off:

Center freq [Hz]	Display average noise level [dBm/Hz]	Maximum [dBm/Hz]
100 k		-133
1 M		-143
30 M		-152
99 M		
999 M		
1999 M		-150
2399 M		-147
2999 M		
3999 M		
4999 M		-144
5999 M		-142
6001 M		
8001 M		
9999 M		-142
11499 M		
13499 M		

Frequency Band Mode: Normal (MS2830A-040/041/043 only)

With MS2830A-062/066, and with MS2830A-008/108, or with Preamplifier turned on:

Center freq [Hz]	Display average noise level [dBm/Hz]	Maximum [dBm/Hz]
1 M		-155
30 M		-162
99 M		
999 M		
1999 M		-161
2399 M		-158
2999 M		
3999 M		
4999 M		-154
6000 M		-154

Note:

MS2830A-040: 100 kHz to 3600 MHz

MS2830A-041: 100 kHz to 6000 MHz

MS2830A-043: 100 kHz to 13500 MHz

Appendix A Performance Test Result Form

Frequency Band Mode: Normal (MS2830A-044/045 only)
 Without MS2830A-067/167/068/168,

Center freq [Hz]	Display average noise level [dBm/Hz]	Maximum [dBm/Hz]
100 k		-134
1 M		-144
30 M		-153
99 M		
999 M		
1999 M		-151
2399 M		
2999 M		-149
3999 M		-146
4999 M		-149
5999 M		
6001 M		-151
8001 M		
9999 M		
11499 M		
13499 M		
18399 M		-149
26499 M		-145
39999 M		-146
42999 M		-142

Note:

MS2830A-044: 100 kHz to 26500 MHz

MS2830A-045: 100 kHz to 43000 MHz

Appendix A Performance Test Result Form

Frequency Band Mode: Normal (MS2830A-044/045 only)

Without MS2830A-067/167, and with MS2830A-068/168, or with Preamplifier turned off:

Center freq [Hz]	Display average noise level [dBm/Hz]	Maximum [dBm/Hz]
100 k		-134
1 M		-144
30 M		-153
99 M		
999 M		
1999 M		-151
2399 M		-149
2999 M		
3999 M		
4999 M		-146
5999 M		-147
6001 M		
8001 M		
9999 M		
11499 M		
13499 M		-145
18399 M		-141
26499 M		-139
39999 M		-135
42999 M		

Note:

MS2830A-044: 100 kHz to 26500 MHz

MS2830A-045: 100 kHz to 43000 MHz

Appendix A Performance Test Result Form

Frequency Band Mode: Normal (MS2830A-044/045 only)

Without MS2830A-067/167, and with MS2830A-068/168, or with Preamplifier turned on:

Center freq [Hz]	Display average noise level [dBm/Hz]	Maximum [dBm/Hz]
1 M		-156
30 M		
99 M		-163
999 M		
1999 M		-162
2399 M		
2999 M		-160
3999 M		-157
4999 M		
5999 M		-157
6001 M		
8001 M		
9999 M		-160
11499 M		
13499 M		
18399 M		-158
26499 M		-156
39999 M		-156
42999 M		-154

Note:

MS2830A-044: 100 kHz to 26500 MHz

MS2830A-045: 100 kHz to 43000 MHz

Frequency Band Mode: Normal (MS2830A-044/045 only)
 With MS2830A-067/167 and without MS2830A-068/168,

Center freq [Hz]	Display average noise level [dBm/Hz]	Maximum [dBm/Hz]
6001 M		-147
8001 M		
9999 M		
11499 M		
13499 M		
18399 M		-145
26499 M		-141
39999 M		-135
42999 M		-132

Note:

MS2830A-044: 100 kHz to 26500 MHz

MS2830A-045: 100 kHz to 43000 MHz

Frequency Band Mode: Normal (MS2830A-044/045 only)
 With MS2830A-067/167, and with MS2830A-068/168, or with Preamplifier turned off:

Center freq [Hz]	Display average noise level [dBm/Hz]	Maximum [dBm/Hz]
6001 M		-143
8001 M		
9999 M		
11499 M		
13499 M		
18399 M		-141
26499 M		-137
39999 M		-131
42999 M		-128

Note:

MS2830A-044: 100 kHz to 26500 MHz

MS2830A-045: 100 kHz to 43000 MHz

Appendix A Performance Test Result Form

Frequency Band Mode: Normal (MS2830A-044/045 only)

With MS2830A-067/167, and with MS2830A-068/168, or with Preamplifier turned on:

Center freq [Hz]	Display average noise level [dBm/Hz]	Maximum [dBm/Hz]
6001 M		-154
8001 M		
9999 M		
11499 M		
13499 M		
18399 M		-152
26499 M		-150
39999 M		-144
42999 M		-141

Note:

MS2830A-044: 100 kHz to 26500 MHz

MS2830A-045: 100 kHz to 43000 MHz

■ Second Harmonic Wave Distortion

MS2830A-040/041/043

Without MS2830A-008/108, or with Preamplifier turned off:

Settings for MS2830A				Result [dBc]	Maximum [dBc] ()	Uncertainty [dB]
Freq. [MHz]	Ref_Level [dBm]	Output level [dBm]	Applicable LPF			
51	-30	-20	SLP-50+		(Mixer Input level=-30 dBm) -60	+1.5
401	-30	-20	VLF-400 (+)		(Mixer Input level=-30 dBm) -65	+1.5
1799	-30	-20	VLF-2250 (+) (2-stage series)			+1.5
2999	0	0	VLF-3000 (+) (2-stage series)		(Mixer Input level=-10 dBm) -70	+3.0
5999	0	0	VLF-6000 (+) (2-stage series)			+3.0

MS2830A-040/041/043

With MS2830A-008/108 and Preamplifier turned on:

Settings for MS2830A				Result [dBc]	Maximum [dBc]	Uncertainty [dB]
Freq. [MHz]	Ref_Level [dBm]	Output level [dBm]	Applicable LPF			
51	-35	-35	SLP-50+		(Preamp input level=-45 dBm) -50	+1.5
401	-35	-35	VLF-400 (+)		(Preamp input level=-45 dBm) -55	+1.5

Appendix A Performance Test Result Form

2999	-35	-35	VLF-3000 (+) (2-stage series)			+1.5
------	-----	-----	----------------------------------	--	--	------

MS2830A-044/04

Without MS2830A-008/108/068/168 and MS2830A-067/167:

Settings for MS2830A				Result [dBc]	Maximum [dBc] ()	Uncertainty [dB]
Freq. [MHz]	Ref_Level [dBm]	Output level [dBm]	Applicable LPF			
51	-30	-20	SLP-50+		(Mixer Input level=-30 dBm) -60	+1.5
401	-30	-20	VLF-400 (+)		(Mixer Input level=-30 dBm) -65	+1.5
1799	-30	-20	VLF-2250 (+) (2-stage series)			+1.5
2999	0	0	VLF-3000 (+) (2-stage series)		(Mixer Input level=-10 dBm) -70	+3.0
5999	0	0	VLF-6000 (+) (2-stage series)		(Mixer Input level=-10 dBm) -90	+3.0
6749	0	0	VLF-6700 (+) (2-stage series)			+3.0

Appendix A Performance Test Result Form

MS2830A-044/045

With MS2830A-068/168 or with Preamplifier turned off:

Or, with MS2830A-067/167 and Microwave Preselector Bypass turned off:

Settings for MS2830A				Result [dBc]	Maximum [dBc] ()	Uncer- tainty [dB]
Freq. [MHz]	Ref_Level [dBm]	Output level [dBm]	Applicable LPF			
51	-30	-20	SLP-50+		(Mixer Input level=-30 dBm) -60	+1.5
401	-30	-20	VLF-400 (+)		(Mixer Input level=-30 dBm) -65	+1.5
1799	-30	-20	VLF-2250 (+) (2-stage series)			+1.5
2999	0	0	VLF-3000 (+) (2-stage series)		(Mixer Input level=-10 dBm) -70	+3.0
5999	0	0	VLF-6000 (+) (2-stage series)			+3.0
6749	0	0	VLF-6700 (+) (2-stage series)			+3.0

Appendix A Performance Test Result Form

MS2830A-044/045

With MS2830A-008/108/068/168 or with Preamplifier turned on:

Settings for MS2830A				Result [dBc]	Maximum [dBc] ()	Uncer- tainty [dB]
Freq. [MHz]	Ref_Level [dBm]	Output level [dBm]	Applicable LPF			
51	-30	-20	SLP-50+		(Mixer Input level=-45 dBm) -50	+1.5
401	-30	-20	VLF-400 (+)		(Mixer Input level=-45 dBm) -55	+1.5
1799	-30	-20	VLF-2250 (+) (2-stage series)			+1.5
2999	-30	-20	VLF-3000 (+) (2-stage series)		(Mixer Input level=-45 dBm) -45	+3.0
5999	-30	-20	VLF-6000 (+) (2-stage series)			+3.0
6749	-30	-20	VLF-6700 (+) (2-stage series)			+3.0

Appendix B Panel Keys and Keyboard Operations

Table B-1 Correspondences between panel keys and keyboard operations





















Panel Key	USB Keyboard
 [Preset]	[Ctrl]+[Shift]+[R]
 [Top]	[Ctrl]+[Shift]+[↑]
 [F1]	[F1]
 [F2]	[F2]
 [F3]	[F3]
 [F4]	[F4]
 [F5]	[F5]
 [F6]	[F6]
 [F7]	[F7]
 [F8]	[F8]
 [Back]	[Ctrl]+[Shift]+[←]
 [More]	[Ctrl]+[Shift]+[→]
 [Trace]	[Ctrl]+[Alt]+[V]
 [Measure]	[Ctrl]+[Alt]+[X]
 Encoder [Right rotation]	Mouse wheel [Scroll for above]
 Encoder [Left rotation]	Mouse wheel [Scroll for below]
 [↑]	[↑]
 [→]	[→]
 [↓]	[↓]
 [←]	[←]
 [Enter]	[Enter]

Table B-1 Correspondences between panel keys and keyboard operations (Cont'd)

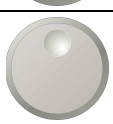































Panel Key	USB Keyboard
 [0]	[0]
 [1]	[1]
 [2]	[2]
 [3]	[3]
 [4]	[4]
 [5]	[5]
 [6]	[6]
 [7]	[7]
 [8]	[8]
 [9]	[9]
 [.]	[.]
 [+/-]	[-]
 [Shift]	[Shift]+
 [Cancel]	[Esc]
 [BS]	[Back Space]
 [Single]	[Ctrl]+[Shift]+[F1]
 [Continuous]	[Ctrl]+[Shift]+[F2]
 [Frequency]	[Ctrl]+[Shift]+[0]
 [Span]	[Ctrl]+[Shift]+[1]
 [Amplitude]	[Ctrl]+[Shift]+[2]
 [Marker]	[Ctrl]+[Shift]+[3]
 [BW]	[Ctrl]+[Shift]+[4]
 [Trigger/Gate]	[Ctrl]+[Shift]+[5]
 [Time/Sweep]	[Ctrl]+[Shift]+[6]
 [Peak Search]	[Ctrl]+[Shift]+[7]
 [Save]	[Ctrl]+[S]
 [Recall]	[Ctrl]+[O]
 [Copy]	[Ctrl]+[Shift]+ [8]
 [Cal]	[Ctrl]+[Shift]+[9]

Table B-1 Correspondences between panel keys and keyboard operations (Cont'd)

Panel Key	USB Keyboard
 [SPA]	Not available
 [SA]	Not available
 [SG]	Not available
 [Appli]	Not available











Note:

The figure in [Ctrl]+[Shift]+“figure” cannot be entered by the numeric keypad.

Appendix C Virus Check Procedure

For the MS2830A, we recommend not installing virus scanning software to ensure the best possible performance of the equipment. In some user operating environments, however, the equipment might not be completely protected from virus infection, and periodic virus scans might be required. This chapter provides a procedure to use to check for viruses and the related cautions.

The following shows an overview of the virus scanning procedure, in which the equipment drives are mounted (assigned) to network drives on an external computer, and then viruses are checked for using antivirus software installed in that computer.

C.1	Connecting External PC to MS2830A	C-3
		
C.2	Checking IP address of MS2830A.....	C-3
		
C.3	Configuring shared settings	C-4
		
C.4	Changing the user account for the equipment.....	C-5
		
C.5	Shared Settings for MS2830A	C-8
		
C.6	Mounting the equipment drives to the external computer drives	C-10
		
C.7	Scanning for virus	C-11
		
C.8	Unmounting the equipment drives from the external computer drives	C-11
		
C.9	Making the equipment drives unshared.....	C-11
		
C.10	Restoring the previous user account setting for the equipment	C-11
		
C.11	Enabling Simple File Sharing.....	C-12

Note:

1. Be sure to follow the procedure described in this document. If this procedure is not followed, not only will it not be possible to check for viruses, but the equipment might become unusable.

If the equipment runs abnormally after removing viruses, execute system recovery to restore all drives to the factory default settings. For the procedure, refer to “System Recovery Functions” in Chapter 5 of “MS2830A Signal Analyzer Operation Manual (Mainframe Operation)”.

After performing system recovery, the firmware might have to be upgraded to the latest version depending on when the equipment was released.

2. Before using antivirus software, be sure to check its usage and the license scope.

C.1 Connecting External PC to MS2830A

Connect MS2830A and the external PC with LAN cable.

For details about how to set up the network for the MS2830A, see Chapter 1 “Basics of Remote Control” in the MS2690A/MS2691A/MS2692A and MS2830A Signal Analyzer Operation Manual (Main Frame, Remote Control).

C.2 Checking IP address of MS2830A

If the IP address is automatically assigned upon establishing a DHCP connection, check the IP address by using the following procedure:

1. Display the MS2830A desktop.
To display the desktop, right-click anywhere on the screen and select **Show the Desktop**.
2. Display the MS-DOS Prompt. Select **Start – All Programs – Accessories – Command Prompt**.

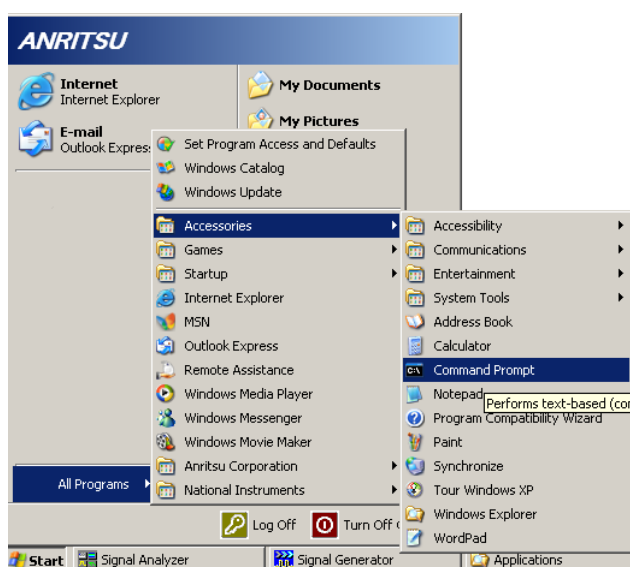

3. Enter the following:
`ipconfig`
The assigned IP address displays as shown.

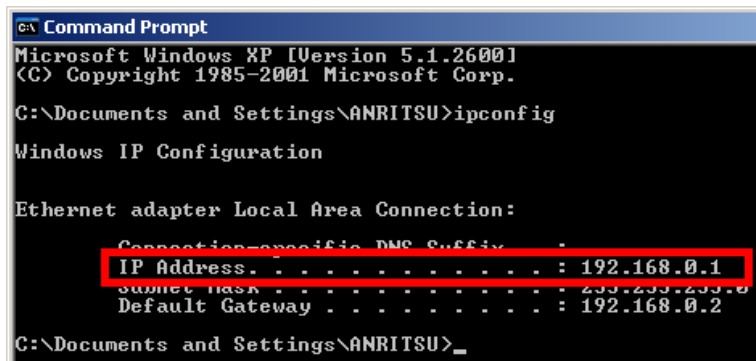

C.3 Configuring shared settings

Simple File Sharing is enabled for the equipment by default. If authentication is performed by way of a network while Simple File Sharing is enabled, the accessing user is regarded as having a Guest account and cannot access important folders and files such as the Windows folder. To avoid this, use the following procedure to temporarily disable Simple File Sharing.

1. On MS2830A, click the **Start** button and then click **My Computer**.
2. In the **Tool** menu, click **Folder Options**, and click the **View** tab.
3. From the **Advanced Settings** list, make sure that the **Use simple file sharing (Recommended)** is NOT selected.

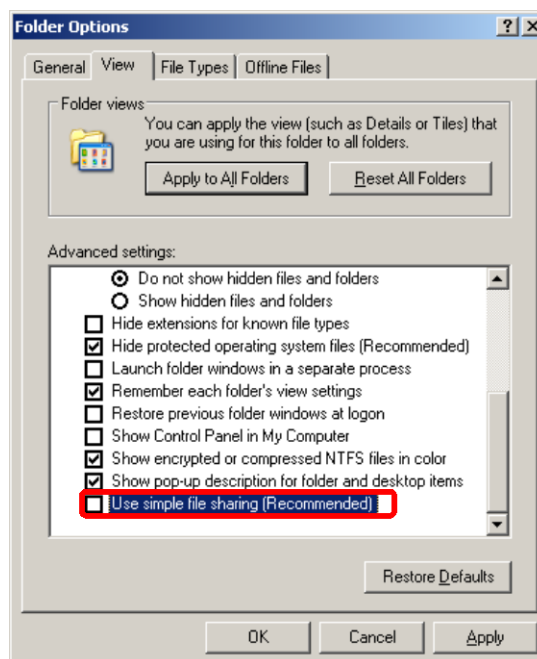

4. Click **OK**.

C.4 Changing the user account for the equipment

This section describes how to change the user account used when the equipment drives are mounted to network drives.

1. From the Start menu, select **Control Panel**.
2. Select **Administrative Tools** from the Control Panel.

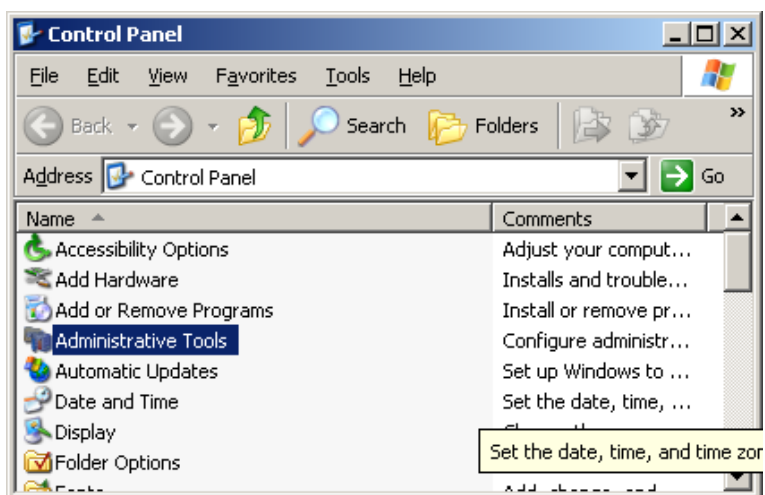

3. Select **Computer Management**.

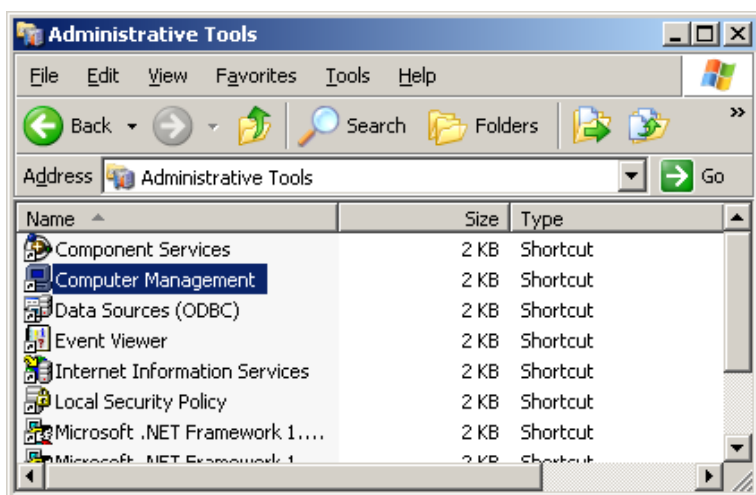

4. In the Computer Management tree, select **Users** under **Local Users and Groups** and **Groups**.

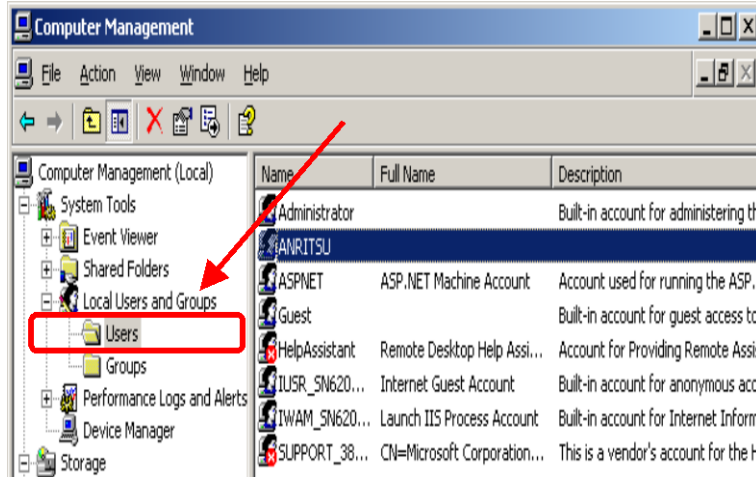

5. Right click the user account “ANRITSU” to use, and select **Set Password....**

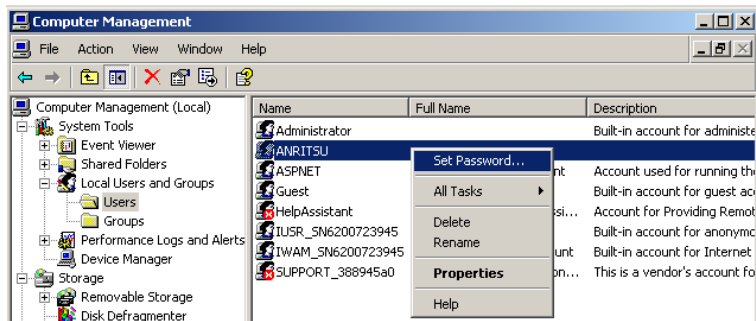

6. When the message below is shown, select **Proceed**.

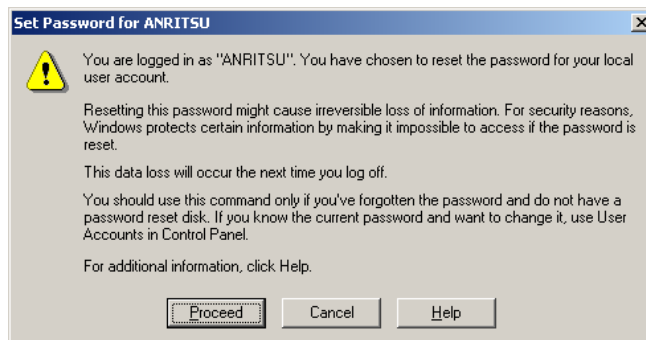

7. Type ANRITSU for the password. You do not actually type brackets [] here.



8. Confirm and click **OK**.

C.5 Shared Settings for MS2830A

1. From the **Start** menu, select **My Computer**.
2. Right-click the C drive.
3. Select **Sharing and Security**.
4. Select the **Sharing** tab.

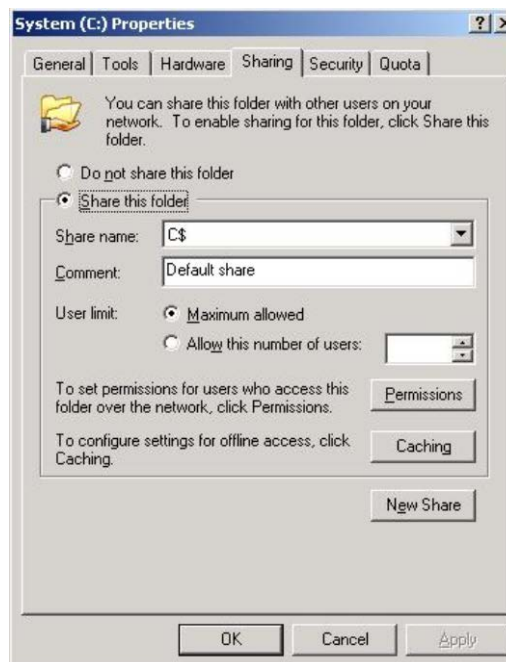

5. To disable currently enabled folder sharing setting, select **Do not share this folder**.
6. Click **Apply**.



- A dialog appears. Select **Yes**.

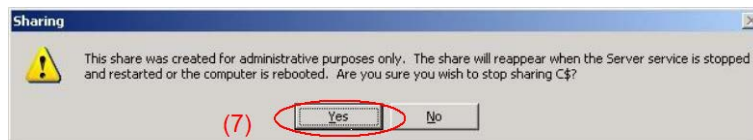

- Select **Share this folder**.
- Click **Permissions**.

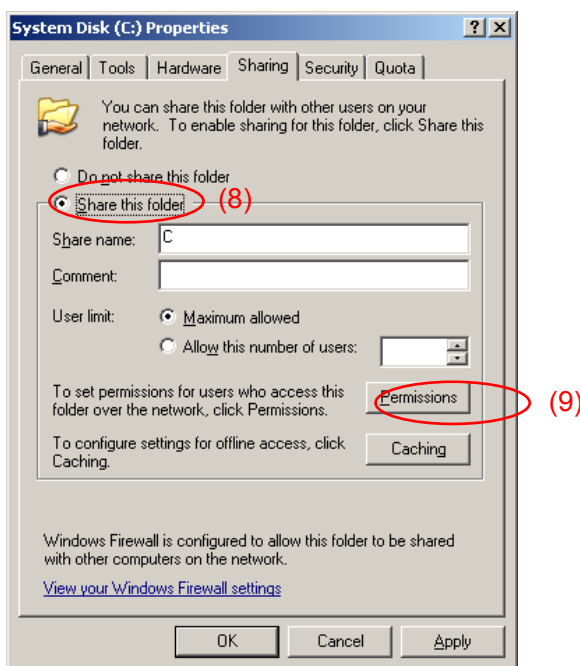

- Select **Allow** for **Full control**.

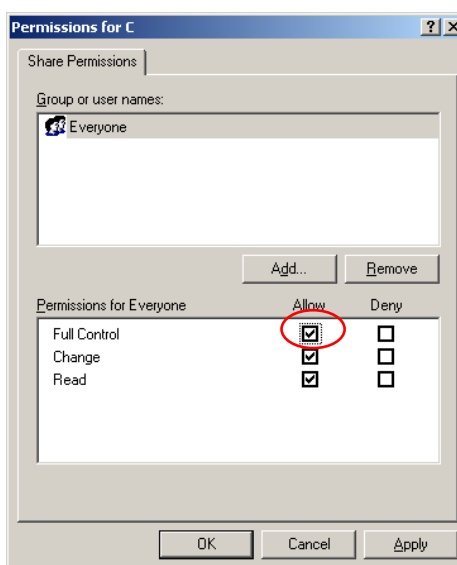

- Click **OK** to close the dialog(s) displayed.
- Repeat steps 3 to 11 to the D drive.

C.6 Mounting the equipment drives to the external computer drives

1. On the computer connected by way of the network (which is used to run the virus scanning software), mount (assign) all the shared drives of the MS2830A as network drives.
2. On the PC, right click **My Network Places**, and select **Map Network Drive**.
3. Enter “The IP address of MS2830A + drive name” for the folder name.

Example When the IP address of the MS2830A is 192.168.0.1:

To mount the C drive, specify Y for Drive and [\\192.168.0.1\c](#) for Folder.

To mount the D drive, specify Z for Drive and [\\192.168.0.1\d](#) for Folder.

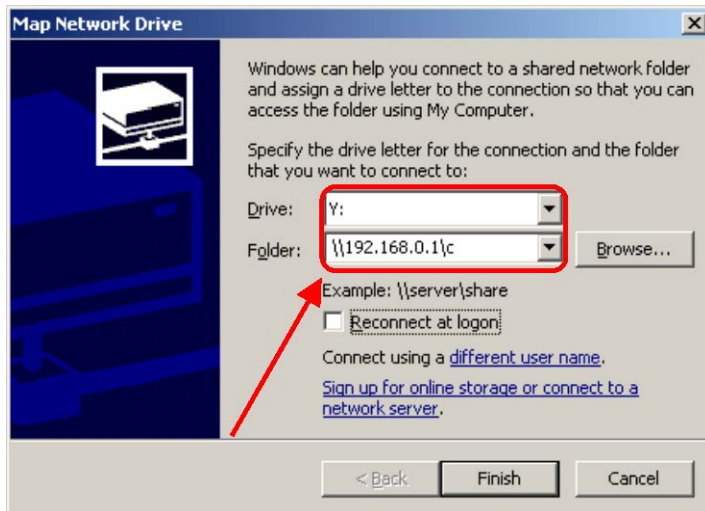

4. Click **Connect using a different user name**.
5. Enter ANRITSU for the User name, and also ANRITSU for the Password (as specified in C.4, Step 7).

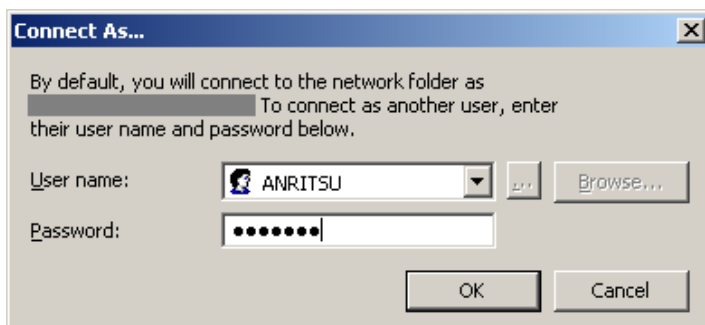

6. Click **OK – Finish** to complete.
7. Repeat steps 2 to 6 to the D drive.

C.7 Scanning for virus

Scan the network drives mounted on the external computer for viruses.

Even if network drives cannot be scanned using your software, scanning might be possible by dragging and dropping a network drive onto the virus software icon in Windows Explorer.

C.8 Unmounting the equipment drives from the external computer drives

Right click **My Network Places** on the external PC, and select **Disconnect Network Drive**.

Unmount the two mapped drives.

C.9 Making the equipment drives unshared

1. From the **Start** menu, select **My Computer**.
2. Right-click the C drive.
3. Select **Sharing and Security**.
4. Select the **Sharing** tab.
5. Select **Do not share this folder**.
6. Repeat steps 2 to 5 to the D drive.

C.10 Restoring the previous user account setting for the equipment

The user password has been changed in Section C.4 "Changing the user account for the equipment" for mounting the equipment drives to network drives of the external computer. Restore the password before change in the same way as it was changed. Note that no password is specified by default.

C.11 Enabling Simple File Sharing

Simple File Sharing has been disabled in Section C.3 “Configuring shared settings” for sharing drives. To restore the original settings, enable Simple File Sharing by using the following procedure:

1. On MS2830A, click the **Start** button and then click **My Computer**.
2. In the **Tool** menu, click **Folder Options**, and click the **View** tab.
3. From the **Advanced Settings** list, make sure that the **Use simple file sharing (Recommended)** is selected.

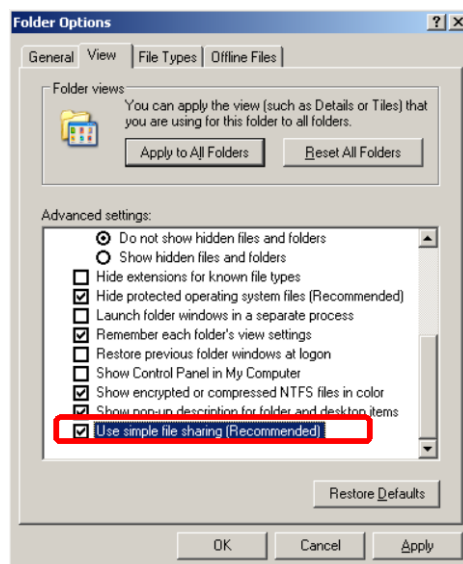

4. Click **OK**.

Appendix D Error Messages

Table D-1 BER function errors

Message	Description
Out of Range.	The settable range is exceeded.
This can't be used because it in Continuous Mode.	This function cannot be used because Continuous mode is selected for MeasureMode.
This can't be used because PNxFix isn't selected.	This function cannot be used because PN_Fix is selected for DataType.
This can't be used because user defined pattern isn't loaded.	This function cannot be used because a user-defined pattern file is not loaded.
This can't be used because user defined pattern isn't selected.	This function cannot be used because a user-defined pattern file is not selected.
No file to read.	No readable file can be found.
Bit pattern is too long.	Cannot be read because the user-defined pattern length is larger than 1024 bits.
Bit pattern is too short.	Cannot be read because the user-defined pattern length is smaller than 8 bits.
Illegal character exists.	Cannot be read because the user-defined pattern contains characters other than "0", "1", a line feed, or a comment marker.
This can't be used because Data is Invalid status.	This function cannot be used when Data is invalid.
This can't be used because MeasureMode is Invalid status.	This function cannot be used when MeasureMode is invalid.
This can't be used because CountMode is Invalid status.	This function cannot be used when CountMode is invalid.
This can't be used because AutoResync is Invalid status.	This function cannot be used when AutoResync is set to Off.
This can't be used because UserDefine isn't selected.	This function cannot be used when UserDefine is selected for Data Type.

Appendix E Initial Value List

<BER measurement functions>

Data type	PN9
Measurement termination condition	Data
Measurement mode	Continuous
Measurement bit count	1000 bits
Measurement bit error count	1 bit
Auto Resync	On
Threshold	200/500
at SyncLoss	Count Clear
PN Pattern Initial	ALL1
PN_Fix_Pattern Length	96 bits
Start bit of the section for judging synchronization establishment	1 bit
Length of the section for judging synchronization establishment	32 bits
User-defined pattern loading source	D drive
Data polarity	Positive
Clock polarity	Rise
Enable polarity	Disable

References are to page numbers.

1

1st Local Output connector..... 3-7

A

AC inlet 3-10

Accessory..... 7-10

Analysis band calibration 3-14

Anritsu Warranty viii

Appli key 3-6

Application key 3-6

Application Switch Settings 3-17, 3-31

Application synchronization 7-9

Applications Software 1-9

Associated Documents I

Auto Calibration..... 3-13

AUX connector..... 3-9

Averaging.....7-11

B

Back key..... 3-3

Band Cal 3-13, 3-14

BER Measurement..... 8-2

Board Revision View 3-24

Buffer Out connector..... 3-8

C

Cal key 3-3

Cancel key..... 3-5

Cautions against computer virus infectionxi

CE Conformity Marking xiii

Close..... 3-13, 3-17

COM Port..... 7-4

Configuration..... 3-17

Copy Data 3-25

Copy key..... 3-2

Copy Settings..... 3-17

Correction 3-17, 3-26

Correction (On/Off)..... 3-27

Crossed-out Wheeled Bin Symbol xii

C-Tick Conformity Marking xv

Cursor keys..... 3-5

D

Digitizer Data 3-25

Displaying Windows Desktop 5-3

E

E-ATT 3-21

Electronic attenuator 3-21

Electrostatic..... 2-6

Enter key..... 3-5

Equipment Certificate..... viii

Ethernet connector 3-9

external display 5-8

F

File Operation..... 3-17

FPGA Version View 3-24

Front Panel 3-2

Function keys..... 3-3

G

GPIB connector..... 3-9

H

Hard disk access lamp 3-2

HDD slot 3-10

I

IF output connector 3-10

Information Save 3-24, 3-49

Initializing 3-48

Installation Location 2-2

Installing software 3-50

Installing software licenses 3-52

Interface Settings 3-17

L

Level Cal 3-13, 3-14

Level calibration 3-14

level offset 7-8

Lifetime of Parts..... x

Load Application Select..... 3-23, 3-31

Local key 3-3

Index

Local Leak Suppression 3-13, 3-14, 3-15

M

M-ATT 3-21

Mechanical attenuator 3-21

Modulation control key 3-6

Monitor Out connector 3-10

N

Next key 3-3

Notes On Export Management..... x

Notice x

Numeric keypad 3-5

O

Open Recall Menu 3-47

Open Save Menu 3-47

Option Information 3-17

Options..... 1-4

P

Parameter Save Data..... 3-25

Position Change..... 3-23, 3-36

Power Meter 7-2

power sensor 7-2

Power Switch 3-2

Preset All Application 3-48

Preset key 3-3

Product Configuration 1-3

Product Overview 1-2

R

range 7-7

Rear panel..... 3-8

Recall all Application 3-42

Recall Correction Table..... 3-27, 3-28

Recall Current Application 3-41, 3-42

Recall key..... 3-2

Ref Input connector..... 3-8

reference frequency signal..... 3-8

Reference frequency signal..... 3-17

Remote lamp..... 3-3

reverse power..... 2-5

RF Input connector 3-5

RF output connector..... 3-6

RF output control key 3-5

Rotary knob..... 3-5

S

SA key..... 3-6

SA Trigger Input connector..... 3-10

Save Application 3-39, 3-40

Save Correction Table 3-27

Save key 3-3

Save Waveform CSV DATA..... 3-40

Save&Recall Mode..... 3-44

Save&Recall Settings..... 3-17

Screen hard copy 3-43

Set Reference 7-11

SG key 3-6

SG Trigger Input connector 3-10

SG Wave License 3-53, 3-56

SG Wave License View 3-24

Shift key 3-5

SIGANA All..... 3-13

Signal Analyzer

 Spectrum analysis 4-2

Simple Recall 3-47

Simple Save 3-46

Simple Save&Recall 3-44

Simple Save&Recall Name 3-44

Software Install

 ... 3-17, 3-26, 3-51, 3-52, 3-53, 3-54, 3-55, 3-56

Software License 3-52, 3-55

Software License View 3-24

Software Version View 3-24

SPA key 3-6

Specifications 1-10

Spectrum Analyzer

 Spectrum analysis 4-6

Standard configuration 1-3

Sweep Status Out connector..... 3-8

System Information..... 3-17, 3-24, 3-25, 3-49

System Information View 3-24

System Recovery..... 5-11

System Reset 3-24, 3-49

System Settings 3-17

T

Title 7-10
Top key 3-3
Trace Data 3-25
Trigger signal..... 3-10

U

Uninstall 3-54, 3-55, 3-56
Uninstalling..... 3-54
Uninstalling software licenses 3-55

Unload Application Select..... 3-23, 3-33

USB connector

 Type A 3-6

 Type B..... 3-9

USB connectors

 Type A 3-10

user data 3-48, 3-49

Z

Zeroing 7-12

