

# Performing Impedance Analysis with the E5061B ENA Vector Network Analyzer

# Table of Contents

- Introduction ..... 3
- Performing Impedance Analysis with the E5061B ..... 4
- Examining Five Commonly Used Measurement Methods ..... 6
- Selecting the Best Method for Your Application ..... 10
- Ensuring Accurate Results: Calibration and More ..... 13
- Examining Real-world Examples ..... 20
- Conclusion ..... 24

# Introduction

There are often times when you need to quickly check or evaluate the DC to RF performance of components and circuits which were previously analyzed with a dedicated impedance analyzer. The convenience of impedance analysis capabilities built into a network analyzer would address this scenario by providing enough dynamic range and RF performance to ensure reliability, signal integrity and EMI performance of your system.

Whether you need to measure basic S-parameters or analyze device or circuit impedance, a vector network analyzer (VNA) with the right mix of speed and performance will give you an edge. In R&D and on the production line, Keysight ENA vector network analyzers provide the throughput, repeatability and reliability you need to perform accurate, dependable tests that transform parts into competitive components. The E5061B ENA vector network analyzer covers 5 Hz up to 3.0 GHz (Option 3L5), addressing low-frequency (LF) and radio-frequency (RF) measurements. With the impedance analysis capability (Option 005), the E5061B addresses a wide range of LF and RF applications.

This application note describes five common impedance analysis approaches used with impedance analyzers and network analyzers. It also describes how and when to use the E5061B for impedance analysis. Major topics include test ports, impedance analysis capabilities, measurement methods, and calibration techniques. The note concludes with a variety of examples ranging from basic component measurements (e.g., inductors and capacitors) to in-circuit impedance measurements.

# Performing Impedance Analysis with the E5061B

The E5061B offers versatile network analysis capabilities from 5 Hz to 500 MHz (Option 3L3), 1.5 GHz (Option 3L4) or 3.0 GHz (Option 3L5). Comprehensive LF measurement capabilities such as built-in 1 M $\Omega$  inputs are seamlessly integrated with the high-performance network analyzer architecture. Core features include S-parameter test ports (50  $\Omega$ ), a gain-phase test port (switchable between 50  $\Omega$  and 1 M $\Omega$ ), and a DC bias source (up to  $\pm 40$  V<sub>dc</sub>).

## Adding impedance analysis

For an E5061B configured with any of the LF-RF network analysis options—3L3, 3L4 or 3L5 (“3Lx” collectively)—Option 005 provides impedance analysis (ZA) firmware. The combination of NA and ZA capabilities further enhances the analyzer’s versatility as a general-purpose R&D tool.

Adding the ZA firmware enables the analyzer to measure impedance parameters of electronic components such as capacitors, inductors, and resonators. Additional functionality includes fixture compensation and equivalent circuit analysis. Biased impedance measurements are possible with the built-in DC bias source provided by options 3L3, 3L4 and 3L5.

With any of the frequency options, E5061B-005 cannot match the ultimate overall performance of a dedicated impedance analyzer. However, it does enable you to apply measurement methods, calibration techniques, and fixturing choices that provide comparably accurate impedance measurements.

## E5061B ENA vector network analyzer

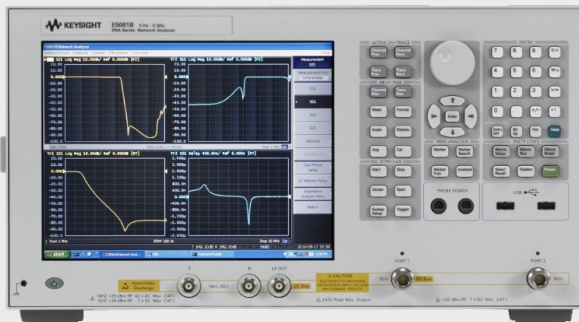

As part of the ENA family, the E5061B is designed to help you drive down the cost of test. It addresses a broad range of needs in the characterization of electronic components and circuits in communications, aerospace, defense, computing, medical, automotive, CATV, and more. You can configure the E5061B with a variety of S-parameter and transmission/reflection test sets as well as options for time-domain/fault-location analysis, impedance analysis, and wireless power transfer analysis.

[www.keysight.com/find/E5061B](http://www.keysight.com/find/E5061B)

## Comparing the test ports

The E5061B-3Lx is equipped with two types of test ports: S-parameter and gain-phase. Let's take a closer look at each type.

The S-parameter test ports (Port 1 and 2) have a built-in 50- $\Omega$  test set that covers the analyzer's full frequency range (Figure 1). In the RF range, the E5061B provides excellent performance equal to that of similar analyzers. The E5061B particularly excels in the LF range, providing coverage down to 5 Hz and better dynamic range in the low-to-middle range below 10 MHz for thorough evaluation of one- and two-port devices such as filters, amplifiers, transformers, and antennas.

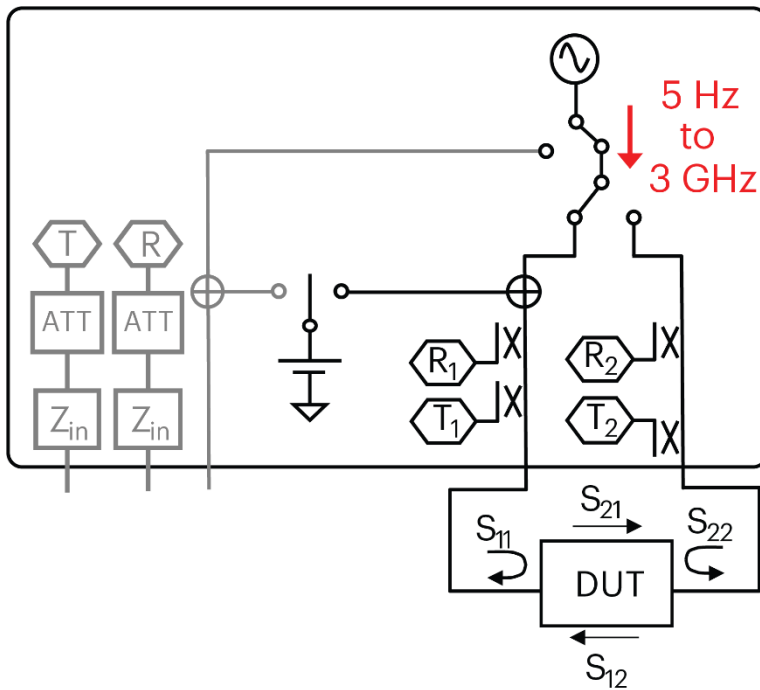

**Figure 1.** The right side of this block diagram shows the S-parameter test ports and test set built into the E5061B-3L5. Note the maximum frequency range is 5 Hz to 3 GHz.

The gain-phase test port has reference and test receiver inputs with the ability to switch between 50  $\Omega$  and 1 M $\Omega$  input impedance (Figure 2). These are used to analyze the frequency response of low-frequency devices and circuits such as op-amps and the control-loop circuits of DC-to-DC converters.

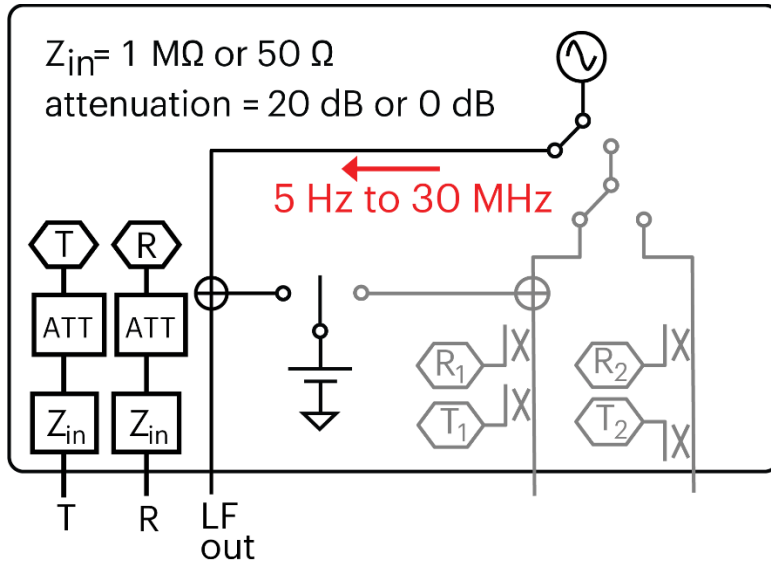

**Figure 2.** The left side of this block diagram shows the gain-phase ports built into the E5061B-3Lx. Note the frequency range is 5 Hz to 30 MHz in this mode

## Examining Five Commonly Used Measurement Methods

If we step back and survey the capabilities of dedicated impedance analyzers as well as network analyzers with ZA capability, there are five commonly used measurement methods. Impedance analyzers typically use either the auto-balancing bridge or RF current-voltage (I-V) method. In the E5061B, the ZA firmware supports three methods: reflection, series-through and shunt-through. The following section describes each method and applicability to specific applications.

### Taking a closer look: Impedance analyzer methods

The Keysight E4990A impedance analyzer is one an example of a low-frequency instrument (20 Hz to 120 MHz) that employs the auto-balancing bridge method. Figure 3 shows a simplified block diagram of the bridge circuit. In this model, a negative feedback loop maintains a specific potential at the low terminal relative to virtual ground (zero volts). This eliminates stray capacitance and enables the voltmeters, V1 and V2, to accurately measure voltage and current with excellent linearity at the device under test (DUT). This method offers the highest accuracy across a very wide range of impedance values.

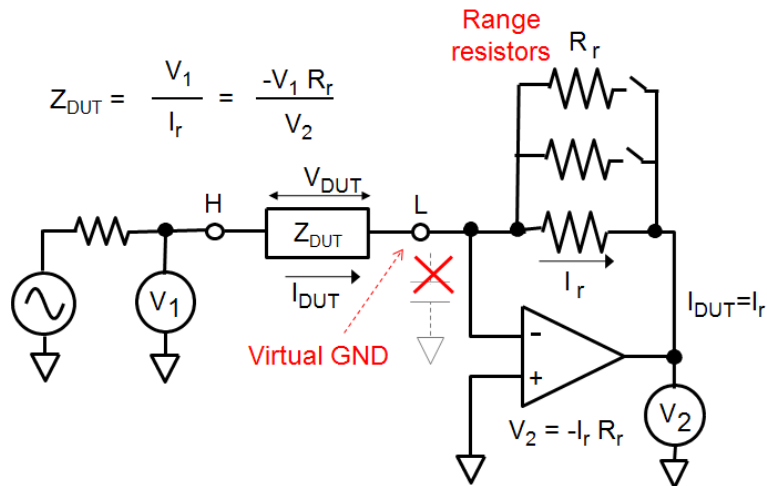

**Figure 3.** The auto-balancing bridge method provides outstanding basic accuracy of 0.08% across a wide range of impedance values

In contrast, the Keysight E4991B impedance analyzer (1 MHz to 3 GHz) uses the RF I-V method (Figure 4). The instrument architecture includes a source/receiver mainframe and a separate test-head module that senses high-frequency voltage and current very close to the DUT. Note, however, that it cannot cover the low-frequency range (e.g., below 1 MHz) because it uses a current-sensing transformer.

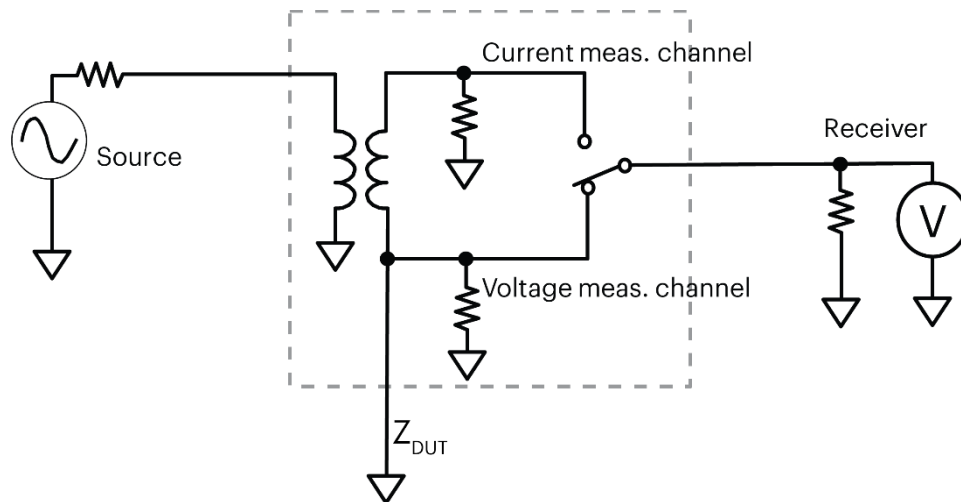
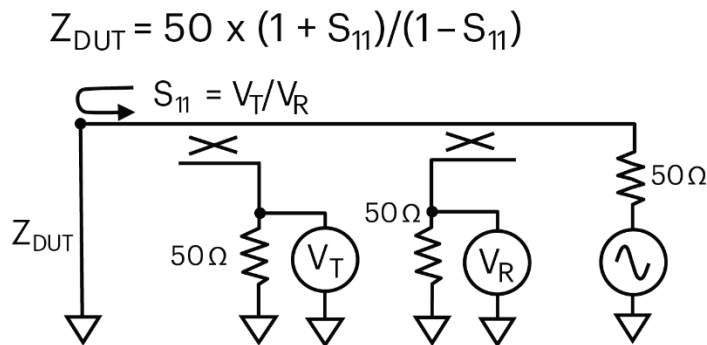

**Figure 4.** Although the RF I-V method is less accurate than the auto-balancing bridge, it is more accurate than the VNA-based reflection method; it also has a wider measurement range.

## Taking a closer look: Network analyzer methods

The optional ZA firmware for the E5061B supports the reflection, series-through and shunt-through methods. In addition, the series- and shunt-through methods can be used with either the gain-phase or S-parameter test ports. Each approach has advantages over specific frequency and impedance ranges.

Traditionally, the reflection method has been most commonly used in the middle- and high-frequency ranges. Using the familiar scattering parameters (S-parameters) from vector network analysis, the reflection method derives impedance values from S11 measurement data (Figure 5).



**Figure 5.** A simple math operation relative to S11 and the 50-Ω input impedance produces the impedance of the DUT

In terms of impedance values, the 10% accuracy range is about 1 Ω to 2 kΩ (supplemental performance data), and this is a bit narrower than what is possible when using the RF I-V method in a dedicated impedance analyzer. The reflection method is the better choice when lower frequency coverage is needed, and this is made possible by the broadband S-parameter test set in the E5061B-3Lx.

The series-through method measures impedance by connecting the DUT in a “transmission series” connection, as shown in both block diagrams in Figure 6. As noted earlier, you can use this method with either the gain-phase or S-parameter test ports. Series-through is most effective when measuring high impedance values: the 10% accuracy range is about 5 Ω to 20 kΩ or roughly one decade higher than the reflection method.

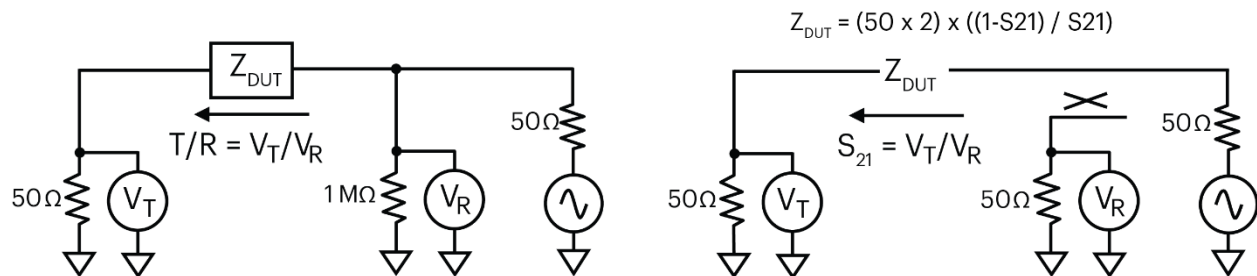
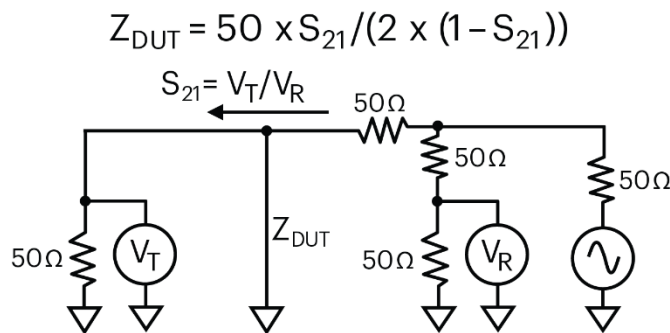

**Figure 6.** Depending on the impedance range of interest, you may want to use the series-through method with the gain-phase port (left) or the S-parameter port (right). As suggested by the diagrams, you cannot measure a grounded DUT with this method.



Using the gain-phase port offers the convenience of directly connecting four-terminal pair-type component test fixtures; its maximum frequency is 30 MHz. You can reach higher frequencies with the S-parameter test port and your own custom test fixture. Note that the maximum measurement frequency is in the range of 200 MHz to 300 MHz because it is difficult to fully eliminate measurement errors around the series-through fixture at frequencies above a few hundred megahertz.

The shunt-through method measures impedance by connecting the DUT in the transmission-shunt configuration shown in Figure 7. This is good way to characterize very low impedance values, and it is commonly used to make measurements in the milliohm range (e.g., power integrity applications). With the gain-phase port the 10% accuracy range spans 1 mΩ to 5 Ω, which is lower than typical impedance analyzers can reach.



**Figure 7.** Similar to the reflection measurement, a simple math operation relative to  $S_{21}$  and the 50-Ω input impedance produces the impedance of the DUT.

For low-impedance measurements above 30 MHz, using the shunt-through method with the S-parameter port is the best solution. When measuring below 100 kHz, we recommend using the gain-phase port because its unique semi-floating receiver architecture eliminates the measurement errors caused by ground loops.<sup>1</sup> Figure 8 shows the respective connections to the E5061B.

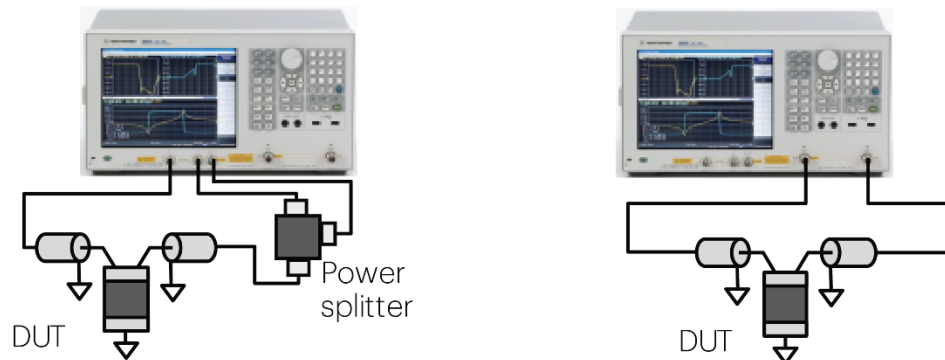
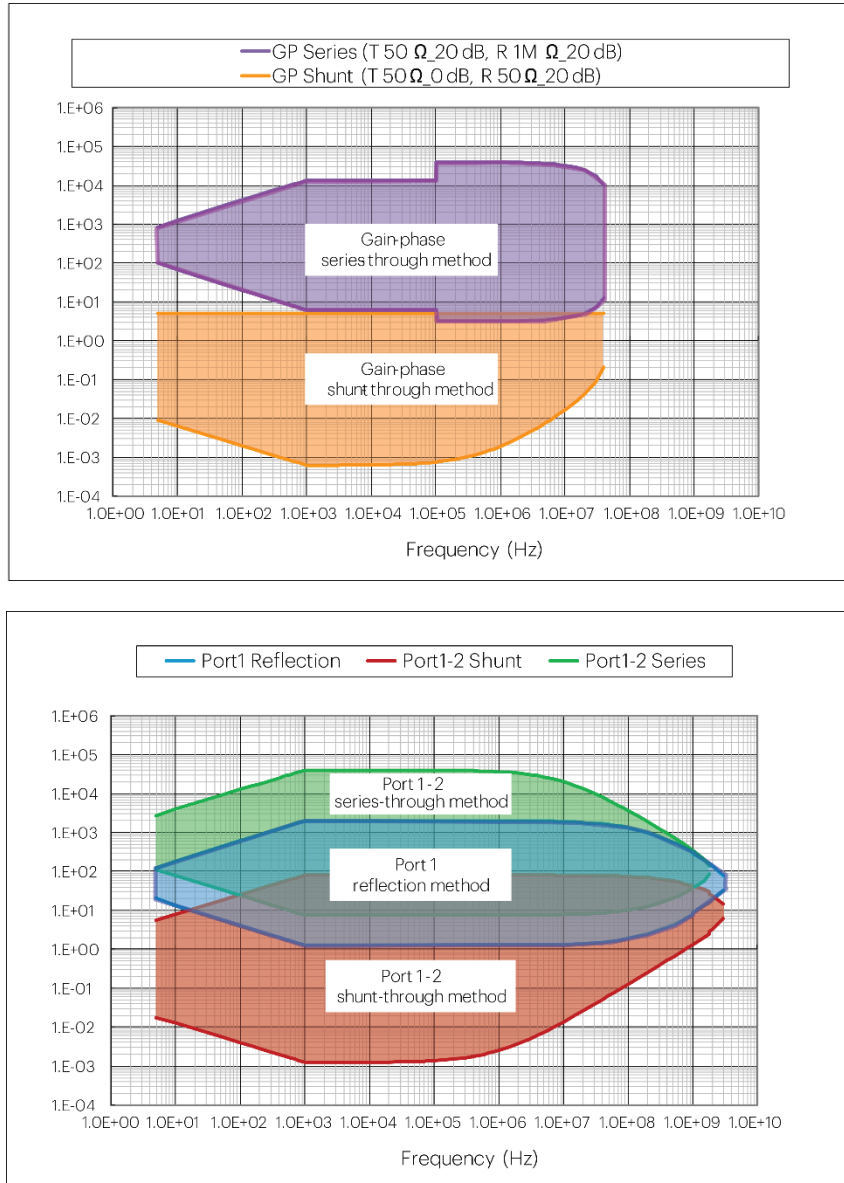

**Figure 8.** When using the shunt-through method with the gain-phase port (left), use a power splitter between the reference input and the DUT input. This is not necessary with the S-parameter port (right) because the analyzer has a built-in directional bridge.

<sup>1</sup> For more information about the semi-floating architecture, please see page 17 of the application note Evaluating DC-DC Converters and PDN with the E5061B LF-RF Network Analyzer, publication 5990-5902EN.

# Selecting the Best Method for Your Application

As a visual summary of the preceding section, Figure 9 provides a graphical comparison of the respective 10% accuracy ranges versus impedance and frequency for all five methods.



**Figure 9.** These graphs show the best frequency and impedance ranges for each of the measurement methods specific to either the gain-phase (upper) or S-parameter (lower) test ports <sup>1</sup>

<sup>1</sup> Notes for Figure 9: The lower-right portion of the orange area (upper graph) was affected by 20 pH of residual inductance; the lower-left portion of the red area (lower graph) was affected by use of magnetic cores to measure very low impedance at low frequencies; the lower-right portion of the red area was affected by 20 pH of residual inductance.

Table 1 provides a summary that will help you select the best measurement method for your application. Note the short lists of example DUTs in the right-most column.

Frequency range	Impedance range	Recommended port and method	Example DUTs
Below 100 MHz	Less than 100 mΩ	Gain-phase with shunt-through up to 30 MHz; S-parameter (Port 1-2) with shunt-through above 100 kHz	DC-DC converters; mid- or large-size bypass capacitors; power distribution networks (PDNs)
	1 Ω to 10 kΩ	S-parameter (Port 1-2) with reflection	Inductors, transformers, resonators
	Greater than 10 kΩ	Gain-phase with series-through up to 30 MHz; S-parameter (Port 1-2) with series-through up to 300 MHz	Small capacitors, resonators, inductors and transformers
Above 100 MHz	Less than 100 mΩ	S-parameter (Port 1) with shunt-through	Small bypass capacitors; PDNs
	1 to 2 kΩ	S-parameter (Port 1-2) with reflection	RF inductors and capacitors; other RF passive components

**Table 1.** The attributes of your application will help you determine which VNA-based method will provide the best results

As a final comment, we recommend a dedicated impedance analyzer such as the E4990A and E4991B in the following cases:

- You need very high measurement accuracy (e.g., less than 1%)
- You need to measure high impedance values (>10 kΩ) very accurately
- You need to measure devices with very high Q ( $X/R > 100$ ) or very low D ( $R/X < 0.01$ )
- You need to measure magnetic or dielectric materials

Please see the next page “Achieve unparalleled accuracy” for more information about the E4990A and E4991B.

## Achieve unparalleled accuracy



Keysight's E4990A and E4991B impedance analyzers let you see the real characteristics of your components from milliohm to megohm. Both are available with a variety of frequency options to meet current needs and budgets, and frequency upgrades make it easy to meet future requirements.

The E4990A covers 20 Hz to 10, 20, 30, 50 or 120 MHz and delivers an industry-best basic accuracy of 0.045% (typical) over a wide impedance range; it also includes a built-in 40 V DC bias source. The E4991B covers 1 MHz to 500 MHz, 1.0 GHz or 3.0 GHz and provides basic accuracy of 0.65% over a wide impedance range; a built-in 40 V DC bias source is available (Option 001). The E4991B also offers materials-measurement options including analysis of temperature characteristics (Option 007) and direct readings of permittivity and permeability (Option 002).

## Migrate to the latest capabilities



Our previous-generation network/impedance combination analyzers, carrying the HP or Agilent brand, are widely used for component characterization. If you are looking to upgrade to the latest capabilities, we have four recommended migration paths, three of which are based on the E5061B with the 3 GHz frequency range and impedance analysis firmware (Options 3L5 and 005, respectively).

If you are using either the 4195A+41951A or the 4395A/96x+43961A to measure high impedances, we recommend the E5061B configuration with the reflection method. If you need to reach higher frequencies or are measuring low impedances, we recommend the E5061B-3L5/005 and the gain-phase test port with the series-through method. For milliohm measurements of large capacitors or DC-to-DC converters, consider the E5061B configuration and the shunt-through method. Finally, we recommend the E4990A or E4991B impedance analyzers if you are measuring high-Q/low-D devices.

## Ensuring Accurate Results: Calibration and More

In network analysis and impedance analysis, we can improve measurement accuracy by removing the systematic errors caused by the test setup: instrument, cables, connectors, fixtures, and so on. When performing impedance analysis with a network analyzer, this error-correction or “calibration” process can involve a variety of techniques and accessories (i.e., “cal standards”). This section starts with a brief look at calibration in two-port network analysis, using it to provide context for error-correction as applied to the reflection, series-through and shunt-through measurement methods.

## Calibration for two-port network analysis

The series-through and shunt-through methods are based on a two-port transmission measurement. If we use an  $S_{21}$  measurement configuration with  $50\text{-}\Omega$  system impedance, then we can apply VNA calibration methods such as response-through and two-port full—short, open, load, through or “SOLT”—when making impedance measurements.

Response-through uses characterization of a “thru” standard to eliminate magnitude and phase-shift errors. SOLT uses a series of measurements to eliminate the bidirectional error factors—transmission and reflection—present in the two-port measurement system (Figure 10).

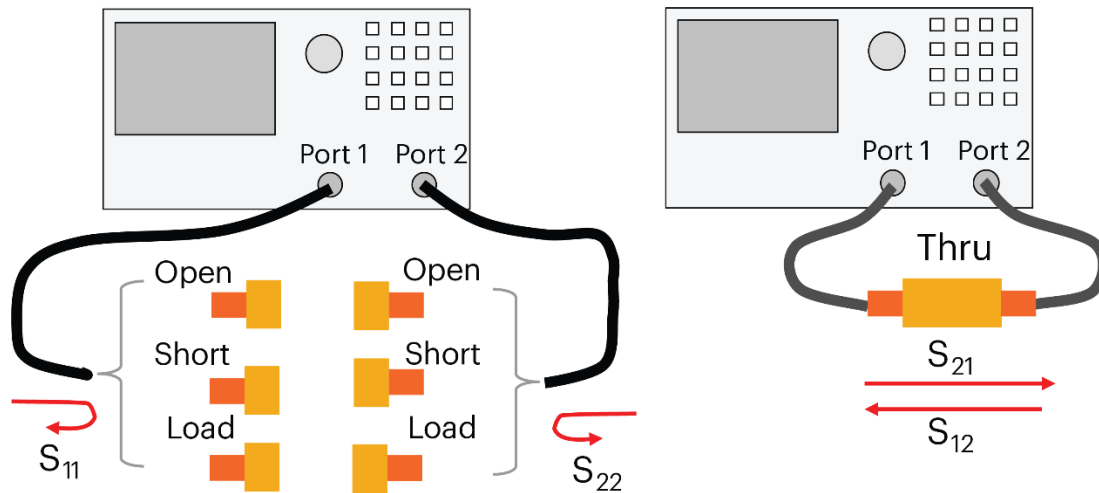

**Figure 10.** A full two-port calibration with the SOLT method requires a cal kit containing four standards—three impedance and one transmission—and is used to define the calibrated reference plane.

## Calibration for impedance analysis

Focusing solely on impedance measurements, we can instead treat the network analyzer as a linear measurement system (e.g., just another black box) and apply the simpler open/short/load calibration technique (Figure 11).

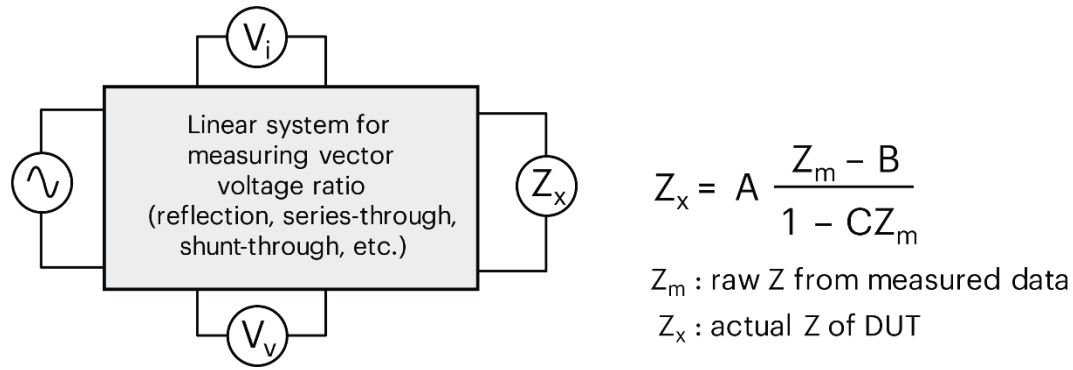

**Figure 11.** The calibration process derives the three complex-valued coefficients A, B and C by measuring open, short and load standards with known Z values.

The black-box model is valid if it satisfies these conditions:

- It is operating in the linear region of its response (e.g., no gain compression or distortion)
- We can distinguish the open, short and load standards with measured voltages
- The load device remains stable during the measurement process

To automate and simplify the process, the E5061B-005 impedance firmware provides an Impedance Calibration function that can be used with all three measurement methods—reflection, series-through and shunt-through.

## Calibrating for the reflection method

The typical approach is to calibrate the measurement plane defined at the 7 mm coaxial connectors. In the E5061B, this uses the “port extension” (i.e., electrical length) fixture model to compensate for the phase shift in the coax section. In addition, the open-short compensation will eliminate the effects of stray capacitance and residual inductance around the fixture’s electrodes.

When performing the open/short/load calibration at the 7 mm connector plane, you can use either the Impedance Calibration function or the conventional full one-port calibration function. With Impedance Calibration, you can perform a low-loss capacitor calibration with an air capacitor (included with the 16195B cal kit) in addition to the open/short/load cal (Figure 12). This will improve the accuracy of phase, Q or D measurements above 300 MHz by reducing the phase uncertainty of the 50-ohm load termination.

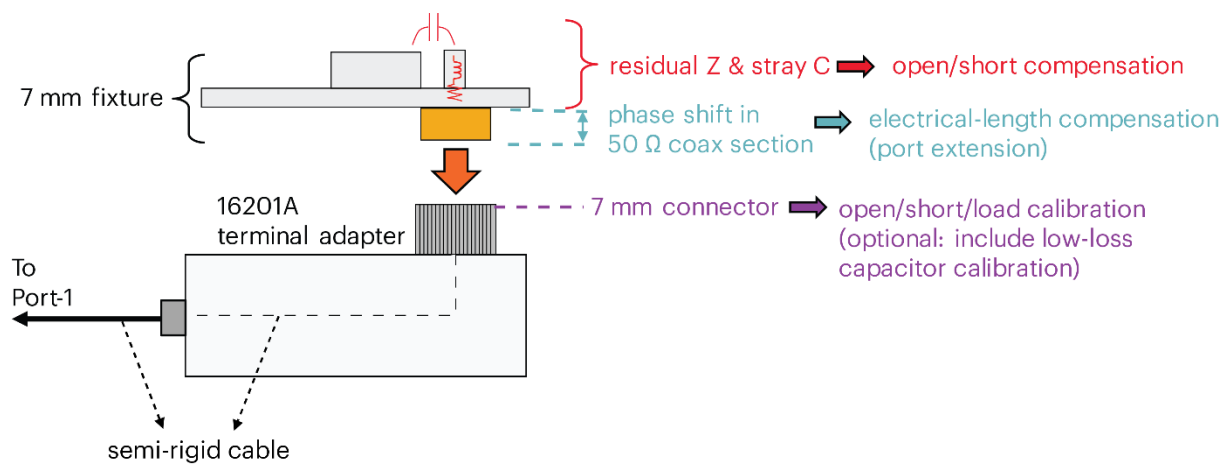
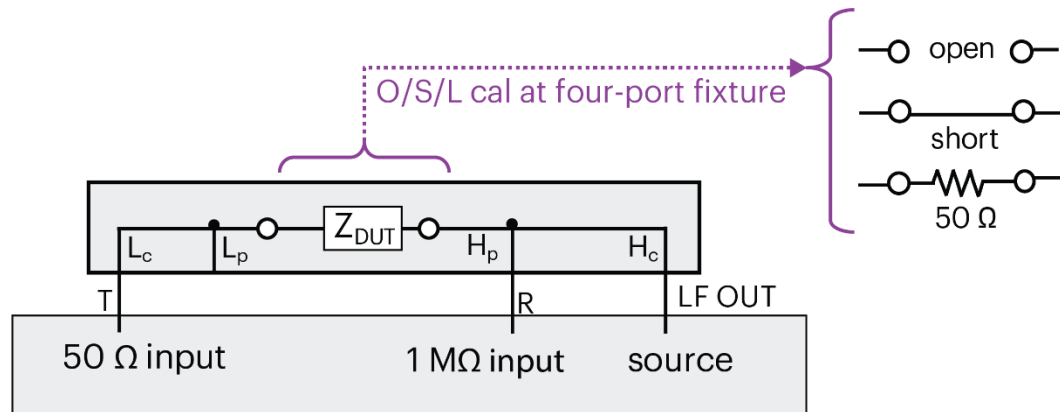

**Figure 12.** Combining the three techniques shown here will compensate for systematic effects out to the measurement plane at the 7 mm connector



## Calibrating series-through

With series-through and the gain-phase test port, the typical approach is to use an open/short/load calibration at the four-port fixture (Figure 13). To enhance the accuracy of this technique, we offer 50  $\Omega$  resistors (leaded and SMD-type) as accessories to the E5061B (Option 720).



**Figure 13.** This approach ensures better results when measuring small capacitors, resonators, inductor and transformers up to 30 MHz

For measurements using the S-parameter test port above 30 MHz, the most practical method is a SOLT calibration at the coaxial cables plus the port extension to compensate for the transmission lines on the user-prepared test board. As an additional step, you can perform an open compensation to remove stray capacitance at the measurement terminals (Figure 14).

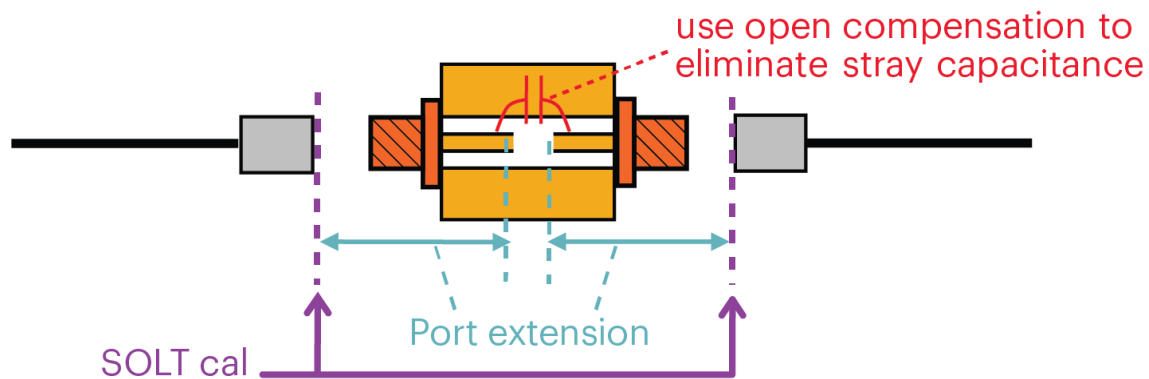

**Figure 14.** This method provides better results when measuring small capacitors, resonators, inductors and transformers up to 300 MHz

## Calibrating shunt-through

We use the gain-phase port and the shunt-through method when measuring low impedances at low frequencies. In this case, a simple response-through calibration is usually the best choice because it provides sufficient accuracy in the milliohm range. This is true when measuring either the absolute value of the impedance or the capacitance and inductance elements of complex-valued impedance.

If you need to measure impedances greater than  $1 \Omega$ , or if you are measuring phase or equivalent series resistance (ESR) at higher frequencies, then we recommend the open/short/load calibration. This will remove more error factors than is possible with the response-through method.

The process becomes a bit more complex when using the S-parameter test port to make measurements into the megahertz or gigahertz range. In this situation, the best choice is a SOLT calibration at the coaxial cables plus the port-extension procedure to compensate for fixtures and probes (Figure 15). When using an RF probe station, perhaps when characterizing IC packages or printed-circuit boards, you should perform a SOLT calibration at the ends of the probes using calibration standards provided by the probe manufacturer.

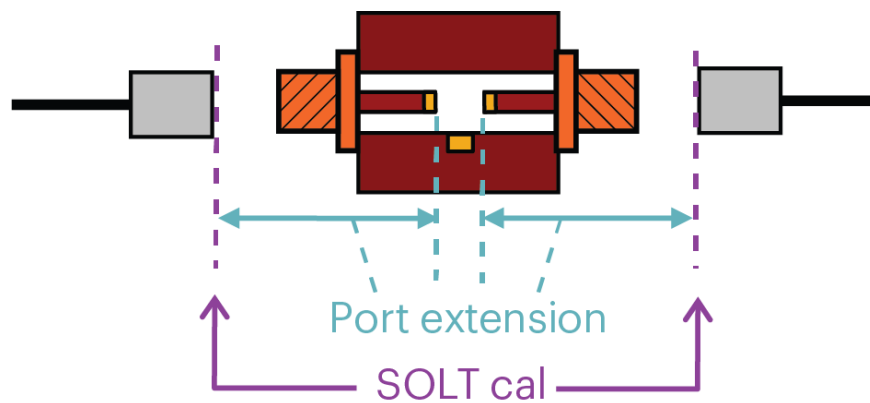

**Figure 15.** At higher frequencies, combining SOLT and port extension provides more accurate results with the Port 1-2 shunt-through method.

## Enhancing measurement accuracy

A few more tips will help you get better results when using the E5061B network analyzer. As an overall suggestion, it is best to set the source for moderate power levels: this helps ensure that the receivers are operating in regions of sufficient linearity. For example, set the power level to less than 0 dBm when using the reflection method. This will help prevent the expansion of S-parameter errors after conversion to the impedance domain. A level of less than  $-10$  dBm is desirable when measuring small resistance values in reactive devices with high Q (or low D).

Specific to the series-through method, we recommend using fixtures that hold the  $50\ \Omega$  load very tightly. Examples of such fixtures include the Keysight 16047E (leaded DUTs) and the 16034E/G/H for SMD devices.

Four more tips will improve your results with the shunt-through method. First, always inspect your cables and connectors for damage: it can increase outer-shield resistance and offset the benefits of semi-floating receivers and magnetic cores. Second, use good technique when probing above 10 MHz: this will ensure that you minimize the inductive errors that may be caused by inter-probe coupling.

Tip #3: If you are performing an open/short/load calibration, enter the resistance and inductance values from the cal kit definitions: this will avoid an excessive number of subtraction operations in the milliohm range. You can obtain those values by measuring a short using the gain-phase shunt method with a through calibration.

Fourth, use two-port contact to minimize the effect of contact resistance. As shown in Figure 16, contact resistances are in series with the analyzer's  $50\text{-}\Omega$  system impedance, which is much greater than  $R_c$ . Consequently,  $R_c$  will have much less effect on the measurement. In addition, the residual inductances at (a) and (b) will also have less impact on your results. At high frequencies, phase shifts at (a) and (b) will affect your measurements. You can compensate for this in either of two ways: when using through calibration, use a through device with length equal to (a)+(b); when using SOLT, use the port-extension function.

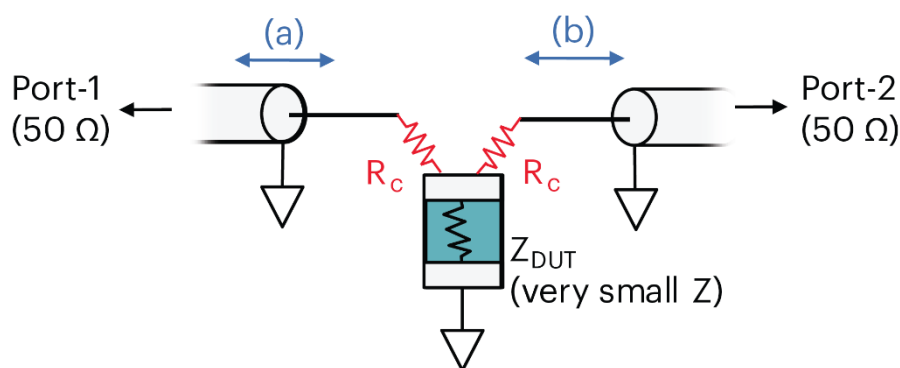

**Figure 16.** A two-port contact provides a variety of benefits when using the shunt-through method

# Examining Real-world Examples

A few typical measurement scenarios will illustrate the benefits of the techniques presented in the preceding sections: inductors and capacitors; a crystal resonator; DC-biased measurements; and circuit impedance.

## Characterizing inductors and capacitors

For basic component measurements, the E5061B can accurately measure impedance if you choose the most effective method and apply the recommended tips. A general set of examples includes using the reflection method with a 100 nH inductor, the gain-phase series-through method with a 10 nF capacitor, and the gain-phase shunt-through method with a 200  $\mu$ F capacitor.

One way to assess the results is to compare E5061B measurements with those made with dedicated impedance analyzers. In the inductor example it takes two impedance analyzers to cover the full frequency range of the E5061B (5 Hz to 3 GHz). Figure 17 shows overlays of results obtained with the E5061B, 4294A and E4991A (predecessors of the E4990A and E4991B, respectively). Note that measurements from the 4294A (orange) cover 10 kHz to 100 MHz; the E4991A (purple) covers 1 MHz to 3 GHz. Clearly, there is good data agreement in the results for inductance (upper trace) and Q (lower).

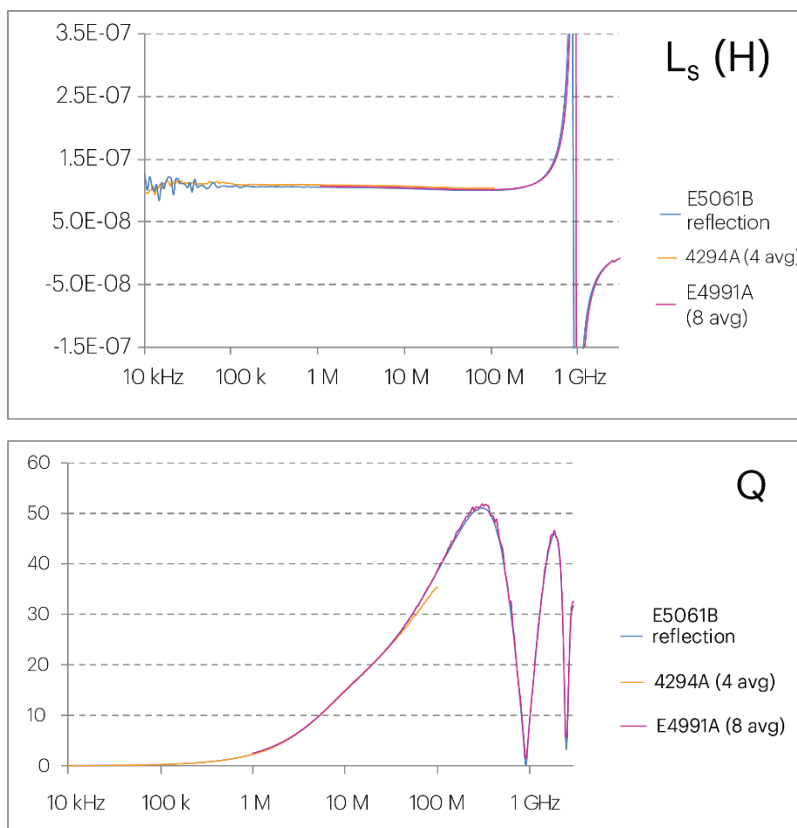

**Figure 17.** The E5061B delivers comparable results for an inductor with moderate  $|Z|$  and Q values that are relatively easy to measure

Applying the suggestions presented in this note, settings for the E5061B were 10 kHz to 3 GHz,  $-10$  dBm source level and 30 Hz IF bandwidth. Error-correction methods were open/short/load calibration plus low-loss capacitance calibration, port extension, and open-short compensation.

## Characterizing a crystal resonator

A high-Q crystal resonator provides additional insight into the process of making successful impedance measurements with a network analyzer. Figure 18 shows magnitude (top, blue) and phase (bottom, red) responses in a 30 kHz span centered at 14.4 MHz. The resonant and anti-resonant frequencies are clearly visible in both traces: in the magnitude trace  $F_r$  is the notch on the left and  $F_a$  is the peak on the right; those correspond to the zero-crossing transitions in the phase trace.

The lower-left corner of the display shows the  $R_1$ ,  $C_1$ ,  $L_1$  and  $C_0$  values computed by the equivalent circuit analysis function in the E5061B-005:  $R_1$  is  $14.4 \Omega$ ,  $C_1$  is  $7.3$  fF,  $L_1$  is  $16.7$  mH, and  $C_0$  is  $2.8$  pF. However, the upper-left readout for marker 1, which is in the resonance at  $14.4$  MHz, shows a value of  $21.3 \Omega$  for  $|Z|$  at zero degrees phase). Unfortunately, this is higher than the known  $C_1$  value for the DUT.

To accurately measure  $C_1$ , it is necessary to use a slower sweep rate and increase the number of measurement points around the resonance. Figure 19 shows a measurement made with a narrower span around the resonance: this yields a smaller IF bandwidth, which reduces the sweep rate and provides greater resolution in the area surrounding  $F_r$ . In this case the value for  $C_1$  is  $14 \Omega$ , which is correct. One caveat: Because the anti-resonance is not within the measurement span, the equivalent circuit model will produce an erroneous value for  $C_0$  (in this case  $2.89$  pF rather than  $2.77$  pF).

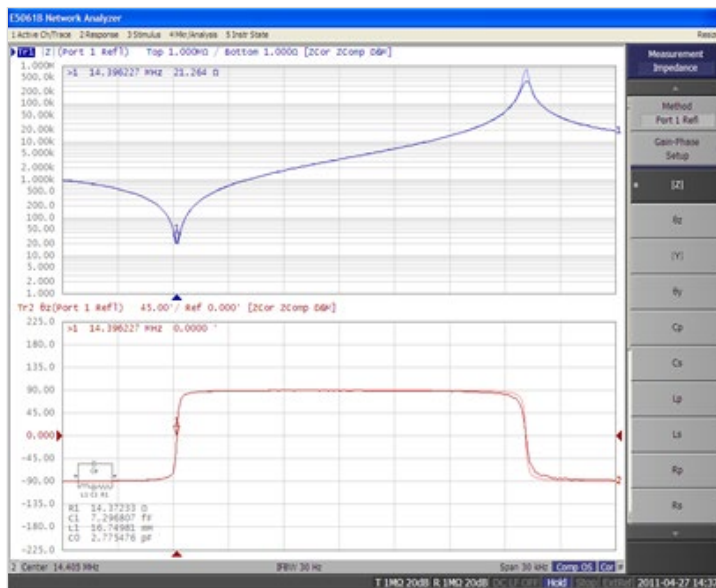

**Figure 18.** Although this measurement of a high-Q crystal resonator has the expected characteristics, adjusting the measurement settings will improve the computed equivalent circuit values.

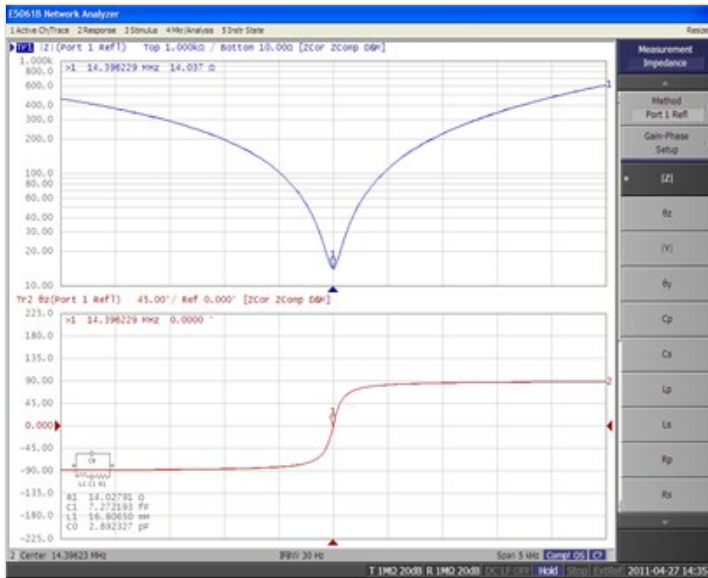

**Figure 19.** Using a narrower frequency span around the resonance provides a correct value for  $C_1$

## Adding a DC bias

To evaluate components under their expected operating conditions, it may be necessary to apply a bias voltage or current and then measure the impedance. Figure 20 shows a set of measurements from a 100 nF ceramic capacitor that has a strong dependency on the applied DC voltage. These were performed using the gain-phase series-through method and the DC bias was applied using the E5061B's internal DC source.

The upper trace shows the swept-frequency measurements performed using channel 1:  $|Z|$ , phase,  $C_s$  and  $R_s$ . The lower trace shows the results of a DC-bias sweep from  $-10$  to  $+10$  volts DC; a 10 kHz continuous-wave signal was also applied. In this case capacitance ranged from 70 nF at  $\pm 10$  V, 94 nF at 0 V, and 104 nF at  $\pm 2.5$  V.

Similarly, you can use an external power supply to inject a large DC current to bias power inductors and ferrite beads. This also requires use of a DC current bias adapter such as the Keysight 16200B and an external DC source to apply DC current through the adapter to the DUT.

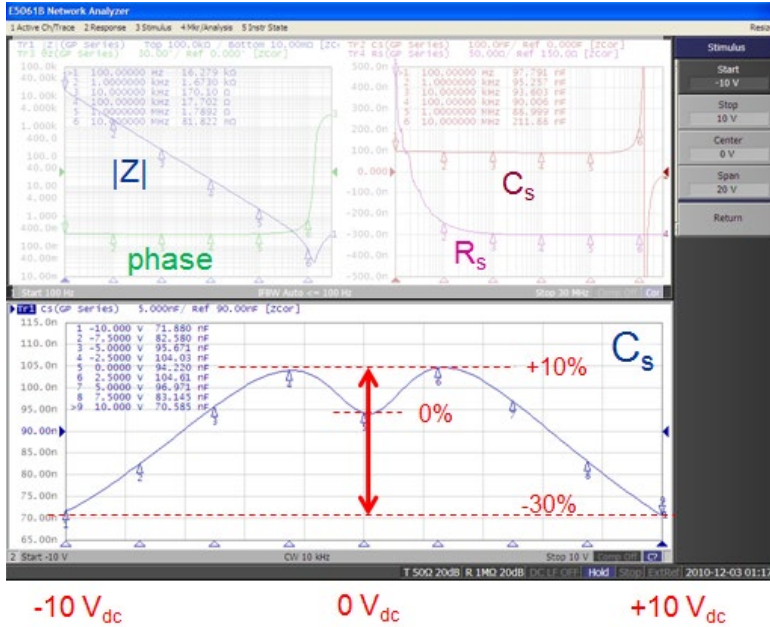

Figure 20. Sweeping the DC bias voltage provides a clear picture of capacitance varying with voltage changes.

## Adding an AC bias

The characterization of high-power components such as ultrasound resonators, ceramic actuators and power inductors often requires the addition of an AC bias. With the E5061B, it is necessary to increase the analyzer's source output level using an external power amplifier. This requires use of the gain-phase test port, the series-through method, and the 1 MΩ input impedance of the transmission and reflection inputs.

As shown in Figure 21, it is also necessary to add two user-created voltage-divider circuits to reduce the AC levels at the inputs (maximum input level is 1.78 V<sub>peak</sub> with 20 dB attenuation). Finally, an external high-power resistor (1 to 10 Ω) is also needed: R<sub>c</sub> is used to detect the AC current flowing through the DUT. The recommended calibration method is open/short/load; however, it is necessary to reduce the power amplifier output to a level the 50 Ω load can tolerate.

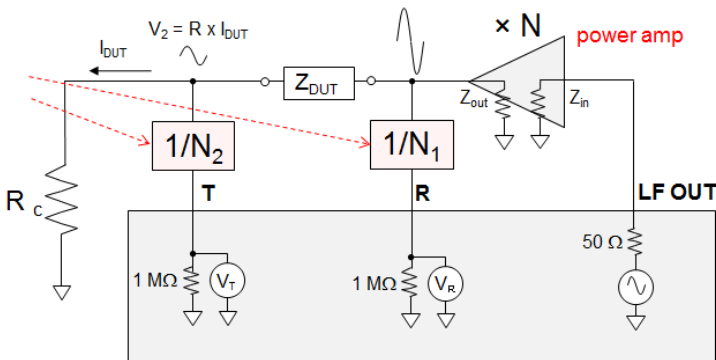
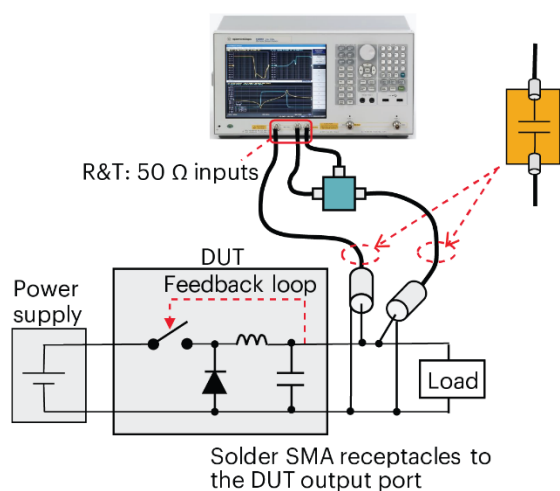

Figure 21. Surrounding the DUT with the external elements shown here makes it possible to measure a variety of high-power components.

## Measuring in-circuit impedance

A variety of applications require in-circuit measurements of impedance: printed RFID antennas, negative-impedance oscillator circuits and power integrity are just a few examples. When working in the megahertz range (e.g., RFID) hand probing may be used, and the reflection method is recommended. An example probe would consist of a semi-flexible SMA cable with a non-metal coating and the head of the Keysight 42941A impedance probe.

Characterization of a DC-to-DC converter works well with the gain-phase shunt-through method due to the combination of low impedance and low frequency (e.g., less than 10 MHz).<sup>1</sup> As shown in Figure 22, it is necessary to insert 1 mF capacitors to block DC voltages when the DUT output voltage exceeds 5 V.



**Figure 22.** This configuration enables accurate measurements of the output impedance of a DC-DC converter in its “on” and “off” states.

## Conclusion

When the E5061B is equipped to provide NA and ZA capabilities, it puts greater versatility on your R&D bench. Although E5061B-005 cannot match the ultimate overall performance of a dedicated impedance analyzer, it does enable you to apply measurement methods, calibration techniques, and fixturing choices that provide comparably accurate impedance measurements.

Every Keysight VNA is the ultimate expression of our expertise in linear and nonlinear device characterization. To learn more, please visit [www.keysight.com/find/VNA](http://www.keysight.com/find/VNA).

<sup>1</sup> For more information, refer again to the Evaluating DC-to-DC Converters application note (5990-5902EN).